



**NOTICE INVITING TENDER**

**FOR**

**ELECTRICAL WORKS (SUPPLY & ERECTION)**

**FOR**

**ALTERNATE POWER SUPPLY ARRANGEMENT OF**  
**VIKARMPUR GUEST HOUSE**

**TALCHER FERTILIZERS LTD.,**  
**ANGUL, ODISHA**



**NIT NO. : PNPM/PC-183/E/8001/NCB**

**PREPARED AND ISSUED BY**



**PROJECTS & DEVELOPMENT INDIA LTD.**  
**(A Govt. of India Enterprise)**  
**PDIL BHAWAN, A-14, Sector-1,**  
**NOIDA-201301, U.P., India**

*May, 2021*

	<b>ELECTRICAL WORKS (SUPPLY &amp; ERECTION) FOR ALTERNATE POWER SUPPLY ARRANGEMENT OF VIKARMPUR GUEST HOUSE TALCHER FERTILISER LIMITED, TALCHER</b>  <b>MASTER INDEX</b>	PC-183/E/8001/MI	0	
		DOC. NO.	REV.	
		Page 1 of 1		

## MASTER INDEX

**NIT NO. : PNP/PC-183/E/8001/NCB**

**NIT DESCRIPTION : TENDER DOCUMENT ELECTRICAL WORKS (SUPPLY & ERECTION) FOR ALTERNATE POWER SUPPLY ARRANGEMENT OF VIKARMPUR GUEST HOUSE AT TALCHER FERTILIZERS LTD., ANGUL, ODISHA**

Section-I	Invitation for Bid [IFB]
Section-II	BID EVALUATION CRITERIA [BEC] & Evaluation methodology
Section-III	Instructions to Bidders [ITB] Annexure(s) Forms & Formats
Section-IV	General Conditions of Contract [GCC]
Section-V	Special Conditions of Contract [SCC]
Section-VI	Specifications, Scope of Work and Drawing
Section-VII	Schedule of Rates



 पी डी आई एल <b>PDIL</b>	<b>PROJECTS &amp; DEVELOPMENT INDIA LIMITED</b>	PC-183/E/ 8001 /S-I	0	 <b>Talcher Fertilizers</b>
		DOC. NO.	REV.	
		Page - 1 - of 115		

**TENDER DOCUMENT  
FOR  
ELECTRICAL WORKS (SUPPLY & ERECTION)  
FOR  
ALTERNATE POWER SUPPLY ARRANGEMENT OF  
VIKARMPUR GUEST HOUSE  
AT  
TALCHER FERTILIZERS LTD., ANGUL, ODISHA**

**NIT NO.:PNPM/PC-183/E/8001/NCB**

**(OPEN DOMESTIC COMPETITIVE BIDDING)**

	<b>ELECTRICAL WORKS (SUPPLY &amp; ERECTION) FOR ALTERNATE POWER SUPPLY ARRANGEMENT OF VIKARMPUR GUEST HOUSE AT TALCHER FERTILIZERS LTD., ANGUL, ODISHA</b>	PC-183/E/ 8001 /S-I	0	
		DOC. NO.	REV.	
		Page - 2 - of 115		

**SECTION-I**

**INVITATION FOR BID (IFB)**

	<b>ELECTRICAL WORKS (SUPPLY &amp; ERECTION) FOR ALTERNATE POWER SUPPLY ARRANGEMENT OF VIKARMPUR GUEST HOUSE AT TALCHER FERTILIZERS LTD., ANGUL, ODISHA</b>	PC-183/E/ 8001 /S-I	0	
		DOC. NO.	REV.	
		Page - 3 - of 115		

**SECTION-I**

**"INVITATION FOR BID (IFB)"**

Ref No: \_\_\_\_\_

Date: \_\_\_\_\_

To,

**PROSPECTIVE BIDDERS**

**SUB: TENDER DOCUMENT FOR \_\_\_\_\_**



**Dear Sir/Madam,**

1.0 Projects and Development India Limited (PDIL), hereinafter referred to as CONSULTANT on behalf of M/s Talcher Fertilizers Ltd. (TFL), hereinafter referred as OWNER, has the pleasure of inviting eligible bidders to submit Bid ONLINE through Central Public Procurement (CPP) Portal (<https://eprocure.gov.in>) in Single Stage Two Bid System, for the subject Project.

The entire set of Bidding documents is also placed on the website at TFL website (<http://tflonline.co.in>) and PDIL website ([www.pdilin.com](http://www.pdilin.com)),

2.0 The brief details of the tender are as under:

<b>(A)</b>	NAME OF WORK / BRIEF SCOPE OF WORK/JOB	ELECTRICAL WORKS (SUPPLY & ERECTION) FOR ALTERNATE POWER SUPPLY ARRANGEMENT OF VIKARMPUR GUEST HOUSE AT TALCHER FERTILIZERS LTD. ANGUL, ODISHA				
<b>(B)</b>	TENDER NO. & DATE	PNPM/PC-183/E/8001/NCB dated 27.05.2021				
<b>(C)</b>	TYPE OF BIDDING SYSTEM	<table border="1" style="width: 100%;"> <tr> <td style="text-align: center;">SINGLE BID SYSTEM</td> <td style="width: 50px;"></td> </tr> <tr> <td style="text-align: center;">TWO BID SYSTEM</td> <td style="text-align: center;">√</td> </tr> </table>	SINGLE BID SYSTEM		TWO BID SYSTEM	√
SINGLE BID SYSTEM						
TWO BID SYSTEM	√					
<b>(D)</b>	TYPE OF TENDER	<table border="1" style="width: 100%;"> <tr> <td style="text-align: center;">E-TENDER (CPP PORTAL)</td> <td style="text-align: center;">√</td> </tr> <tr> <td style="text-align: center;">MANUAL</td> <td></td> </tr> </table>	E-TENDER (CPP PORTAL)	√	MANUAL	
E-TENDER (CPP PORTAL)	√					
MANUAL						

	<b>ELECTRICAL WORKS (SUPPLY &amp; ERECTION) FOR ALTERNATE POWER SUPPLY ARRANGEMENT OF VIKARPUR GUEST HOUSE AT TALCHER FERTILIZERS LTD., ANGUL, ODISHA</b>	PC-183/E/ 8001 /S-I	0	
		DOC. NO.	REV.	
		Page - 4 - of 115		

<b>(E)</b>	COMPLETION PERIOD	03 (Three) Months from date of issuance of 'FAX OF ACCEPTANCE'				
<b>(F)</b>	BID VALIDITY	120 days from the date of Techno-commercial Bid opening				
<b>(G)</b>	BID SECURITY / EARNEST MONEY DEPOSIT (EMD)	<table border="1" style="width: 100%;"> <tr> <td style="text-align: center;">APPLICABLE</td> <td style="text-align: center;">✗</td> </tr> <tr> <td style="text-align: center;">NOT APPLICABLE</td> <td style="text-align: center;">✓</td> </tr> </table> <p>Wherever BID SECURITY/ EMD are appearing in the NIT, the same shall be read as "NOT APPLICABLE". In lieu of BID SECURITY/ EMD, bidder has to submit Declaration for Bid Security as per format (F-2)</p>	APPLICABLE	✗	NOT APPLICABLE	✓
APPLICABLE	✗					
NOT APPLICABLE	✓					
<b>(H)</b>	AVAILABILITY OF TENDER DOCUMENT ON WEBSITE(S)	<p>From 27.05.2021 (17:00 Hrs, IST) to 10.06.2021 (17:00 Hrs, IST) on following websites:</p> <p>(i) Govt. CPP Portal <a href="https://eprocure.gov.in">https://eprocure.gov.in</a>  (ii) TFL Website - <a href="http://tflonline.co.in">http://tflonline.co.in</a>  (iii) PDIL website - <a href="http://www.pdil.in">www.pdil.in</a></p>				
<b>(I)</b>	DATE, TIME & VENUE OF PRE-BID MEETING	Not Applicable				
<b>(J)</b>	START OF BID SUBMISSION ON CPP PORTAL	04.06.2021 at 15:00 Hrs. (IST)				
<b>(K)</b>	DUE DATE & TIME OF BID-SUBMISSION	Date : 10.06.2021 Time : 17:00 Hrs (IST)				
<b>(L)</b>	DATE AND TIME OF UN-PRICED BID OPENING (IN PRESENCE OF AUTHORIZED REPRESENTATIVE OF BIDDERS)	Date: 11.06.2021 Time :17:00 hrs (IST) Onwards Venue: M/s Projects & Development India Limited, (Project Management Department) P.D.I.L Bhawan, A-14, Sector-1, Noida, (PIN 201301) Dist. Gautam Budh Nagar (UP). (India)				
<b>(M)</b>	ADDRESS FOR COMMUNICATION WITH PDIL	Projects & Development India Limited, (Project Management Department) P.D.I.L Bhawan, A-14, Sector-1, Noida , (India) Fax no.:0120-2529801				

	<b>ELECTRICAL WORKS (SUPPLY &amp; ERECTION) FOR ALTERNATE POWER SUPPLY ARRANGEMENT OF VIKARMPUR GUEST HOUSE AT TALCHER FERTILIZERS LTD., ANGUL, ODISHA</b>	PC-183/E/ 8001 /S-I	0	
		DOC. NO.	REV.	
		Page - 5 - of 115		

		Kind Attention: Mr. Kailash Joshi Project Manager Tel no. : +91-120-2529842/43/47/51/53/54 Extn. 314 Mob. No. : 9718762091 Fax no. : +91-120-2529801 E-mail : <a href="mailto:kjoshi@pdilin.com">kjoshi@pdilin.com</a>				
	ADDRESS FOR COMMUNICATION WITH OWNER (TFL) AT PROJECT OFFICE	GAIL INDIA LIMITED, PLOT NO. 24, FILM CITY, SECTOR 16A, NOIDA- 201301  Kind Attention : Mr. Avijit Jharimunya  E-mail : <a href="mailto:ajhari@gail.co.in">ajhari@gail.co.in</a>				
(O)	ADDRESS FOR COMMUNICATION WITH OWNER (TFL) AT SITE FOR SITE VISIT	Mr. Panchanan Halder-GM (P & E) Mob No. :8360677410 E-mail : <a href="mailto:phaldar@gail.co.in">phaldar@gail.co.in</a>				
(P)	Reverse Auction	<table border="1" style="width: 100%;"> <tr> <td style="text-align: center;">APPLICABLE</td> <td></td> </tr> <tr> <td style="text-align: center;">NOT APPLICABLE</td> <td style="text-align: center;">√</td> </tr> </table> <p style="text-align: center;">(Also refer Clause No. 52 of ITB)</p>	APPLICABLE		NOT APPLICABLE	√
APPLICABLE						
NOT APPLICABLE	√					

In case the days specified above happens to be a holiday in TFL/PDIL, the next working day shall be implied.

- 3.0 Bids must be submitted strictly in accordance with Clause No. 11 of ITB depending upon Type of Tender as mentioned at Clause no. 2.0 (D) of IFB. The IFB is an integral and inseparable part of the bidding document.
- 4.0 The following documents in addition to uploading in the bid on CPP portal shall also be submitted in Original (in physical form) within 7 (seven) days from the bid due date provided the scanned copies of the same have been uploaded in along with e-bid within the due date and time to the address mentioned in Bidding Data Sheet(BDS):-
- i) Bid Security Declaration
  - ii) Power of Attorney
  - iii) Integrity Pact

However, in view of COVID 19 situation, few relaxations are permitted to facilitate the processing of tender during period of restricted movement due to COVID outbreak, Details of relaxation is attached as Annexure-VII

- 5.0 Bidder(s) are advised to quote strictly as per terms and conditions of the tender documents and not to stipulate any deviations/exceptions.

	<b>ELECTRICAL WORKS (SUPPLY &amp; ERECTION) FOR ALTERNATE POWER SUPPLY ARRANGEMENT OF VIKARMPUR GUEST HOUSE AT TALCHER FERTILIZERS LTD., ANGUL, ODISHA</b>	PC-183/E/ 8001 /S-I	0	
		DOC. NO.	REV.	
		Page - 6 - of 115		

- 6.0 Any bidder, who meets the Bid Evaluation Criteria (BEC) and wishes to quote against this Tender Document, may download the complete Tender Document alongwith its amendment(s) if any from websites as mentioned at 2.0 (H) of IFB and submit their Bid complete in all respect as per terms & conditions of Tender Document on or before the Due Date & Time of Bid Submission.
- 7.0 Bid(s) received from bidders to whom tender/information regarding this Tender Document has been issued as well as offers received from the bidder(s) by downloading Tender Document from above mentioned website(s) shall be taken into consideration for evaluation & award provided that the Bidder is found responsive subject to provisions contained in Clause No. 2 of ITB.
- The Tender Document calls for offers on single point "Sole Bidder" responsibility basis (except where JV/Consortium bid is allowed pursuant to clause no. 3.0 of ITB) and in total compliance of Scope of Works as specified in Tender Document.
- 8.0 Amendments/Clarification(s)/Corrigendum(s) if any shall also be available on above referred websites. Any revision, Amendment, clarification, addendum, corrigendum, time extension, etc. to this Tender Document will be hosted on the abovementioned website(s) only. Bidders are requested to visit the website regularly to keep themselves updated.
- 9.0 All the bidders including those who are not willing to submit their bid are required to submit F-6(Acknowledgement cum Consent letter) duly filled within 7 days from receipt of tender information.
- 10.0 The bidder shall submit the bid ONLINE through Central Public Procurement (CPP) Portal. Bids complete in all respects should be uploaded in the CPP portal on or before the Bid Due Date and time mentioned in at SI No. 2(K) above. Bids through Post/ Fax / E-mail /CD/ any other mode other than that specified in ITB will not be accepted.
- 11.0 TFL/PDIL reserves the right to reject any or all the bids received at its discretion without assigning any reason whatsoever.

This is not an Order.

For & on behalf of  
(Projects & Development India Limited)



Kailash Joshi  
Project Manager  
E-mail ID : kjoshi@pdilin.com  
Contact No. :0120-2529842/ Ext. 314





 <p>पी डी आई एल <b>PDIL</b></p>	<p><b>ELECTRICAL WORKS (SUPPLY &amp; ERECTION) FOR ALTERNATE POWER SUPPLY ARRANGEMENT OF VIKARMPUR GUEST HOUSE AT TALCHER FERTILIZERS LTD., ANGUL, ODISHA</b></p>	PC-183/E/ 8001 /S-I	0	 <p><b>Talcher Fertilizers</b></p>
		DOC. NO.	REV.	
		Page - 7 - of 115		

**INTENTIONALLY LEFT BLANK**

 <p>पी डी आई एल <b>PDIL</b></p>	<p><b>ELECTRICAL WORKS (SUPPLY &amp; ERECTION) FOR ALTERNATE POWER SUPPLY ARRANGEMENT OF VIKARMPUR GUEST HOUSE AT TALCHER FERTILIZERS LTD., ANGUL, ODISHA</b></p>	PC-183/E/ 801 /S-II	0	 <p><b>Talcher Fertilizers</b></p>
		DOC. NO.	REV.	
		Page - 8 - of 120		

## SECTION-II

### BID EVALUATION CRITERIA & EVALUATION METHODOLOGY

	<b>ELECTRICAL WORKS (SUPPLY &amp; ERECTION) FOR ALTERNATE POWER SUPPLY ARRANGEMENT OF VIKARMPUR GUEST HOUSE AT TALCHER FERTILIZERS LTD., ANGUL, ODISHA</b>	PC-183/E/8001 /S-II	0	
		DOC. NO.	REV.	
		Page - 9 - of 120		

## SECTION-II

### BID EVALUATION CRITERIA (BEC) & EVALUATION METHODOLOGY

**Bidder shall submit bid subject to meeting the Bid Evaluation Criteria as stated here. Evaluation of Technical and Commercial offers shall be carried out for only those Bidders who shall meet the Bid Evaluation Criteria.**

#### 1. Technical Criteria

- 1.1** The bidder must have completed at least one single order/ contract of value not less than Rs.37.76 Lakh (including taxes) for the job of Electrical Maintenance / Electrical Work / Electrical Construction / Electrical Supply & Erection /Electrical Erection during the last seven (07) years reckoned from the bid opening date.

To meet the Technical Criteria 1.1 above, only single contract is acceptable. In case bidder has executed and completed composite works which includes any of the qualifying works(s) stated above, then value of such qualifying works out of the total value of composite works shall be considered for the purpose of qualification

- 1.2** The bidder must have valid 'A' Class Electrical Contractors License or equivalent to 'A' Class Electrical License issued from any State Government Agency/Authority.

#### Notes for 1.1 above

- a. In case more than one contract/order/agreement/DLOA are emanating against same tender, these contracts are to be considered as single contract for evaluation of credentials of a bidder for meeting their experience criteria.
- b. Job executed by a Bidder for its own plant/ project cannot be considered as experience for the purpose of meeting BEC of the tender. However, jobs executed for Subsidiary/ Fellow subsidiary/ Holding company will be considered as experience for the purpose of meeting BEC subject to submission of tax paid invoice(s) duly certified by Statutory Auditor of the Bidder towards payments of statutory tax in support of the job executed for Subsidiary/ Fellow subsidiary/ Holding company. Such Bidders to submit these documents in addition to the documents specified to meet BEC.
- c. The bidder must submit the completion certificate/acceptance certificate issued by end user/ owner (or their consultant who has been duly authorized by them to issue such certificate) only after completion of work/ supply in all aspects.
- d. Only documents (Work order, completion certificate, execution certificate etc.) which have been referred /specified in the bid shall be considered in reply to the queries during evaluation of bids.
- e. Experience of bidder acquired as a subcontractor can be accepted against submission of certificate from end user by such bidder along with other specified documents.
- f. Bids from Consortium / Joint Venture shall not be accepted.

	<b>ELECTRICAL WORKS (SUPPLY &amp; ERECTION) FOR ALTERNATE POWER SUPPLY ARRANGEMENT OF VIKARMPUR GUEST HOUSE AT TALCHER FERTILIZERS LTD., ANGUL, ODISHA</b>	PC-183/E/8001 /S-II	0	
		DOC. NO.	REV.	
		Page - 10 - of 120		

### 1.3 Applicability of Policy for providing preference to Domestically manufactured Iron & Steel products

#### Clause 1.2 not applicable for this Tender

Bidder should have minimum prescribed domestic value addition requirement in line with the Domestic Manufactured iron & Steel Policy (DMI & SP) for the Iron & Steel products involved in execution of the contract. Bidder shall submit affidavit from the domestic manufacturers of such Iron & steel products as per the **Form F-18** enclosed.

A bidder who is not manufacturer of Iron & Steel product and is unable to submit the Affidavit from domestic manufacturers at bidding stage, such bidder can submit the Affidavit issued by domestic manufacturers after placement of order. In this case bidder along with his bid shall submit an undertaking as per attached format (**Annexure - V to IFB**).

If a bidder does not submit above affidavit/ undertaking as per format, the offer of bidder shall be rejected.

## 2. Financial Criteria

- 2.1 Annual financial turnover of the bidder in any of the last three (03) preceding financial years of the bidders should be at least **INR 37.76 Lakh**.
- 2.2 Net Worth of the bidder should be positive as per last audited financial year.
- 2.3 Bidder should have minimum working capital equal to **Rs.7.55 Lakh** as per last audited financial year. However, if the bidder's working capital is negative or inadequate, the bidder shall submit a letter from their Bank having Net worth of the bank not less than Rs. 100.0 Corers (or equivalent in **USD**, confirming the availability of line of credit for **Rs. 7.55 Lakh**. The line of credit from bank shall be submitted strictly as per prescribed format.

#### Note for 2 [(2.1, (2.2) and (2,.3)]

**Annual Turnover:** In case of tenders having due date for submission of bid up to **30th September** of the relevant financial year, and if audited financial results of the immediate three (3) preceding financial years are not available, the bidder has an option to submit the audited financial results of the 3 years immediately prior to that. Wherever the closing date of the bid is after 30th September of the relevant financial year, bidder has to compulsorily submit the audited financial results for the immediate three (3) preceding financial years

**Net Worth & Working Capital:** In case of tenders having due date for submission of bid upto **30th September** of the relevant financial year, and if audited financial results of the immediate preceding financial year is not available, in such case, the audited



	<b>ELECTRICAL WORKS (SUPPLY &amp; ERECTION) FOR ALTERNATE POWER SUPPLY ARRANGEMENT OF VIKARMPUR GUEST HOUSE AT TALCHER FERTILIZERS LTD., ANGUL, ODISHA</b>	PC-183/E/8001 /S-II	0	
		DOC. NO.	REV.	
		Page - 11 - of 120		

financial results of the year immediately prior to that year will be considered as last financial year for Net worth & Working Capital calculation. Wherever the closing date of the bid is after 30th September of the relevant financial year, Bidder has to compulsorily submit the audited financial results for the immediate preceding financial year.

### 3. **BEC for START-UPS:**

Prior experience and Prior turnover criteria as mentioned in Clause No. 1.1 & 2.1 above shall not be applicable for start-ups[whether Micro & Small Enterprises (MSEs) or otherwise] subject to their meeting the quality and technical specifications specified in tender document. However, the start-ups have to meet BEC as mentioned in Clause No. 1.2, 2.2 & 2.3 on their own.

For availing the relaxation, bidder is required to submit requisite certificate towards Startup enterprise registration issued by Department for Promotion of Industry and Internal Trade (DPIIT), Ministry of Commerce & Industry specifying the goods/ job domain wherein they are registered for. In case the certificate of DPIIT towards recognition does not specify the goods/ job domain, startups are required to submit the documents for the same including the application submitted to DPIIT. Further, above document should also be certified by the Chartered Accountant (not being an employee or a Director or not having any interest in the bidder's company/firm) and notary public with legible stamp.

	<b>ELECTRICAL WORKS (SUPPLY &amp; ERECTION) FOR ALTERNATE POWER SUPPLY ARRANGEMENT OF VIKARMPUR GUEST HOUSE AT TALCHER FERTILIZERS LTD., ANGUL, ODISHA</b>	PC-183/E/8001 /S-II	0	
		DOC. NO.	REV.	
		Page - 12 - of 120		

#### 4. Documents to be submitted for Compliance to BEC

##### (i) Technical Criteria of BEC:

- (a) To meet the criteria as mentioned above at Sl. No. 1.1, the bidder must submit Copy of Detailed Letter of Acceptance (DLOA) / Contract Agreement / Work Order clearly specifying scope of work/ relevant Extract of Work Order such as BOQ/SOR ,Scope of work and Completion/ Acceptance Certificate issued by end user/ owner (or their consultant who has been duly authorized by them to issue such certificate)

The Detailed Letter of Acceptance (DLOA) / Contract Agreement / Work Order must clearly indicate nature of Work, completion / contract period and contract value. Similarly, The Completion/Acceptance Certificate shall clearly indicate the LOA / Work Order /Agreement no., Name of Work, Contract Value, Completed value, Completion period and actual Date of Completion.

- (b) To meet criteria as mentioned above at Sr. No. 1.2 above, Bidder must submit copy of valid 'A' Class Electrical Contractors License or equivalent to 'A' Class Electrical License issued by any 'State Government Agency/Authority'.
- (c) ~~To meet the criteria as mentioned above at Sl. No. 1.2, Affidavit (in original duly notarized) for Domestically Manufactured Iron & Steel Policy as per Form F-18/ Undertaking from bidder as per Annexure A.~~

##### (ii) Financial Criteria of BEC:

- (a) To meet the criteria mentioned at Sl. No. 2.1 above, bidder shall submit Audited Annual Financial Statements of the company for any one of the preceding three (03) financial years whichever meets the annual turnover criteria .
- (b) To meet the criteria mentioned at Sl. No. 2.2 above, bidder shall submit Audited Annual Financial Statements for immediately preceding financial year alongwith "Details of Financial Capability of the Bidder" in prescribed format duly signed and stamped by Chartered Accountant.
- (c) To meet the criteria for Sr. No. 2.3, Bidder shall submit the last Audited Financial Statements alongwith (i) Bank's Letter (if applicable) and (ii) "Details of Financial Capability of the Bidder" in prescribed format duly signed and stamped by Chartered Accountant..
- (d) If the bidder's working capital is negative or inadequate, the bidder shall submit a letter from their bank having net worth not less than Rs.100 Crores (or equivalent USD), confirming the availability of line of credit for working capital amount mentioned herein above. The line of credit letter from bank to be submitted strictly as per prescribed format.

	<b>ELECTRICAL WORKS (SUPPLY &amp; ERECTION) FOR ALTERNATE POWER SUPPLY ARRANGEMENT OF VIKARMPUR GUEST HOUSE AT TALCHER FERTILIZERS LTD., ANGUL, ODISHA</b>	PC-183/E/8001 /S-II	0	
		DOC. NO.	REV.	
		Page - 13 - of 120		

For 4.0 (ii) above, the "Note for 2[(2.1), (2.2) and (2.3) under 2.0 (Financial Criteria of BEC) shall apply.

**5. Authentication of all documents submitted against BEC**

- 5.1 All documents in support of Sl. No. 1.1 of Technical Criteria of BEC to be furnished by the Bidder shall necessarily be duly certified/ attested by Chartered Engineer and Notary Public with legible stamp.
- 5.2 For authentication of document submitted in support of Financial Criteria of Bid Evaluation criteria (BEC), copy of audited annual financial statements submitted with bid shall be duly certified/ attested by Notary Public with legible stamp.

Further, bidder shall submit "Details of financial capability of Bidder" in prescribed format duly signed and stamped by a Chartered Accountant/ Certified Public Accountant (CPA).

**6. Evaluation Methodology:**

The subject work is indivisible and complete work shall be awarded to successful overall lowest bidder as per evaluation methodology described below. In other words, evaluation of bids shall be done on overall L-1 basis considering all applicable taxes & duties including GST as under:

- (i) Total quoted price as per SOR (Section-VII) inclusive of all taxes & duties including GST after arithmetic correction of errors (if any).
- (ii) In case any cess on GST is applicable, same shall also be considered in evaluation.
- (iii) In case any unregistered bidder is submitting their bid, their prices will be loaded with applicable GST (CGST & SGST/UTGST or IGST) while evaluation of bid (if applicable as per Govt. Act/Law in vogue).

Correction of error, if any shall be done as per clause no. 30.0 of ITB.

 <p>पी डी आई एल <b>PDIL</b></p>	<p><b>ELECTRICAL WORKS (SUPPLY &amp; ERECTION) FOR ALTERNATE POWER SUPPLY ARRANGEMENT OF VIKARMPUR GUEST HOUSE AT TALCHER FERTILIZERS LTD., ANGUL, ODISHA</b></p>	PC-183/E/8001 /S-II	0	 <p><b>Talcher Fertilizers</b></p>
		DOC. NO.	REV.	
		Page - 14 - of 120		

**INTENTIONALLY LEFT BLANK**



	<b>ELECTRICAL WORKS (SUPPLY &amp; ERECTION) FOR ALTERNATE POWER SUPPLY ARRANGEMENT OF VIKARMPUR GUEST HOUSE AT TALCHER FERTILIZERS LTD., ANGUL, ODISHA</b>	PC-183/E/ 8001 /S-III	0	
		DOC. NO.	REV .	
		Page - 15 - of 120		

### SECTION-III

**INSTRUCTION TO BIDDERS**  
[TO BE READ IN CONJUNCTION WITH BIDDING DATA SHEET (BDS)]

	<b>ELECTRICAL WORKS (SUPPLY &amp; ERECTION) FOR ALTERNATE POWER SUPPLY ARRANGEMENT OF VIKARMPUR GUEST HOUSE AT TALCHER FERTILIZERS LTD., ANGUL, ODISHA</b>	PC-183/E/ 8001 /S-III	0	
		DOC. NO.	REV	
		Page - 16 - of 120		

### SECTION-III

#### INSTRUCTION TO BIDDERS

##### INDEX

- [A] GENERAL:**
1. SCOPE OF BID
  2. ELIGIBLE BIDDERS
  3. BIDS FROM CONSORTIUM / JOINT VENTURE
  4. ONE BID PER BIDDER
  5. COST OF BIDDING
  6. SITE-VISIT
- [B] BIDDING DOCUMENTS:**
7. CONTENTS OF BIDDING DOCUMENTS
  8. CLARIFICATION OF BIDDING DOCUMENTS
  9. AMENDMENT OF BIDDING DOCUMENTS
- [C] PREPARATION OF BIDS:**
10. LANGUAGE OF BID
  11. DOCUMENTS COMPRISING THE BID
  12. SCHEDULE OF RATES / BID PRICES
  13. GST (CGST & SGST/ UTGST or IGST )
  14. BID CURRENCIES
  15. BID VALIDITY
  16. EARNEST MONEY DEPOSIT
  17. PRE-BID MEETING
  18. FORMAT AND SIGNING OF BID
  19. ZERO DEVIATION & REJECTION CRITERIA
  20. PAYMENT
- [D] SUBMISSION OF BIDS:**
21. SUBMISSION, SEALING AND MARKING OF BIDS
  22. DEADLINE FOR SUBMISSION OF BIDS
  23. LATE BIDS
  24. MODIFICATION AND WITHDRAWAL OF BIDS
  25. EMPLOYER'S RIGHT TO ACCEPT ANY BID AND TO REJECT ANY OR ALL BIDS
- [E] BID OPENING AND EVALUATION:**
26. BID OPENING
  27. CONFIDENTIALITY
  28. CONTACTING THE EMPLOYER
  29. EXAMINATION OF BIDS AND DETERMINATION OF RESPONSIVENESS
  30. CORRECTION OF ERRORS
  31. CONVERSION TO SINGLE CURRENCY FOR COMPARISON OF BIDS
  32. EVALUATION AND COMPARISON OF BIDS
  33. COMPENSATION FOR EXTENDED STAY
  34. PURCHASE PREFERENCE

	<b>ELECTRICAL WORKS (SUPPLY &amp; ERECTION) FOR ALTERNATE POWER SUPPLY ARRANGEMENT OF VIKARMPUR GUEST HOUSE AT TALCHER FERTILIZERS LTD., ANGUL, ODISHA</b>	PC-183/E/ 8001 /S-III	0	
		DOC. NO.	REV	
		Page - 17 - of 120		

**[F] AWARD OF CONTRACT:**

35. AWARD
36. NOTIFICATION OF AWARD / FAX OF ACCEPTANCE [FOA]
37. SIGNING OF AGREEMENT
38. CONTRACT PERFORMANCE SECURITY / SECURITY DEPOSIT
39. PROCEDURE FOR ACTION IN CASE CORRUPT/FRAUDULENT/COLLUSIVE/COERCIVE PRACTICES
40. PUBLIC PROCUREMENT POLICY FOR MICRO AND SMALL ENTERPRISES
41. AHR ITEMS
42. VENDOR PERFORMANCE EVALUATION
43. INCOME TAX & CORPORATE TAX
44. SETTLEMENT OF DISPUTES BETWEEN GOVERNMENT DEPARTMENT AND ANOTHER AND ONE GOVERNMENT DEPARTMENT AND PUBLIC ENTERPRISE AND ONE PUBLIC ENTERPRISE AND ANOTHER
45. DISPUTE RESOLUTION MECHANISM
46. INAM-PRO (PLATFORM FOR INFRASTRUCTURE AND MATERIALS PROVIDERS)
47. PROMOTION OF PAYMENT THROUGH CARDS AND DIGITAL MEANS
48. CONTRACTOR TO ENGAGE CONTRACT MANPOWER BELONGING TO SCHEDULED CASTES AND WEAKER SECTIONS OF THE SOCIETY
49. QUARTERLY CLOSURE OF THE CONTRACT
50. PROVISION FOR STARTUPS
51. PROVISION REGARDING INVOICE FOR REDUCED VALUE OR CREDIT NOTE TOWARDS PRS
52. PROVISION REGARDING REVERSE AUCTION
53. UNIQUE DOCUMENT IDENTIFICATION NUMBER BY PRACTICING CHARTERED ACCOUNTANTS
54. CLAUSE REGARDING PROVISION FOR PROCUREMENT FROM A BIDDER WHICH SHARES A LAND BORDER WITH INDIA

**[G] ANNEXURES:**

1. ANNEXURE-I: PROCEDURE FOR ACTION IN CASE CORRUPT/FRAUDULENT/COLLUSIVE/COERCIVE PRACTICES
2. ANNEXURE-II: VENDOR PERFORMANCE EVALUATION PROCEDURE
3. ANNEXURE-III : ADDENDUM TO INSTRUCTIONS TO BIDDERS (INSTRUCTION FOR PARTICIPATION IN E-TENDER)
4. ANNEXURE-IV: BIDDING DATA SHEET (BDS)
5. ANNEXURE-V: POLICY TO PROVIDE PURCHASE PREFERENCE (LINKED WITH LOCAL CONTENT)
6. ANNEXURE-VI: FORMS AND FORMATS

	<b>ELECTRICAL WORKS (SUPPLY &amp; ERECTION) FOR ALTERNATE POWER SUPPLY ARRANGEMENT OF VIKARMPUR GUEST HOUSE AT TALCHER FERTILIZERS LTD., ANGUL, ODISHA</b>	PC-183/E/ 8001 /S-III	0	
		DOC. NO.	REV	
		Page - 18 - of 120		

**INSTRUCTIONS TO BIDDERS [ITB]**  
**[TO BE READ IN CONJUNCTION WITH BIDDING DATA SHEET (BDS)]**

**[A] – GENERAL**

**1 SCOPE OF BID**

- 1.1 The Employer as defined in the "General Conditions of Contract [GCC]", wishes to receive Bids as described in the Bidding Document/Tender document issued by Employer. Employer/Owner/TFL occurring herein under shall be considered synonymous.
- 1.2 SCOPE OF BID: The scope of work/ Services shall be as defined in the Bidding documents.
- 1.3 The successful bidder will be expected to complete the scope of Bid within the period stated in Special Conditions of Contract.
- 1.4 Throughout the Bidding Documents, the terms 'Bid', 'Tender' & 'Offer' and their derivatives [Bidder/Tenderer, Bid/Tender/Offer etc.] are synonymous. Further, 'Day' means 'Calendar Day' and 'Singular' also means 'Plural'.

**2 ELIGIBLE BIDDERS**

- 2.1 The Bidder shall not be under a declaration of ineligibility by Employer for Corrupt/ Fraudulent/ Collusive/ Coercive practices, as defined in "Instructions to Bidders [ITB], Clause No. 39" (Action in case Corrupt/ Fraudulent/ Collusive/ Coercive Practices).
- 2.2 The Bidder is not put on 'Holiday' by any of the JV partners of OWNER (viz. GAIL, RCF, CIL) or Public Sector Project Management Consultant (like PDIL, EIL, Mecon only due to "poor performance" or "corrupt and fraudulent practices") or banned/blacklisted by Government department/ Public Sector on due date of submission of bid.

If the bidding documents were issued inadvertently/ downloaded from website, offers submitted by such bidders shall not be considered for opening/ evaluation/Award and will be returned immediately to such bidders.

In case there is any change in status of the declaration prior to award of contract, the same has to be promptly informed to TFL/PDIL by the bidder.

It shall be the sole responsibility of the bidder to inform TFL/PDIL in case the bidder is put on 'Holiday' by JV partners of OWNER (viz. GAIL, RCF, CIL) or Public Sector Project Management Consultant (like PDIL, EIL, Mecon. only due to "poor performance" or "corrupt and fraudulent practices") or banned/blacklisted by Government department/ Public Sector on due date of submission of bid and during the course of finalization of the tender. Concealment of the facts shall tantamount to misrepresentation of facts and shall lead to action against such Bidders as per clause 39 of ITB.

- 2.3 The Bidder should not be under any liquidation court receivership or similar proceedings on due date of submission of bid.

	<b>ELECTRICAL WORKS (SUPPLY &amp; ERECTION) FOR ALTERNATE POWER SUPPLY ARRANGEMENT OF VIKARMPUR GUEST HOUSE AT TALCHER FERTILIZERS LTD., ANGUL, ODISHA</b>	PC-183/E/ 8001 /S-III	0	
		DOC. NO.	REV	
		Page 19 of 115		

In case there is any change in status of the declaration prior to award of contract, the same has to be promptly informed to TFL/PDIL by the bidder.

It shall be the sole responsibility of the bidder to inform TFL/PDIL in case the bidder is under any liquidation court receivership or similar proceedings on due date of submission of bid and during the course of finalization of the tender. Concealment of the facts shall tantamount to misrepresentation of facts and shall lead to action against such Bidders as per clause no.39 of ITB.

2.4 Bidder shall not be affiliated with a firm or entity:

- (i) that has provided consulting services related to the work to the Employer during the preparatory stages of the work or of the project of which the works/services forms a part of or
- (ii) That has been hired (or proposed to be hired) by the Employer as an Engineer/ Consultant for the contract.

2.5 Neither the firm/entity appointed as the Project Management Consultant (PMC) for a contract nor its affiliates/ JV'S/ Subsidiaries shall be allowed to participate in the tendering process unless it is the sole Licensor/Licensor nominated agent/ vendor.

2.6 Pursuant to qualification criteria set forth in the bidding document, the Bidder shall furnish all necessary supporting documentary evidence to establish Bidder's claim of meeting qualification criteria.

**2.7 Power of Attorney (POA):**

Power of Attorney to be issued by the bidder in favour of the authorized employee(s), in respect of the particular tender, for purpose of signing the documents including bid, all subsequent communications, agreements, documents etc. pertaining to the tender and act and take any and all decision on behalf of the bidder (including Consortium). Any consequence resulting due to such signing shall be binding on the Bidder (including Consortium).

In case of a single Bidder, the power of Attorney shall be issued **(as per format F-15)** as per the constitution of the bidder as below:

- a) **In case of Proprietorship:** By Proprietor
- b) **In case of Partnership:** by all Partners or Managing Partner.
- c) **In case of Limited Liability Partnership:** by any bidder's employee authorized in terms of Deed of LLP.
- d) **In case of Public /Limited Company:** POA in favour of authorized employee(s) by Board of Directors through Board Resolution or by the designated officer authorized by Board to do so. Such Board Resolution should be duly countersigned by Company Secretary / MD / CMD / CEO.

***The Power of Attorney should be valid till award of contract/order to successful bidder.***

	<b>ELECTRICAL WORKS (SUPPLY &amp; ERECTION) FOR ALTERNATE POWER SUPPLY ARRANGEMENT OF VIKARMPUR GUEST HOUSE AT TALCHER FERTILIZERS LTD., ANGUL, ODISHA</b>	PC-183/E/ 8001 /S-III	0	
		DOC. NO.	REV	
		Page 20 of 115		

**3 BIDS FROM "JOINT VENTURE"/"CONSORTIUM"**

Not applicable for this tender.

**4. ONE BID PER BIDDER**

4.1 Bidder shall submit only 'one [01] Bid' in the same Bidding Process either as single entity or as a member of any consortium (wherever consortium bid is allowed). A Bidder who submits or participates in more than 'one [01] Bid' will cause all the proposals in which the Bidder has participated to be disqualified.

4.2 More than one bid means bid(s) by bidder(s) having same Proprietor / Partners / Limited Liability Partner in any other Bidder(s). Further, more than one bids shall also include two or more bidders having common power of attorney holder.

Failure to comply this clause during tendering process will disqualify all such bidders from process of evaluation of bids.

4.3 Alternative Bids shall not be considered.

4.4 The provisions mentioned at Sl. no. 4.1 and 4.2 shall not be applicable wherein bidders are quoting for different Items / Sections / Parts / Groups/ SOR items of the same tender which specifies evaluation on Items / Sections / Parts / Groups/ SOR items basis.

Further, the Details of Partner(s) / Proprietor / Power of Attorney holders of bidder are to be necessarily sought in Format for 'Bidder's General Information' in the tender document.

**5. COST OF BIDDING**

The Bidder shall bear all costs associated with the preparation and submission of the Bid including but not limited to Bank charges all courier charges including taxes & duties etc. incurred thereof. Further, TFL/PDIL will in no case, be responsible or liable for these costs, regardless of the outcome of the bidding process.

**6. SITE VISIT**

6.1 The Bidder is advised to visit and examine the site of works and its surroundings and obtain for itself on its own responsibility all information that may be necessary for preparing the Bid and entering into a Contract for the required job. The costs of visiting the site shall be borne by the Bidder.

6.2 The Bidder or any of its personnel or agents shall be granted permission by the Employer to enter upon its premises and land for the purpose of such visits, but only upon the express conditions that the Bidder, its personnel and agents will release and indemnify the Employer and its personnel, agents from and against all liabilities in respect thereof, and will be responsible for death or injury, loss or damage to property, and any other loss, damage, costs, and expenses incurred as a result of inspection.

	<b>ELECTRICAL WORKS (SUPPLY &amp; ERECTION) FOR ALTERNATE POWER SUPPLY ARRANGEMENT OF VIKARMPUR GUEST HOUSE AT TALCHER FERTILIZERS LTD., ANGUL, ODISHA</b>	PC-183/E/ 8001 /S-III	0	
		DOC. NO.	REV	
		Page 21 of 115		

- 6.3 The Bidder shall not be entitled to hold any claim against TFL/PDIL for non-compliance due to lack of any kind of pre-requisite information as it is the sole responsibility of the Bidder to obtain all the necessary information with regard to site, surrounding, working conditions, weather etc. on its own before submission of the bid.

## **[B] – BIDDING DOCUMENTS**

### **7. CONTENTS OF BIDDING DOCUMENTS**

- 7.1 The contents of Bidding Documents / Tender Documents are those stated below, and should be read in conjunction with any 'Addendum / Corrigendum' issued in accordance with "ITB: Clause-9":

- Section-I : Invitation for Bid [IFB]
- Section-II : BID EVALUATION CRITERIA [BEC] & Evaluation methodology
- Section-III : Instructions to Bidders [ITB]  
Annexure  
Forms & Format
- Section-IV : General Conditions of Contract [GCC]
- Section-V : Special Conditions of Contract [SCC]
- Section-VI : Technical Specifications, Scope of Work and Drawings
- Section-VII : Schedule of Rates

\*Request for Quotation', wherever applicable, shall also form part of the Bidding Document.

- 7.2 The Bidder is expected to examine all instructions, forms, terms & conditions in the Bidding Documents. The "Request for Quotation [RFQ] & Invitation for Bid (IFB)" together with all its attachments thereto, shall be considered to be read, understood and accepted by the Bidders. Failure to furnish all information required by the Bidding Documents or submission of a Bid not substantially responsive to the Bidding Documents in every respect will be at Bidder's risk and may result in the rejection of his Bid.

### **8. CLARIFICATION OF BIDDING DOCUMENTS**

- 8.1 A prospective Bidder requiring any clarification(s) of the Bidding Documents may notify PDIL in writing or by fax or email at PDIL's mailing address indicated in the BDS no later than 02 (two) days prior to pre-bid meeting (in cases where pre-bid meeting is scheduled) or 05 (five) days prior to the due date of submission of bid in cases where pre-bid meeting is not held. TFL/PDIL reserves the right to ignore the bidders request for clarification if received after the aforesaid period. TFL/PDIL may respond in writing to the request for clarification. TFL/PDIL's response including an explanation of the query, but without identifying the source of the query will be uploaded on web sites as indicated at Sl. No. 2.0 (H) IFB / communicated to prospective bidders by e-mail/ fax.

	<b>ELECTRICAL WORKS (SUPPLY &amp; ERECTION) FOR ALTERNATE POWER SUPPLY ARRANGEMENT OF VIKARMPUR GUEST HOUSE AT TALCHER FERTILIZERS LTD., ANGUL, ODISHA</b>	PC-183/E/ 8001 /S-III	0	
		DOC. NO.	REV	
		Page 22 of 115		

8.2 Any clarification or information required by the Bidder but same not received by the Employer at clause 8.1 (refer BDS for address) above is liable to be considered as "no clarification / information required".

**9. AMENDMENT OF BIDDING DOCUMENTS**

9.1 At any time prior to the 'Bid Due Date', Owner may, for any reason, whether at its own initiative or in response to a clarification requested by a prospective Bidder, modify the Bidding Documents by addenda/ corrigendum.

9.2 Any addendum/ corrigendum thus issued shall be integral part of the Tender Document and shall be hosted on the websites as provided at clause no. 2.0 (H) of IFB. Bidders have to take into account all such addendum/ corrigendum before submitting their Bid.

9.3 The Employer, if consider necessary, may extend the date of submissions of Bid in order to allow the Bidders a reasonable time to furnish their most competitive bid taking into account the amendment issued thereof.

**[C] – PREPARATION OF BIDS**

**10. LANGUAGE OF BID:**

The bid prepared by the Bidder and all correspondence, drawing(s), document(s), certificate(s) etc. relating to the Bid exchanged by Bidder and PDIL shall be written in English language only. In case a document, certificate, printed literature etc. furnished by the Bidder in a language other than English, the same should be accompanied by an English translation duly authenticated by the Chamber of Commerce of Bidders Country, in which case, for the purpose of interpretation of the Bid, the English translation shall govern.

**11. DOCUMENTS COMPRISING THE BID**

11.1 In case the Bids are invited under the Manual two Bid system(**Not applicable for this Tender**):

The Bid prepared by the Bidder shall comprise the following components sealed in 2 different envelopes:

11.1.1 **ENVELOPE-I: "TECHNO-COMMERCIAL / UN-PRICED BID"** shall contain the following:

- (a) 'Covering Letter' on Bidder's 'Letterhead' clearly specifying the enclosed contents.
- (b) 'Bidder's General Information', as per 'Form F-1'.
- (c) 'Letter of Authority' on the Letter Head, as per 'Form F-3'
- (d) 'Agreed Terms and Conditions', as per 'Form F-5'
- (e) 'ACKNOWLEDGEMENT CUM CONSENT LETTER', as per 'Form F-6'
- (f) Duly attested documents in accordance with the "BID EVALUATION CRITERIA [BEC]" establishing the qualification as per SECTION II of tender document.



	<b>ELECTRICAL WORKS (SUPPLY &amp; ERECTION) FOR ALTERNATE POWER SUPPLY ARRANGEMENT OF VIKARMPUR GUEST HOUSE AT TALCHER FERTILIZERS LTD., ANGUL, ODISHA</b>	PC-183/E/ 8001 /S-III	0	
		DOC. NO.	REV	
		Page 23 of 115		

- (g) Power of Attorney as per Format F-15 /copy of Board Resolution, in favour of the authorized signatory of the Bid, as per clause no.2.7 of ITB
- (h) Bid security Declaration as per Form F-2
- (i) All forms and Formats including Annexures.
- (j) Copies of documents defining constitution of legal status of firm, place of registration and principal place of Business of the firm.
- (k) 'Integrity Pact' as per 'Form F-13'
- (l) 'Indemnity Bond' as per 'Form F-14'
- (m) Tender Document duly signed/ digitally signed by the Authorized Signatory (as applicable).
- (n) Copies of document related to ESI No., EPF No., GST No. and PAN No. of Company
- (o) Declaration by Bidder towards Minimum Local Content as per Form F-22.
- (p) Undertaking regarding provisions for procurement from a bidder which shares a land border with India as per Form F-20 and Form F-21.

**Note:**

1. All the pages of the Bid must be duly signed/ digitally signed by the "Authorized Signatory" of the Bidder.
2. Forms F-4 & F-16 are not to be filled-up/ submitted at this stage as these will be executed only with the successful bidder. However, successful bidder will have to submit the formats strictly as per the prescribed content without any deviation.

**11.1.2 ENVELOPE-II: Price Bid**

- i) The Prices are to be submitted strictly as per the Schedule of Rate of the bidding documents. TFL/PDIL shall not be responsible for any failure on the part of the bidder to follow the instructions.
- ii) Bidders are advised NOT to mention Rebate/Discount separately, either in the SOR format or anywhere else in the offer. In case Bidder(s) intend to offer any Rebate/Discount, they should include the same in the item rate(s) itself under the "Schedule of Rates (SOR)" and indicate the discounted unit rate(s) only.
- iii) If any unconditional rebate has been offered in the quoted rate the same shall be considered in arriving at evaluated price. However no cognizance shall be taken for any conditional discount for the purpose of evaluation of the bids.
- iv) In case, it is observed that any of the bidder(s) has/have offered suo-moto Discount/Rebate after opening of unpriced bid but before opening of price bids such discount /rebate(s) shall not be considered for evaluation. However, in the event of the bidder emerging as the lowest evaluated bidder without considering the discount/rebate(s), then such discount/rebate(s) offered by the bidder shall be considered for Award of Work and the same will be conclusive and binding on the bidder.
- v) In the event as a result of techno-commercial discussions or pursuant to seeking clarifications / confirmations from bidders, while evaluating the un-priced part of the bid, any of the bidders submits a sealed envelope stating that it contains revised prices; such bidder(s) will be requested to withdraw the revised prices failing which the bid will not be considered for further evaluation.
- vi) In case any bidder does not quote for any item(s) of "Schedule of Rates" and the estimated price impact is more than 10% of the quoted price, then the bid will be rejected. If such price impact of unquoted items is 10% or less of his quoted price, then the unquoted item(s) shall be loaded highest of the price quoted by the other bidders. If such bidder happens to be lowest evaluated bidder, price of unquoted items shall be considered as included in the quoted bid price.

	<b>ELECTRICAL WORKS (SUPPLY &amp; ERECTION) FOR ALTERNATE POWER SUPPLY ARRANGEMENT OF VIKARMPUR GUEST HOUSE AT TALCHER FERTILIZERS LTD., ANGUL, ODISHA</b>	PC-183/E/ 8001 /S-III	0	
		DOC. NO.	REV	
		Page 24 of 115		

11.2 In case the bids are invited through CPP portal, bidders are requested to refer instructions for participating in CPP portal enclosed herewith as **Annexure-III**. Bids submitted manually shall be rejected. The bids must be submitted on CPP portal only as follows :-

11.2.1 **PART-I: “TECHNO-COMMERCIAL/UN-PRICED BID”** comprising all the above documents mentioned at 11.1.1 along with Bid Security Declaration, ~~EMD/Bid Bond~~, copy of Power of Attorney and copy of integrity pact should be uploaded in the area earmarked in the CPP portal.

Further, Bidders must submit the **original** Bid Security Declaration, ~~EMD~~, Power of Attorney and Integrity Pact and any other documents specified in the Tender Document to the address mentioned in IFB, in a sealed envelope, superscribing the details of Tender Document (i.e. tender number & tender for) within 7 days from the date of un-priced bid opening.

~~Bidders are required to submit the EMD in original by Due Date and Time of Bid Submission or upload a scanned copy of the same in the Part-I of the Bid. If the Bidder is unable to submit EMD in original by Due Date and Time of Bid Submission, the Bidder is required to upload a scanned copy of the EMD in the e-bid, provided the original EMD, copy of which has been uploaded, is received within 7 days from the Due Date of Bid Opening, failing which the Bid will be rejected irrespective of their status/ranking in tendering process and notwithstanding the fact that a copy of EMD was earlier uploaded by the Bidder.~~

11.2.2 **PART-II: PRICE BID**

The Prices are to be filled strictly in the “Schedule of Rates” of the bidding documents and provision mentioned at para 11.1.2 hereinabove and to be uploaded in CPP portal.

11.3 In case of bids invited under *single bid system*, a single envelope containing all documents specified at Clause 11.1.1 & 11.1.2 of ITB above form the BID. All corresponding conditions specified at Clause 11.1.1 & 11.1.2 of ITB shall become applicable in such a case.

## 12. **SCHEDULE OF RATES / BID PRICES**

12.1 Unless stated otherwise in the Bidding Documents, the Contract shall be for the whole works as described in Bidding Documents, based on the rates and prices submitted by the Bidder and accepted by the Employer.

12.2 Prices must be filled in format for "Schedule of Rates [SOR]" enclosed as part of Tender document. If quoted in separate typed sheets and any variation in item description, unit or quantity is noticed; the Bid is liable to be rejected.

12.3 Bidder shall quote for all the items of "SOR" after careful analysis of cost involved for the performance of the completed item considering all parts of the Bidding Document. In case any activity though specifically not covered in description of item under "SOR" but is required to complete the works as per Specifications, Scope of Work/ Service, Standards, General Conditions of Contract (“GCC”), Special Conditions of Contract (“SCC”) or any other part of Bidding Document, the prices quoted shall deemed to be inclusive of cost incurred for such activity.

12.4 All duties, taxes and other levies [if any] payable by the Contractor under the Contract, or for any other cause except final **GST (CGST & SGST/ UTGST or IGST)** shall be included in the rates / prices and the total bid-price submitted by the Bidder.

	<b>ELECTRICAL WORKS (SUPPLY &amp; ERECTION) FOR ALTERNATE POWER SUPPLY ARRANGEMENT OF VIKARMPUR GUEST HOUSE AT TALCHER FERTILIZERS LTD., ANGUL, ODISHA</b>	PC-183/E/ 8001 /S-III	0	
		DOC. NO.	REV	
		Page 25 of 115		

- 12.5 Prices quoted by the Bidder, shall remain firm and fixed and valid until completion of the Contract and will not be subject to variation on any account. Any new taxes & Duties, if imposed by the State/ Govt. of India after due date of bid submission but before the Contractual Delivery Date, shall be reimbursed to the contractor on submission of documentary evidence for proof of payment to State/ Govt. Authorities and after ascertaining it's applicability with respect to the contract.

If any new taxes and/or duties are imposed beyond Completion/ Contract period for reasons not due to Owner's default, such taxes and duties shall be to *Contractor's account*.

If any new taxes and/or duties are imposed beyond Completion / Contract period for reasons due to Owner's default, such taxes and duties shall be to Owner's account.

- 12.6 The Bidder shall quote the unit rates in 'figures' & words. There should not be any discrepancy between the prices indicated in figures and the price indicated in words. In case of any discrepancy, the same shall be dealt as per clause no. 30 of ITB.

### **13. GST (CGST & SGST/ UTGST or IGST)**

- 13.1 Bidders are required to submit copy of the GST Registration Certificate while submitting the bids wherever **GST (CGST & SGST/UTGST or IGST)** is applicable.
- 13.2 Quoted prices should be inclusive of all taxes and duties, except **GST (CGST & SGST or IGST or UTGST)**. Please note that the responsibility of payment of **GST (CGST & SGST or IGST or UTGST)** lies with the Supplier of Goods / Services only. Supplier of Goods / Services (Service Provider) providing taxable service shall issue an Invoice/ Bill/e-Invoice, as the case may be as per rules/ regulation of GST. Further, returns and details required to be filled under GST laws & rules should be timely filed by Supplier of Goods / Services (Service Provider) with requisite details.

Payments to Service Provider for claiming **GST (CGST & SGST/UTGST or IGST)** amount will be made provided the above formalities are fulfilled. Further, OWNER may seek copies of challan and certificate from Chartered Accountant for deposit of **GST (CGST & SGST/UTGST or IGST)** collected from Owner.

- 13.3 The bidder confirms that it has included all taxes, duties, levies etc., as applicable at prevailing rates, in its CONTRACT PRICE. In case, bidder has not included any such taxes, duties, levies etc., at all and/or at prevailing rates (deliberately or otherwise) and it becomes leviable during execution of the contract, then such bidder has to pay all such taxes, duties, levies etc. and OWNER shall not be liable for payment of such liabilities and/or OWNER shall not reimburse such taxes, duties, levies etc. to the CONTRACTOR.

	<b>ELECTRICAL WORKS (SUPPLY &amp; ERECTION) FOR ALTERNATE POWER SUPPLY ARRANGEMENT OF VIKARMPUR GUEST HOUSE AT TALCHER FERTILIZERS LTD., ANGUL, ODISHA</b>	PC-183/E/ 8001 /S-III	0	
		DOC. NO.	REV	
		Page 26 of 115		

13.4 In case CBIC (Central Board of Indirect Taxes and Customs)/ any equivalent Central Government agency/ State Government agency brings to the notice of OWNER that the Supplier of Goods / Services (Service Provider) has not remitted the amount towards **GST (CGST & SGST/UTGST or IGST)** collected from OWNER to the government exchequer, then, that Supplier of Goods/ Services (Service Provider) shall be put under Holiday list of OWNER for period of six months as mentioned in Procedure for Evaluation of Performance of Vendors/ Suppliers/Contractors/ Consultants. This action will be in addition to the right of recovery of financial implication arising on TFL.

13.5 In case of statutory variation in **GST (CGST & SGST/UTGST or IGST)**, other than due to change in turnover, payable on the contract value during contract period, the Supplier of Goods / Services (Service Provider) shall submit a copy of the 'Government Notification' to evidence the rate as applicable on the Bid due date and on the date of revision.

Beyond the contract period, any increase in the rate of **GST (CGST & SGST/UTGST or IGST)** beyond the contractual delivery period shall be to Service Provider's account whereas any decrease in the rate **GST (CGST & SGST/UTGST or IGST)** shall be passed on to the Owner.

Claim for payment of **GST (CGST & SGST/UTGST or IGST)**/ Statutory variation, should be raised within two [02] months from the date of issue of 'Government Notification' for payment of differential (in %) **GST (CGST & SGST/UTGST or IGST)**, otherwise claim in respect of above shall not be entertained for payment of arrears.

The base date for the purpose of applying statutory variation shall be the Bid Due Date.

OWNER will reimburse **GST (CGST & SGST/UTGST or IGST)** to the Service Provider at actuals against submission of Tax Invoices as per format specified in rules/ regulation of GST subject to the ceiling amount of **GST (CGST & SGST/UTGST or IGST)** as quoted by the bidder, subject to any statutory variations, except variations arising due to change in turnover. In case of any variation in the executed quantities (If directed and/or certified by the Engineer-In-Charge) the ceiling amount on which **GST (CGST & SGST/UTGST or IGST)** is applicable will be modified on pro-rata basis.

Any reduction in the amount of GST resulting from a reduction in the rate of GST or remission or exemption from GST with respect to Services provided to the OWNER shall be refundable to the OWNER at actuals during the Completion / Contract Period and also during the delayed Completion / Contract Period, if any.

In case of delayed completion beyond the COMPLETION PERIOD, even though extension of completion time is allowed by OWNER, for reasons solely attributable to Contractor, all extra costs on account of changes of statutory regulations/ acts, or shall not apply to the Contract price and shall be borne by the CONTRACTOR. However, any decrease in taxes and duties during the delayed period shall be passed on to the OWNER.

In case the COMPLETION PERIOD is extended for reasons solely attributable to OWNER, then any increase on account of statutory changes in GST until the extended period shall be borne by OWNER. Further, any new taxes, duties, cess, levies notified or imposed after the submission of Price Bid during such extended COMPLETION PERIOD shall be to OWNER's Account

	<b>ELECTRICAL WORKS (SUPPLY &amp; ERECTION) FOR ALTERNATE POWER SUPPLY ARRANGEMENT OF VIKARPUR GUEST HOUSE AT TALCHER FERTILIZERS LTD., ANGUL, ODISHA</b>	PC-183/E/ 8001 /S-III	0	
		DOC. NO.	REV	
		Page 27 of 115		

- 13.6 OWNER will prefer to deal with registered supplier of goods/ services under GST. Therefore, bidders are requested to get themselves registered under GST, if not registered yet.

However, in case any unregistered bidder is submitting their bid, their prices will be loaded with applicable **GST (CGST & SGST/UTGST or IGST)** while evaluation of bid (if applicable as per Govt. Act/ Law in vogue).

- 13.7 In case OWNER is required to pay entire/certain portion of applicable **GST (CGST & SGST/UTGST or IGST)** and remaining portion, if any, is to be deposited by Bidder directly as per **GST (CGST & SGST/UTGST or IGST)** laws, entire applicable rate/amount of **GST (CGST & SGST/UTGST or IGST)** to be indicated by bidder in the SOR.

Where OWNER has the obligation to discharge **GST (CGST & SGST/UTGST or IGST)** liability under reverse charge mechanism and OWNER has paid or is liable to pay **GST (CGST & SGST/UTGST or IGST)** to the Government on which interest or penalties becomes payable as per GST laws for any reason which is not attributable to TFL or ITC with respect to such payments is not available to OWNER for any reason which is not attributable to OWNER, then OWNER shall be entitled to deduct/ setoff / recover such amounts against any amounts paid or payable by OWNER to Contractor / Supplier.

- 13.8 Contractor shall ensure timely submission of e-Invoice(s)/invoice(s) as per rules/ regulations of GST with all required supporting document(s) within a period specified in Contracts/ LOA to enable OWNER to avail input tax credit. Further, returns and details required to be filled under GST laws & rules should be timely filed by supplier with requisite details.

If input tax credit with respect to **GST (CGST & SGST/ UTGST or IGST)** is not available to OWNER for any reason which is not attributable to OWNER, then OWNER shall not be obligated or liable to pay or reimburse **GST (CGST & SGST/UTGST or IGST)** charged in the invoice(s) and shall be entitled to / deduct/ setoff /recover the such **GST (CGST & SGST/UTGST or IGST UTGST)** thereupon together with all penalties and interest if any, against any amounts paid or payable by OWNER in future to the Service Provider under this contract or under any other contract.

### 13.9 RECONCILIATION BETWEEN GSTR2A AND INPUT TAX CREDIT

Supplier shall ensure timely submission of correct e-Invoice(s)/invoice(s), as per GST rules/ regulation, with all required supporting document(s) within a period specified in Contract to enable TFL to avail input credit of GST (CGST &SGST/UTGST or IGST). Further, returns and details required to be filled under GST laws & rules should be timely filed by Supplier of Goods/ Services with requisite details.

If input Tax credit is not available to TFL for any reason not attributable to TFL, then TFL shall not be obligated or liable to pay or reimburse GST (CGST &SGST/ UTGST or IGST) claimed in the invoice(s) and shall be entitled to deduct/ setoff/ recover such GST amount (CGST &SGST/ UTGST or IGST) or Input Tax Credit amount together with penalties and interest, if any, against any amounts paid or becomes payable by TFL in future to the Supplier/Contractor under this contract or under any other contract.



	<b>ELECTRICAL WORKS (SUPPLY &amp; ERECTION) FOR ALTERNATE POWER SUPPLY ARRANGEMENT OF VIKARMPUR GUEST HOUSE AT TALCHER FERTILIZERS LTD., ANGUL, ODISHA</b>	PC-183/E/ 8001 /S-III	0	
		DOC. NO.	REV	
		Page 28 of 115		

In case CBIC (Central Board of Indirect Taxes and Customs)/ any tax authority/ any equivalent government agency brings to the notice of TFL that the Supplier has not remitted the amount towards GST (CGST &SGST/IGST) collected from TFL to the government exchequer, then, that Supplier shall be put under Holiday list of TFL for period of six months as mentioned in Procedure for Evaluation of Performance of Vendors/Suppliers/ Contractors/ Bidders. This action will be in addition to the right of recovery of financial implication arising on TFL.

**13.10** The amount of statutory levies like, CGST, SGST & IGST will be released when the same will appear in the GSTR-2A of OWNER, in the common portal of GST and Bidder has filed the valid return in accordance with the provisions of the GST act and the rules made there under. If, input tax credit is not available to OWNER for any reason attributable to the bidder, then OWNER shall not be obligatory or liable to pay or reimburse GST claimed in invoice and shall be entitled to deduct /setoff/ recover such GST together with all the penalty and interest if any, against any amount paid or payable to bidder. Further in this case, OWNER reserves the right to upload the name of such defaulter on the Company website and may also consider for putting under Holiday list of OWNER for period of six months as mentioned in Procedure for Evaluation of Performance of Vendors/ Suppliers/ Contractors/Bidders.

**13.11 Anti-profiteering clause**

As per Clause 171 of GST Act it is mandatory to pass on the benefit due to reduction in rate of tax or from input tax credit to the consumer by way of commensurate reduction in prices. The Supplier of Goods / Services may note the above and quote their prices accordingly.

**13.12** In case the GST rating of vendor on the GST portal / Govt. official website is negative/ black listed, then the bids may be rejected by OWNER. Further, in case rating of bidder is negative / black listed after award of work for supply of goods/ services, then OWNER shall not be obligated or liable to pay or reimburse GST to such vendor and shall also be entitled to deduct / recover such GST along with all penalties/ interest, if any, incurred by OWNER.

Wherever TDS under GST Laws has been deducted from the Tax invoices raised /payments made to the vendors, as per the provisions of the GST law / Rules, Vendors should accept the corresponding GST-TDS amount populated in the relevant screen on GST common portal ([www.gst.gov.in](http://www.gst.gov.in)). Further, Vendors should also download the GST TDS certificate from GST common portal (reference path: Services>User Services>View/Download Certificates option).

**13.13 Provision w.r.t. E- Invoicing requirement as per GST laws**

Contractor (s) who is required to comply with the requirements of E-invoice for B2B transactions as per the requirement of GST Law will ensure the compliance of requirement of E Invoicing under GST law. If the invoice issued without following this process, such invoice can-not be processed for payment by TFL as no ITC is allowed on such invoices.

Therefore, all the payments to such contractor who is liable to comply with e-invoice as per GST Laws shall be made against the proper e-invoice(s) only. Further, returns and details required to be filled under GST laws & rules against such e-invoices should be timely filed by Contractor with requisite details.

	<b>ELECTRICAL WORKS (SUPPLY &amp; ERECTION) FOR ALTERNATE POWER SUPPLY ARRANGEMENT OF VIKARMPUR GUEST HOUSE AT TALCHER FERTILIZERS LTD., ANGUL, ODISHA</b>	PC-183/E/ 8001 /S-III	0	
		DOC. NO.	REV	
		Page 29 of 115		

If input tax credit is not available to TFL for any reason attributable to contractor (both for E-invoicing cases and non-E-invoicing cases), then TFL shall not be obligated or liable to pay or reimburse GST (CGST & SGST/UTGST or IGST) claimed in the invoice(s) and shall be entitled to deduct / setoff / recover such GST amount (CGST & SGST/UTGST or IGST) or Input Tax Credit amount together with penalties and interest, if any, by adjusting against any amounts paid or becomes payable in future to the contractor under this contract or under any other contract.

To ensure compliance, undertaking in requisite format is to be submitted by Contractor as per format enclosed at Form **F-25** along with documents for release of payment.

**13.14 Provision w.r.t. TCS on Sale of Goods under section 206C(1H) of Income Tax Act (Applicable only in case of procurement of Goods)**

As per section 206C(1H) of the Income Tax Act, 1961 inserted by Finance Act 2020, a seller (as defined under the said section), who receives any amount as consideration for sale of any goods to a buyer (as defined under the provision) of the value or aggregate of such value exceeding fifty lakh rupees in any previous year, shall levy at the time of sale, TCS for a sum equal to % as defined (Presently 0.1 per cent) of the sale consideration exceeding fifty lakh rupees (or limit as specified in the Act) and deposit the same with Government on receipt/collection of consideration from TFL.

TFL will avail TCS credit and adjust such TCS credit against its income tax liability on the basis of TCS certificate to be issued by seller to TFL.

**14 BID CURRENCIES:**

Bidders must submit bid in Indian Rupees only.

**15 BID VALIDITY**

15.1 Bids shall be kept valid for period specified in BDS from the final Due date of submission of bid'. A Bid valid for a shorter period may be rejected by OWNER as 'non-responsive'.

15.2 In exceptional circumstances, prior to expiry of the original 'Bid Validity Period', the Employer may request the Bidders to extend the 'Period of Bid Validity' for a specified additional period. The request and the responses thereto shall be made in writing or by fax/email. A Bidder may refuse the request without forfeiture of his EMD. A Bidder agreeing to the request will not be required or permitted to modify his Bid, but will be required to extend the validity of its EMD for the period of the extension and in accordance with "ITB: Clause-16" in all respects.

**16 EARNEST MONEY DEPOSIT**

16.1 Wherever BID SECURITY/ EMD is appearing in the NIT, the same shall be read as "NOT APPLICABLE". In lieu of BID SECURITY/ EMD, bidder has to submit Declaration for Bid Security as per format (F-2).

**17 PRE-BID MEETING**

~~17.1 The Bidder(s) or his designated representative are invited to attend a "Pre Bid Meeting" which will be held at address specified in IFB, SI No. 2.0 (I) of IFB. It is expected that a bidder shall not depute more than 02 representatives for the meeting.~~

	<b>ELECTRICAL WORKS (SUPPLY &amp; ERECTION) FOR ALTERNATE POWER SUPPLY ARRANGEMENT OF VIKARMPUR GUEST HOUSE AT TALCHER FERTILIZERS LTD., ANGUL, ODISHA</b>	PC-183/E/ 8001 /S-III	0	
		DOC. NO.	REV	
		Page 30 of 115		

~~17.2 Purpose of the meeting will be to clarify issues and to answer questions on any matter that may be raised at that stage.~~

~~17.3 Text of the questions raised and the responses given, together with any responses prepared after the meeting, will be uploaded on websites as mentioned at Sl. No. **2.0 (H) of IFB**. Any modification of the Contents of Bidding Documents listed in "ITB: Clause 7.1", that may become necessary as a result of the Pre-Bid Meeting shall be made by the Employer exclusively through the issue of an Addendum / Corrigendum pursuant to "ITB: Clause 9", and not through the minutes of the Pre-Bid Meeting.~~

~~17.4 Non-attendance of the Pre-Bid Meeting will not be a cause for disqualification of Bidder.~~

#### **18. FORMAT AND SIGNING OF BID**

18.1 The original and all copies of the Bid shall be typed or written in indelible ink [in the case of copies, photocopies are also acceptable] and shall be signed by a person or persons duly authorized to sign on behalf of the Bidder (as per POA). The name and position held by each person signing, must be typed or printed below the signature. All pages of the Bid except for un-amended printed literature where entry(s) or amendment(s) have been made shall be initialed by the person or persons signing the Bid.

18.2 The Bid shall contain no alterations, omissions, or additions, unless such corrections are initiated by the person or persons signing the Bid.

18.3 In case of e-tendering, digitally signed documents to be uploaded as detailed in addendum to ITB.

#### **19. ZERO DEVIATION AND REJECTION CRITERIA**

19.1 ZERO DEVIATION: Deviation to terms and conditions of "Bidding Documents" may lead to rejection of bid. OWNER will accept bids based on terms & conditions of "Bidding Documents" only. Bidder may note OWNER will determine the substantial responsiveness of each bid to the Bidding Documents pursuant to provision contained in clause 29 of ITB. For purpose of this, a substantially responsive bid is one which conforms to all terms and conditions of the Bidding Documents without deviations or reservations. OWNER's determination of a bid's responsiveness is based on the content of the bid itself without recourse to extrinsic evidence.

OWNER reserves the right to raise technical and/or commercial query(s), if required, may be raised on the bidder(s).

The response(s) to the same shall be in writing, and no change in the price(s) or substance of the bids shall be sought, offered or permitted. The substance of the bid includes but not limited to prices, completion, scope, technical specifications, etc. Bidders are requested to not to take any deviation/exception to the terms and conditions laid down in this "Tender Documents", and submit all requisite documents as mentioned in this "Tender Documents", failing which their offer will be liable for rejection. If a bidder does not reply to the queries in the permitted time frame then its bid shall be evaluated based on the documents available in the bid.

19.2 **REJECTION CRITERIA:** Notwithstanding the above, deviation to the following clauses of Tender document shall lead to summarily rejection of Bid:



	<b>ELECTRICAL WORKS (SUPPLY &amp; ERECTION) FOR ALTERNATE POWER SUPPLY ARRANGEMENT OF VIKARPUR GUEST HOUSE AT TALCHER FERTILIZERS LTD., ANGUL, ODISHA</b>	PC-183/E/ 8001 /S-III	0	
		DOC. NO.	REV	
		Page 31 of 115		

- (a) Firm Price
- (b) Bid Security Declaration
- (c) Specifications & Scope of Work
- (d) Schedule of Rates / Price Schedule / Price Basis
- (e) Duration / Period of Contract/ Completion schedule
- (f) Period of Validity of Bid
- (g) Price Reduction Schedule
- (h) Contract Performance Security
- (i) Guarantee / Defect Liability Period
- (j) Arbitration / Resolution of Dispute/Jurisdiction of Court
- (k) Force Majeure & Applicable Laws
- (l) Integrity Pact, if Applicable
- (m) Undertaking forms, Form-20 & Form-21 of Annexure-VI.
- (n) Bidder quoting less than 20% as minimum Local content (as per make in India PP-LC policy 2020)
- (o) Any other condition specifically mentioned in the tender document elsewhere that non-compliance of the clause lead to rejection of bid

## 20. **PAYMENT**

OWNER has initiated payments to Suppliers and Contractors through RTGS/ NEFT. The successful bidder should give the details of his bank account as per the E-Banking Mandate Form (F-12).

## **[D] – SUBMISSION OF BIDS**

### 21. **SUBMISSION, SEALING AND MARKING OF BIDS**

- 21.1 Bids shall be submitted through CPP portal in the manner specified in tender document. No Manual/ Hard Copy (Original) offer shall be acceptable.
- 21.2 All the bids shall be addressed to the Consultant at address specified in IFB.
- 21.3 Bids submitted under the name of AGENT/ CONSULTANT/ REPRESENTATIVE/ RETAINER/ ASSOCIATE etc. on behalf of a bidder/affiliate shall not be accepted.

### 22. **DEADLINE FOR SUBMISSION OF BIDS**

- 22.1 Bids must be submitted through CPP portal not later than the date and time specified in the tender documents/BDS.
- 22.2 OWNER may, in exceptional circumstances and at its discretion, extend the deadline for submission of Bids (Clause 9 of ITB refers), in which case all rights and obligations of OWNER and the Bidders, previously subject to the original deadline will thereafter be subject to the deadline as extended. Notice for extension of due date of submission of bid will be uploaded on website/ communicated to the bidders.

	<b>ELECTRICAL WORKS (SUPPLY &amp; ERECTION) FOR ALTERNATE POWER SUPPLY ARRANGEMENT OF VIKARPUR GUEST HOUSE AT TALCHER FERTILIZERS LTD., ANGUL, ODISHA</b>	PC-183/E/ 8001 /S-III	0	
		DOC. NO.	REV	
		Page 32 of 115		

**23. LATE BIDS**

- 23.1 Any bids received after the notified date and time of closing of tenders will be treated as late bids.
- 23.2 Tender on CPP portal shall close immediately after the due date for submission of bid and no bids can be submitted thereafter.

Where the bid bond/physical documents have been received but the bid is not submitted by the bidder in the CPP portal, such bid bond/ physical documents shall be returned immediately.

- 23.3 Unsolicited Bids or Bids received to address other than one specifically stipulated in the tender document will not be considered for evaluation/opening/award if not received to the specified destination within stipulated date & time.

**24. MODIFICATION AND WITHDRAWAL OF BIDS**

- 24.1 The bidder may withdraw or modify its bid after bid submission but before the due date and time for submission as per tender document.
- 24.2 The modification shall also be prepared, sealed, marked and dispatched in accordance with the provisions of the clause 11 & 22 of ITB with relevant 'Cut-Out Slip' duly pasted and mentioning on top of the envelope as "MODIFICATION". In case of withdrawal of bid, the Envelope containing withdrawal letter duly super scribing the envelope as "WITHDRAWAL" and "Tender Document number :...."/ communication regarding withdrawal of bid with "Tender Document number :...."/ must reach concerned dealing official of OWNER within Due date & Time of submission of Bid. No bid shall be modified/ withdrawn after the Due Date & Time for Bid submission.
- 24.3 Any withdrawal/ modification/substitution of Bid in the interval between the Due Date & Time for Bid submission and the expiration of the period of bid validity specified by the Bidder in their Bid shall result in the Bidder's forfeiture of EMD pursuant to clause 16 of ITB and rejection of Bid.
- 24.4 The latest Bid submitted by the Bidder shall be considered for evaluation and all other Bid(s) shall be considered to be unconditionally withdrawn.
- 24.5 In case after price bid opening, the lowest evaluated bidder (L1) is not awarded the job for any mistake committed by him in bidding or withdrawal of bid or modification of bid or varying any term in regard thereof leading to re-tendering, OWNER shall forfeit EMD paid by the bidder and such bidders shall be debarred from participation in re-tendering of the same job(s)/item(s). Further, such bidder will be put on holiday for a period of six months after following the due procedure.

**25. EMPLOYER'S RIGHT TO ACCEPT ANY BID AND TO REJECT ANY OR ALL BIDS**

OWNER reserves the right to accept or reject any Bid, and to annul the Bidding process and reject all Bids, at any time prior to award of Contract, without thereby incurring any liability to the affected Bidder or Bidders or any obligations to inform the affected Bidder or Bidders of the ground for OWNER's action. However, bidder, if so desires, may seek the reason (in writing) for rejection of their Bid to which OWNER shall respond quickly.

	<b>ELECTRICAL WORKS (SUPPLY &amp; ERECTION) FOR ALTERNATE POWER SUPPLY ARRANGEMENT OF VIKARPUR GUEST HOUSE AT TALCHER FERTILIZERS LTD., ANGUL, ODISHA</b>	PC-183/E/ 8001 /S-III	0	
		DOC. NO.	REV	
		Page 33 of 115		

## **[E] – BID OPENING AND EVALUATION**

### **26. BID OPENING**

#### **26.1 *Un-priced Bid Opening :***

OWNER will open bids, in the presence of bidders' designated representatives who choose to attend, at date, time and location stipulated in the BDS. The bidders' representatives, who are present, shall sign a bid opening register evidencing their attendance.

#### **26.2 *Priced Bid Opening:***

26.2.1 OWNER will open the price bids of those bidders who meet the qualification requirement and whose bid is determined to be technically and commercially responsive. Bidders selected for opening of their price bids shall be informed about the date of price bid opening. Bidders may depute their authorized representative to attend the bid opening. The bidders' representatives, who are present shall sign a register evidencing their attendance and may be required to be present on a short notice.

26.2.2 The price bids of those Bidders who were not found to be techno-commercially responsive shall not be opened.

26.3 In case of bids invited under the single bid system, bid shall be opened on the specified due date & time.

### **27. CONFIDENTIALITY**

Information relating to the examination, clarification, evaluation and comparison of Bids, and recommendations for the award of a Contract, shall not be disclosed to Bidder(s) or any other persons not officially concerned with such process.

### **28. CONTACTING THE EMPLOYER**

28.1 From the time of Bid opening to the time of award of Contract, if any Bidder wishes to contact the Employer on any matter related to the Bid, it should do so in writing. Information relating to the examination, clarification, evaluation & recommendation for award shall not be disclosed.

28.2 Any effort by the Bidder to influence the Employer in the Employer's 'Bid Evaluation', 'Bid Comparison', or 'Contract Award' decisions may result in the rejection of the Bidder's Bid and action shall be initiated as per procedure in this regard.

### **29. EXAMINATION OF BIDS AND DETERMINATION OF RESPONSIVENESS**

29.1 The owner's determination of a bid's responsiveness is based on the content of the bid only. Prior to the detailed evaluation of Bids, the Employer will determine whether each Bid:-

- (a) Meets the "Bid Evaluation Criteria" of the Bidding Documents;
- (b) Has been properly signed;
- (c) Is accompanied by the required 'Earnest Money / Bid Security';

	<b>ELECTRICAL WORKS (SUPPLY &amp; ERECTION) FOR ALTERNATE POWER SUPPLY ARRANGEMENT OF VIKARMPUR GUEST HOUSE AT TALCHER FERTILIZERS LTD., ANGUL, ODISHA</b>	PC-183/E/ 8001 /S-III	0	
		DOC. NO.	REV	
		Page 34 of 115		

- (d) Is substantially responsive to the requirements of the Bidding Documents; and
- (e) Provides any clarification and/or substantiation that the Employer may require to determine responsiveness pursuant to "ITB: Clause-29.2"

29.2 A substantially responsive Bid is one which conforms to all the terms, conditions and specifications of the Bidding Documents without material deviations or reservations or omissions for this purpose employer defines the foregoing terms below:-

- a) "Deviation" is departure from the requirement specified in the tender documents.
- b) "Reservation" is the setting of limiting conditions or withholding from complete acceptance of the requirement in the tender documents.
- c) "Omission" is the failure to submit part or all of the information or documentation required in the tender document.

29.3 A material deviation, reservation or omission is one that,

- a) If accepted would,
  - i) Affect in any substantial way the scope, quality, or performance of the job as specified in tender documents.
  - ii) Limit, in any substantial way, inconsistent with the Tender Document, the Employer's rights or the tenderer's obligations under the proposed Contract.
- b) If rectified, would unfairly affect the competitive position of other bidders presenting substantially responsive bids.

29.4 The employer shall examine all aspects of the bid to confirm that all requirements have been met without any material deviation, reservation or omission.

29.5 If a Bid is not substantially responsive, it may be rejected by the Employer and may not subsequently be made responsive by correction or withdrawal of the of material deviation, reservation or omission.

### 30. CORRECTION OF ERRORS

Arithmetic Correction of Errors (if any) in multiplication to derive the total cost of an individual item shall be done by the Consultant based on the quoted Unit Price by the Bidder. If the bidder does not accept the corrected amount of bid, its bid will be rejected. ~~and the Bid security shall be forfeited.~~

### 31. CONVERSION TO SINGLE CURRENCY FOR COMPARISON OF BIDS

**Not Applicable.** All bids submitted must be in the currency specified at clause 14 of ITB.

### 32. EVALUATION AND COMPARISON OF BIDS

Bid shall be evaluated as per evaluation criteria mentioned in Section-II of bidding documents.

In case of a tie at the lowest bid (L1) position between two or more startup/non-startup bidders, the order/LOA will be placed on the bidder who has higher/ highest turnover in last audited financial year.

	<b>ELECTRICAL WORKS (SUPPLY &amp; ERECTION) FOR ALTERNATE POWER SUPPLY ARRANGEMENT OF VIKARMPUR GUEST HOUSE AT TALCHER FERTILIZERS LTD., ANGUL, ODISHA</b>	PC-183/E/ 8001 /S-III	0	
		DOC. NO.	REV	
		Page 35 of 115		

**33. COMPENSATION FOR EXTENDED STAY [FOR APPLICABILITY OF THIS CLAUSE REFER BDS]:-**

- 33.1 In the event of the time of completions of work getting delayed beyond the time schedule indicated in the bidding document plus a grace period equivalent to 1/5<sup>th</sup> of the time schedule or 2 months whichever is more, due to reasons solely attributable to Employer, the Contractor shall be paid compensation for extended stay (ESC) to maintain necessary organizational set up and construction tools, tackles, equipment etc. at site of work.
- 33.2 The bidder is required to specify the rate for ESC on per month basis in the “PRICE PART” of his bid, which shall be considered for loading on total quoted price during price bid evaluation. The loading shall be done of a period of 1/5<sup>th</sup> of the time schedule or 1 month whichever is less. In case bidder does not indicate the rate for ESC in price part of his bid, it will be presumed that no ESC is required by the bidder and evaluation shall be carried out accordingly.

**34. PURCHASE PREFERENCE**

Considering that the subject work falls under "Works Contract Services", Purchase preference to MSE Bidders shall not be applicable as per government guidelines.

Purchase preference to Central government public sector Undertaking shall be allowed as per Government instructions in vogue.

**[F] – AWARD OF CONTRACT**

**35. AWARD**

Subject to "ITB: Clause-29", OWNER will award the Contract to the successful Bidder whose Bid has been determined to be substantially responsive and has been determined as the lowest provided that bidder, is determined to be qualified to satisfactorily perform the Contract.

***“OWNER intent to place the order/contract directly on the address from where Goods are produced/dispatched are Services are rendered. In case, bidder wants order/ contract at some other address or supply of Goods/ Services from multiple locations, bidder is required to provide in their bid address on which order is to be placed”.***

**36. NOTIFICATION OF AWARD / FAX OF ACCEPTANCE**

- 36.1 Prior to the expiry of ‘Period of Bid Validity’, Notification of Award for acceptance of the Bid will be intimated to the successful Bidder by OWNER either by Fax/ E - mail /Letter or like means defined as the “Fax of Acceptance (FOA)”.

	<b>ELECTRICAL WORKS (SUPPLY &amp; ERECTION) FOR ALTERNATE POWER SUPPLY ARRANGEMENT OF VIKARMPUR GUEST HOUSE AT TALCHER FERTILIZERS LTD., ANGUL, ODISHA</b>	PC-183/E/ 8001 /S-III	0	
		DOC. NO.	REV	
		Page 36 of 115		

The Contract shall enter into force on the date of FOA and the same shall be binding on OWNER and successful Bidder (i.e. Contractor/Service Provider). The Notification of Award/FOA will constitute the formation of a Contract. The "Detailed Letter of Acceptance (DLOA)" shall be issued thereafter incorporating terms & conditions of Tender Document, Amendments, Corrigendum, Clarification(s), Bid and agreed variation(s)/acceptable deviation(s), if any. OWNER may choose to issue Notification of Award in form of detailed Letter of Acceptance without issuing FOA and in such case the Contract shall enter into force on the date of detailed Letter of Acceptance only.

- 36.2 Contract period shall commence from the date of "Notification of Award" or as mentioned in the Notification of Award. The "Notification of Award" will constitute the formation of a Contract, until the Contract has been effected pursuant to signing of Contract Agreement as per "ITB: Clause-37".

Upon the successful Bidder's / Contractor's furnishing of 'Contract Performance Security / Security Deposit', pursuant to "ITB: Clause-38", OWNER will promptly discharge his 'Earnest Money / Bid Security', pursuant to "ITB: Clause-16"

- 36.3 The Order/ contract value mentioned above is subject to Price Reduction Schedule clause.

### **37. SIGNING OF AGREEMENT**

- 37.1 OWNER will award the Contract to the successful Bidder, who, within 'fifteen [15] days' of receipt of the same, shall sign and return the acknowledged copy to OWNER.
- 37.2 The successful Bidder/Contractor shall be required to execute an 'Agreement' in the proforma given in this Bidding Document (**Format F-16**) on a 'non-judicial stamp paper' of appropriate value [cost of the 'stamp-paper' shall be borne by the successful Bidder/Contractor] and of 'state' specified in Bidding Data Sheet (BDS) only, within 'fifteen [15] days' of receipt of the "Fax of Acceptance [FOA]" of the Tender by the successful Bidder/ Contractor failure on the part of the successful Bidder/ Contractor to sign the 'Agreement' within the above stipulated period, shall constitute sufficient grounds for forfeiture of EMD/ Security Deposit.

### **38. CONTRACT PERFORMANCE SECURITY / SECURITY DEPOSIT**

- 38.1 Within 30 days of the receipt of the notification of award/ Fax of Acceptance from OWNER, the successful bidder shall furnish the Contract Performance Security (CPS) in accordance with 'General Conditions of the Contract'. The CPS shall be in the form of either Banker's Cheque or Demand Draft or Bank Guarantee as per **Form F-4** and shall be in the currency of the Contract. **However, CPS shall not be applicable in cases where in the individual order/contract value as specified in Notification of Award is less than INR 5 Lakh (exclusive of GST).**
- 38.2 The contract performance security shall be for an amount equal to specified in Bidding Data Sheet (BDS) towards faithful performance of the contractual obligations and performance of equipment. For the purpose of CPS, Contract/order value shall be exclusive of **GST (CGST & SGST/UTGST or IGST).**

	<b>ELECTRICAL WORKS (SUPPLY &amp; ERECTION) FOR ALTERNATE POWER SUPPLY ARRANGEMENT OF VIKARPUR GUEST HOUSE AT TALCHER FERTILIZERS LTD., ANGUL, ODISHA</b>	PC-183/E/ 8001 /S-III	0	
		DOC. NO.	REV	
		Page 37 of 115		

Bank Guarantee towards CPS shall be from any Indian scheduled bank or a branch of an International bank situated in India and registered with Reserve Bank of India as scheduled foreign bank in case of Indian bidder as well as foreign bidder. However, in case of bank guarantees from banks other than the Nationalized Indian banks, the bank must be a commercial bank having net worth in excess of Rs 100 crores and a declaration to this effect should be made by such commercial bank either in the Bank Guarantee itself or separately on its letterhead.

- 38.3 Failure of the successful bidder to comply with the requirements of this article shall constitute sufficient grounds for the annulment of the award and forfeiture of the EMD.
- 38.4 CPBG/ Security Deposit will not be accepted in case the same has reference of 'remitter' / 'financer' other than bidder on the aforementioned financial instrument of CPBG/ Security.
- 38.5 The CPS has to cover the entire contract value including extra works/services also. As long as the CPS submitted at the time of award take cares the extra works/ services executed and total executed value are within the awarded contract price, there is no need for additional CPS. As soon as the total executed value is likely to burst the ceiling of awarded contract price, the contractor should furnish additional CPS.
- 38.6 In case of forfeiture of Contract Performance Security/ Security Deposit, the forfeited amount will be considered inclusive of tax and tax invoice will be issued by TFL. The forfeiture amount will be subject to final decision of TFL based on other terms and conditions of order/ contract.
- 38.7 The Contractor will also submit covering letter along with CPS as per format at **F-4**.
- 38.8 The Bidder shall submit the "Undertaking regarding submission of Contract Performance Security within stipulated time line" as per **Form F-24** with their bid.

**39. PROCEDURE FOR ACTION IN CASE CORRUPT/ FRAUDULENT/COLLUSIVE/ COERCIVE PRACTICES**

- 39.1 Procedure for action in case Corrupt/ Fraudulent/Collusive/Coercive Practices is enclosed at **Annexure-I**.

**39.2 NON-APPLICABILITY OF ARBITRATION CLAUSE IN CASE OF BANNING OF VENDORS/ SUPPLIERS/ CONTRACTORS/BIDDERS/ CONSULTANTS INDULGED IN FRAUDULENT/ COERCIVE PRACTICES**

Notwithstanding anything contained contrary in GCC and other "CONTRACT DOCUMENTS", in case it is found that the Vendors/ Suppliers / Contractors/Bidders/ Consultants indulged in fraudulent/ coercive practices at the time of bidding, during execution of the contract etc., and/or on other grounds as mentioned in OWNER's "Procedure for action in case Corrupt/Fraudulent/Collusive/Coercive Practices" (Annexure-I), the contractor/bidder shall be banned (in terms of aforesaid procedure) from the date of issuance of such order by OWNER, to such Vendors/ Suppliers / Contractors/Bidders/ Consultants.



	<b>ELECTRICAL WORKS (SUPPLY &amp; ERECTION) FOR ALTERNATE POWER SUPPLY ARRANGEMENT OF VIKARMPUR GUEST HOUSE AT TALCHER FERTILIZERS LTD., ANGUL, ODISHA</b>	PC-183/E/ 8001 /S-III	0	
		DOC. NO.	REV	
		Page 38 of 115		

The Vendor/ Supplier/ Contractor/ Bidder/Consultant understands and agrees that in such cases where Vendor/ Supplier / Contractor/ Bidder/Consultant has been banned (in terms of aforesaid procedure) from the date of issuance of such order by OWNER, such decision of OWNER shall be final and binding on such Vendor/ Supplier / Contractor/ Bidder/Consultant and the 'Arbitration clause' in the GCC and other "CONTRACT DOCUMENTS" shall not be applicable for any consequential issue /dispute arising in the matter.

#### 40. **PUBLIC PROCUREMENT POLICY FOR MICRO AND SMALL ENTERPRISES**

40.1 Following provision has been incorporated in tender for MSEs, in line with notification of Government of India, vide Gazette of India No. 503 dated 26.03.2012 proclaiming the Public Procurement Policy on procurement of goods and services from Micro and Small Enterprises (MSEs)

- i) Issue of tender document to MSEs free of cost.
- ii) Exemption to MSEs from payment of EMD/Bid Security.

40.2 In case bidder is a Micro or Small Enterprise under the Micro, Small and Medium Enterprises Development Act, 2006, the bidder shall submit the following:

- (i) Ministry of MSME vide Gazette notification no. CG-DL-E-26062020-220191 dated 26.06.2020 has notified certain criteria for classifying the enterprises as Micro, Small and Medium Enterprises and specified, form and procedure for filing the memorandum (Udyam Registration) w.e.f. 01.07.2020 (for complete details of policy refer website of Ministry of MSME i.e. <https://msme.gov.in>)

Accordingly, Micro and Small Enterprises (MSEs) shall be required to submit Udyam Registration Certificate for availing benefit under Public Procurement Policy for MSEs-2012

- (ii) An enterprises registered prior to 30.06.2020 and who are not re-registered with Udyam Registration, shall continue to be valid for a period upto 31.03.2021. Such enterprises shall submit EM Part-II or Udyog Aadhar Memorandum (UAM) for availing benefits of PPP-2012.

The above documents submitted by the bidder shall be duly certified by the Chartered Accountant (not being an employee or a Director or not having any interest in the bidder's company/firm) and notary public with legible stamp.

If the bidder does not provide the above confirmation or appropriate document or any evidence, then it will be presumed that they do not qualify for any preference admissible in the Public Procurement Policy (PPP) 2012.

Further, MSEs who are availing the benefits of the Public Procurement Policy (PPP) 2012 get themselves registered with MSME Data Bank being operated by NSIC, under SME Division, M/o MSME, in order to create proper data base of MSEs which are making supplies to CPSUs.

40.3 If against an order placed by TFL, successful bidder(s) (other than Micro/Small Enterprise) is procuring material/services from their sub-vendor who is a Micro or Small Enterprise registered with District Industries Centres or Khadi and Village Industries Commission or Khadi and Village Industries Board or Coir Board or National Small Industries Corporation or Directorate of



	<b>ELECTRICAL WORKS (SUPPLY &amp; ERECTION) FOR ALTERNATE POWER SUPPLY ARRANGEMENT OF VIKARMPUR GUEST HOUSE AT TALCHER FERTILIZERS LTD., ANGUL, ODISHA</b>	PC-183/E/ 8001 /S-III	0	
		DOC. NO.	REV	
		Page 39 of 115		

Handicrafts and Handloom or any other body specified by Ministry of Micro, Small and Medium Enterprises with prior consent in writing of the purchasing authority/Engineer-in-charge, the details like Name, Registration No., Address, Contact No. details of material & value of procurement made, etc. of such Enterprises shall be furnished by the successful bidder at the time of submission of invoice/Bill.

- 40.4 The benefit of policy is not extended to the traders/dealers/ Distributors/Stockiest/Wholesalers.
- 40.5 NSIC has initiated a scheme of “Consortia and Tender Marketing Scheme” under which they are assisting the Micro & Small enterprises to market their products and services through tender participation on behalf of the individual unit or through consortia.

Accordingly, if the MSEs or the consortia, on whose behalf the bid is submitted by NSIC, is meeting the BEC and other terms and conditions of tender their bid will be considered for further evaluation. Further, in such cases a declaration is to be submitted by MSE/ consortia on their letter head (s) that all the terms and conditions of tender document shall be acceptable to them.

Further, in such cases a declaration is to be submitted by MSE/ consortia on their letter head (s) that all the terms and conditions of tender document shall be acceptable to them.

#### 41. **AHR ITEMS**

In item rate contract where the quoted rates for the items exceed 50% of the estimate rates, such items will be considered as Abnormally High Rates (AHR) items and payment of AHR items beyond the SOR stipulated quantities shall be made at the lowest amongst the following rates:

- i) Rates as per SOR, quoted by the Contractor/Bidder.
- ii) Rate of the item, which shall be derived as follows:
  - a. Based on rates of Machine and labour as available from the contract (which includes contractor’s supervision, profit, overheads and other expenses).
  - b. In case rates are not available in the contract, rates will be calculated based on prevailing market rates of machine, material and labour plus 15% to cover contractor’s supervision profit, overhead & other expenses.

#### 42. **VENDOR PERFORMANCE EVALUATION**

Shall be as stipulated **Annexure II** to ITB herewith.

#### 43. **INCOME TAX & CORPORATE TAX**

- 43.1 Income tax deduction shall be made from all payments made to the contractor as per the rules and regulations in force and in accordance with the Income Tax Act prevailing from time to time.
- 43.2 Corporate Tax liability, if any, shall be to the contractor’s account.
- 43.3 TDS, wherever applicable shall be deducted as per applicable act/law/rule.

	<b>ELECTRICAL WORKS (SUPPLY &amp; ERECTION) FOR ALTERNATE POWER SUPPLY ARRANGEMENT OF VIKARMPUR GUEST HOUSE AT TALCHER FERTILIZERS LTD., ANGUL, ODISHA</b>	PC-183/E/ 8001 /S-III	0	
		DOC. NO.	REV	
		Page 40 of 115		

43.4 Wherever TDS under GST Laws has been deducted from the invoices raised/ payments made to the vendors, as per the provisions of the GST law/ Rules, Vendors should accept the corresponding GST-TDS amount populated in the relevant screen on GST common portal (www.gst.gov. in).

Further, Vendors should also download the GST TDS certificate from GST common portal (reference path: · Services > User Services >View/Download Certificates option).

**43.5 MENTIONING OF PAN NO. IN INVOICE/BILL**

As per CBDT Notification No. 95/2015 dated 30.12.2015, mentioning of PAN no. is mandatory for procurement of goods/ services/works/consultancy services exceeding Rs. 2 Lacs per transaction.

Accordingly, supplier/ contractor/ service provider/ consultant should mention their PAN no. in their invoice/ bill for any transaction exceeding Rs. 2 lakhs. As provided in the notification, in case supplier/ contractor/ service provider/ consultant do not have PAN no., they have to submit declaration in Form 60 along with invoice/ bill for each transaction.

Payment of supplier/ contractor / service provider/ consultant shall be processed only after fulfillment of above requirement

**44. DISPUTES BETWEEN CPSE'S / GOVERNMENT DEPARTMENT'S / ORGANIZATION**

Subject to conciliation as provided in Clause No. 45, in the event of any dispute (other than those related to taxation matters) or difference relating to the interpretation and application of the provisions of commercial contract(s) between Central Public Sector Enterprises (CPSEs / Port Trusts) inter se and also between CPSEs and Government Departments / Organizations, such dispute or difference shall be taken up by either party for resolution through AMRCD as mentioned in OPE OM No. 4(1)/2013-DPE(GM)/FTS-1835 dated 22-05-2018.

Any party aggrieved with the decision of the Committee at the First level (tier) may prefer an appeal before the Cabinet Secretary at the Second level (tier) within 15 days from the date of receipt of decision of the Committee at First level, through it's administrative Ministry/Department, whose decision will be final and binding on all concerned.

The provisions mentioned at clause no. 44 & 45 shall supersede provisions relating to Conciliation, Arbitration, Governing Law & Jurisdiction and Disputes between CPSE's/ Government Department's/ Organizations mentioned in General Conditions of Contract (GCC) and elsewhere in tender document.

**45. DISPUTE RESOLUTION MECHANISM**

**1.0 CONCILIATION**

Where invitation for Conciliation has been accepted by the other party, the Parties shall attempt to settle such dispute(s) amicably under Part-III of the Arbitration and Conciliation Act, 1996. It would be only after exhausting the option of Conciliation as an Alternate Dispute Resolution Mechanism that the Parties hereto shall invoke Arbitration Clause. For the purpose of this clause, the option of 'Conciliation' shall be deemed to have been exhausted, even in case of rejection of 'Conciliation' by any of the Parties.

	<b>ELECTRICAL WORKS (SUPPLY &amp; ERECTION) FOR ALTERNATE POWER SUPPLY ARRANGEMENT OF VIKARMPUR GUEST HOUSE AT TALCHER FERTILIZERS LTD., ANGUL, ODISHA</b>	PC-183/E/ 8001 /S-III	0	
		DOC. NO.	REV	
		Page 41 of 115		

## 2.0 ARBITRATION

All issue(s)/dispute(s) excluding the matters that have been specified as excepted matters and listed at clause no. 2.6 and which cannot be resolved through Conciliation, such issue(s)/dispute(s) shall be referred to arbitration for adjudication by Sole Arbitrator. The party invoking the Arbitration shall have the option to either opt for Ad-hoc Arbitration as provided at Clause 2.1 below or Institutionalized Arbitration as provided at Clause 2.2 below, the remaining clauses from 2.3 to 2.7 shall apply to both Ad-hoc and Institutional Arbitration:-

- 2.1 On invocation of the Arbitration clause by either party, TFL shall suggest a panel of three independent and distinguished persons (Retd Supreme Court & High Court Judges only) to the other party from the Panel of Arbitrators maintained by 'Delhi International Arbitration Centre (DIAC) to select any one among them to act as the Sole Arbitrator. In the event of failure of the other party to select the Sole Arbitrator within 30 days from the receipt of the communication from TFL suggesting the panel of arbitrators, the right of selection of the sole arbitrator by the other party shall stand forfeited and TFL shall appoint the Sole Arbitrator from the suggested panel of three Arbitrators for adjudication of dispute(s). The decision of TFL on the appointment of the sole arbitrator shall be final and binding on the other party. The fees payable to Sole Arbitrator shall be governed by the fee Schedule of "Delhi International Arbitration Centre".

OR

- 2.2 If a dispute arises out of or in connection with this contract, the party invoking the Arbitration shall submit that dispute to any one of the Arbitral Institutions i.e ICADR/ICA/DIAC/SFCA and that dispute shall be adjudicated in accordance with their respective Arbitration Rules. The matter shall be adjudicated by a Sole Arbitrator who shall necessarily be a Retd. Supreme Court/High Court Judge to be appointed/nominated by the respective institution. The cost/expenses pertaining to the said Arbitration shall also be governed in accordance with the Rules of the respective Arbitral Institution. The decision of the party invoking the Arbitration for reference of dispute to a specific Arbitral institution for adjudication of that dispute shall be final and binding on both the parties and shall not be subject to any change thereafter. The institution once selected at the time of invocation of dispute shall remain unchanged.
- 2.3 The cost of arbitration proceedings shall be shared equally by the parties.
- 2.4 The Arbitration proceedings shall be in English language and the seat, venue and place of Arbitration shall be New Delhi, India only.
- 2.5 Subject to the above, the provisions of Arbitration & Conciliation Act 1996 and any amendment thereof shall be applicable. All matter relating to this Contract and arising out of invocation of Arbitration clause are subject to the exclusive jurisdiction of the Court(s) situated at New Delhi.
- 2.6 List of Excepted matters:
- a) Dispute(s)/issue(s) involving claims below Rs 25 lakhs and above Rs 25 crores.

	<b>ELECTRICAL WORKS (SUPPLY &amp; ERECTION) FOR ALTERNATE POWER SUPPLY ARRANGEMENT OF VIKARMPUR GUEST HOUSE AT TALCHER FERTILIZERS LTD., ANGUL, ODISHA</b>	PC-183/E/ 8001 /S-III	0	
		DOC. NO.	REV	
		Page 42 of 115		

- b) Dispute(s)/issue(s) relating to indulgence of Contractor/Vendor/Bidder in corrupt/fraudulent/collusive/coercive practices and/or the same is under investigation by CBI or Vigilance or any other investigating agency or Government.
- c) Dispute(s)/issue(s) wherein the decision of Engineer-In-Charge/owner/ TFL has been made final and binding in terms of the Contract.

2.7. Disputes involving claims below Rs 25 Lakhs and above Rs. 25 crores:- Parties mutually agree that dispute(s)/issue(s) involving claims below Rs 25 Lakhs and above Rs 25 crores shall not be subject matter of Arbitration and are subject to the exclusive jurisdiction of the Court(s) situated at New Delhi.

3.0 **GOVERNING LAW AND JURISDICTION:**

The Contract shall be governed by and construed in accordance with the laws in force in India. The Parties hereby submit to the exclusive jurisdiction of the Courts situated at New Delhi for adjudication of disputes, injunctive reliefs, actions and proceedings, if any, arising out of this Contract.

**46. INAM-PRO (PLATFORM FOR INFRASTRUCTURE AND MATERIALS PROVIDERS)**

INAM-Pro (Platform for infrastructure and materials providers) is a web based platform for infrastructure provides and materials suppliers and was developed by Ministry of Road Transport and Highways (MoRT&H) with a view to reduce project execution delays on account of supply shortages and inspire greater confidence in contractors to procure cement to start with directly from the manufacturers.

Presently, numerous cement companies are registered in the portal and offering cement for sale on the portal with a commitment period of 3 years. These companies have bound themselves by ceiling rates for the entire commitment period, wherein they are allowed to reduce or increase their cement rates any number of times within the ceiling rate, but are not permitted to exceed the said ceiling rate.

MoRT&H is expanding the reach of this web-portal by increasing both the product width as well as the product depth. They are working on incorporating 60 plus product categories. The product range will span from large machineries like Earth Movers and Concrete Mixers, to even the smallest items like road studs. MoRT&H intend to turn it into a portal which services every infrastructure development related need of a modern contractor.

OWNER's contractors may use this innovative platform, wherever applicable. The usage of web – Portal is a completely voluntary exercise. The platform, however, can serve as a benchmark for comparison of offered prices and products.

**47. PROMOTION OF PAYMENT THROUGH CARDS AND DIGITAL MEANS**

To promote cashless transactions, the onward payments by Contractors to their employees, service providers, sub-contractors and suppliers may be made through Cards and Digital means to the extent possible

	<b>ELECTRICAL WORKS (SUPPLY &amp; ERECTION) FOR ALTERNATE POWER SUPPLY ARRANGEMENT OF VIKARMPUR GUEST HOUSE AT TALCHER FERTILIZERS LTD., ANGUL, ODISHA</b>	PC-183/E/ 8001 /S-III	0	
		DOC. NO.	REV	
		Page 43 of 115		

**48. CONTRACTOR TO ENGAGE CONTRACT MANPOWER BELONGING TO SCHEDULED CASTES AND WEAKER SECTIONS OF THE SOCIETY**

While engaging the contractual manpower, Contractors are required to make efforts to provide opportunity of employment to the people belonging to Scheduled Castes and weaker sections of the society also in order to have a fair representation of these sections.

**49. QUARTERLY CLOSURE OF THE CONTRACT [FOR APPLICABILITY OF THIS CLAUSE REFER BDS]:-**

During execution of contracts/orders, various issues may arise. In order to timely detect and to address the contractual issue (s) during the execution of contracts, OWNER has introduced a mechanism of quarterly closure of the contract, under which all the issues related to the contract execution will be monitored on quarterly basis for resolution.

Vendors/Contractors are required to co-operate with EIC for proper implementation of this mechanism for smooth execution of the contract.

**50. PROVISIONS FOR STARTUPS (AS DEFINED IN GAZETTENOTIFICATION NO. D.L-33004/99 DATED 18.02.2016 AND 23.05.2017 OF MINISTRY OF COMMERCE AND INDUSTRY AND AS AMENDED FROM TIME TO TIME) [FOR APPLICABILITY REFER BDS]**

As mentioned in Section-II, Technical BEC and Financial BEC shall not be applicable for Start-ups.

Prior experience and Prior turnover criteria as mentioned in Clause No. 1.1 & 2.1 above shall not be applicable for start-ups[whether Micro & Small Enterprises (MSEs) or otherwise] subject to their meeting the quality and technical specifications specified in tender document. However, the start-ups have to meet BEC as mentioned in Clause No. 1.2, 2.2 & 2.3 on their own.

For availing the relaxation, bidder is required to submit requisite certificate towards Startup enterprise registration issued by Department for Promotion of Industry and Internal Trade (DPIIT), Ministry of Commerce & Industry specifying the goods/ job domain wherein they are registered for. In case the certificate of DPIIT towards recognition does not specify the goods/ job domain, startups are required to submit the documents for the same including the application submitted to DPIIT. Further, above document should also be certified by the Chartered Accountant (not being an employee or a Director or not having any interest in the bidder's company/firm) and notary public with legible stamp

Further, above document should also be certified by the Chartered Accountant (not being an employee or a Director or not having any interest in the bidder's company/firm) and notary public with legible stamp.

If a Startup emerge lowest bidder, the LoA on such Startup shall be placed for entire tendered quantity/group/item/part (as the case may be). However, during the Kick of Meeting monthly milestones/ check points would be drawn. Further, the performance of such contractor/ service provider will be reviewed more carefully and action to be taken as per provision of contract in case of failure/ poor performance.

	<b>ELECTRICAL WORKS (SUPPLY &amp; ERECTION) FOR ALTERNATE POWER SUPPLY ARRANGEMENT OF VIKARPUR GUEST HOUSE AT TALCHER FERTILIZERS LTD., ANGUL, ODISHA</b>	PC-183/E/ 8001 /S-III	0	
		DOC. NO.	REV	
		Page 44 of 115		

**51. PROVISION REGARDING INVOICE FOR REDUCED VALUE OR CREDIT NOTE TOWARDS PRS**

As mentioned in GCC, PRS is the reduction in the consideration / contract value for the goods / services covered under this contract. In case of delay in execution of contract, contractor should raise Tax invoice for reduced value as per Price Reduction Schedule Clause (PRS clause). If contractor has raised the Tax invoice for full value, then contractor should issue Credit Note towards the applicable PRS amount with applicable taxes.

In such cases if contractor fails to submit the Tax invoice with reduced value or does not issue credit note as mentioned above, Owner will release the payment to contractor after giving effect of the PRS clause with corresponding reduction of taxes charged on vendor's Tax invoice, to avoid delay in delivery/ collection of material.

In case any financial implication arises on Owner due to issuance of Tax invoice without reduction in price or non-issuance of Credit Note, the same shall be to the account of contractor. Owner shall be entitled to deduct/ setoff/ recover such GST amount (CGST & SGST/ UTGST or IGST) together with penalties and interest, if any, against any amounts paid or becomes payable by Owner in future to the Contractor under this contract or under any other contract.

**52. PROVISION REGARDING REVERSE AUCTION \*\***

**\*\* (This Clause is NOT APPLICABLE for this NIT)**

~~On line reverse auction shall be applicable for this tender. Accordingly, the decision to conduct reverse auction shall be communicated to shortlisted bidders prior to opening of price bid.~~

~~TFL shall finalize tender after conducting reverse auction except in those cases where less than four techno commercially acceptable offers are available. In case, after techno commercial evaluation in a tender, number of technically & commercially acceptable offers are less than 04 (four) then no reverse auction will be conducted (but the TFL/PDIL shall take appropriate decision regarding conducting offline price negotiation, if required).~~

~~Accordingly, the decision to conduct reverse auction shall be communicated to shortlisted bidders prior to opening of price bid.~~

**53. UNIQUE DOCUMENT IDENTIFICATION NUMBER BY PRACTICING CHARTERED ACCOUNTANTS**

Practicing Chartered Accountants shall generate Unique Document Identification Number (UDIN) for all certificates issued by them as per provisions of Tender Document.

However, UDIN may not be required for documents being attested by Chartered Accountants in terms of provisions of Tender Document.

**54. CLAUSE REGARDING PROVISION FOR PROCUREMENT FROM A BIDDER WHICH SHARES A LAND BORDER WITH INDIA**

- i. Order (Public Procurement No. 1) dated 23.07.2020, Order (Public Procurement No. 2) dated 23.07.2020 and Order (Public Procurement No. 3) dated 24.07.2020, Department



	<b>ELECTRICAL WORKS (SUPPLY &amp; ERECTION) FOR ALTERNATE POWER SUPPLY ARRANGEMENT OF VIKARMPUR GUEST HOUSE AT TALCHER FERTILIZERS LTD., ANGUL, ODISHA</b>	PC-183/E/ 8001 /S-III	0	
		DOC. NO.	REV	
		Page 45 of 115		

of Expenditure, Ministry of Finance, Govt. of India refers. The same are available at website <https://doe.gov.in/procurement-policy-divisions>.

- ii. Any bidder from a country which shares a land border with India will be eligible to bid in this tender only if the bidder is registered with the Competent Authority. For details of competent authority refer to Annexure I of Order (Public Procurement No. 1) dated 23.07.2020.

Further the above will not apply to bidders from those countries (even if sharing a land border with India) to which the Government of India has extended lines of creditor in which the Government of India is engaged in development projects. Updated lists of countries to which lines of credit have been extended or in which development projects are undertaken are given in the website of the Ministry of External Affairs, Govt. of India

- iii. **"Bidder"** (including the term 'tenderer', 'consultant' 'vendor' or 'service provider' in certain contexts) **for purpose of this provision** means any person or firm or company, including any member of a consortium or joint venture (that is an association of several persons, or firms or companies), every artificial juridical person not falling in any of the descriptions of bidders stated hereinbefore, including any agency, branch or office controlled by such person, participating in a procurement process.
- iv. **"Bidder from a country which shares a land border with India"** for the purpose of this:
  - a. An entity incorporated, established or registered in such a country; or
  - b. A subsidiary of an entity incorporated, established or registered in such a country; or
  - c. An entity substantially controlled through entities incorporated, established or registered in such a country; or
  - d. An entity whose beneficial owner is situated in such a country; or
  - e. An Indian (or other) agent of such an entity; or
  - f. A natural person who is a citizen of such a country; or
  - g. A consortium or joint venture where any member of the consortium or joint venture falls under any of the above
- v. **"Beneficial owner"** for the purpose of above (iv) will be as under:
  - a. In case of a company or Limited Liability Partnership, the beneficial owner is the natural person(s), who, whether acting alone or together, or through one or more juridical person(s), has a controlling ownership interest or who exercises control through other means.  
Explanation—
    - i) "Controlling ownership interest" means ownership of, or entitlement to, more than twenty-five per cent of shares or capital or profits of the company;
    - ii) "Control" shall include the right to appoint the majority of the directors or to control the management or policy decisions, including by virtue of their shareholding or management rights or shareholders agreements or voting agreements;

	<b>ELECTRICAL WORKS (SUPPLY &amp; ERECTION) FOR ALTERNATE POWER SUPPLY ARRANGEMENT OF VIKARMPUR GUEST HOUSE AT TALCHER FERTILIZERS LTD., ANGUL, ODISHA</b>	PC-183/E/ 8001 /S-III	0	
		DOC. NO.	REV	
		Page 46 of 115		

- b. In case of a partnership firm, the beneficial owner is the natural person(s) who, whether acting alone or together, or through one or more juridical person, has ownership of entitlement to more than fifteen percent of capital or profits of the partnership;
- c. In case of an unincorporated association or body of individuals, the beneficial owner is the natural person(s), who, whether acting alone or together, or through one or more juridical person, has ownership of or entitlement to more than fifteen percent of the property or capital or profits of such association or body of individuals;
- d. Where no natural person is identified under (a) or (b) or (c) above, the beneficial owner is the relevant natural person who holds the position of senior managing official;
- e. In case of a trust, the identification of beneficial owner(s) shall include identification of the author of the trust, the trustee, the beneficiaries with fifteen percent or more interest in the trust and any other natural person exercising ultimate effective control over the trust through a chain of control or ownership.
- vi. **"Agent"** for the purpose of this Order is a person employed to do any act for another, or to represent another in dealings with third persons
- vii. **SUBMISSION OF CERTIFICATE IN BIDS:**  
Bidder shall submit a certificate in this regard as Form **F-20**. If such certificate given by a bidder whose bid is accepted is found to be false, this would be a ground for immediate rejection of the bid/termination and further action as per "Procedure for Action in case of Corrupt/Fraudulent/ Collusive / Coercive Practices" of tender document.
- viii. **SUBMISSION OF CERTIFICATE IN BIDS:**  
The registration, wherever applicable, should be valid at the time of submission of bids and at the time of acceptance of bids. In respect of supply otherwise than by tender, registration should be valid at the time of placement of order. If the bidder was validly registered at the time of acceptance / placement of order, registration shall not be a relevant consideration during contract execution.
- ix. The successful bidder shall not be allowed to sub-contract works to any contractor from a country which shares a land border with India unless such contractor is registered with the Competent Authority. The definition of "contractor from a country which shares a land border with India" shall be as in Para (iv) herein above. A Certificate to this regard is to be submitted by bidder is placed at Form **F-21**.



	<b>ELECTRICAL WORKS (SUPPLY &amp; ERECTION) FOR ALTERNATE POWER SUPPLY ARRANGEMENT OF VIKARMPUR GUEST HOUSE AT TALCHER FERTILIZERS LTD., ANGUL, ODISHA</b>	PC-183/E/ 8001 /S-III	0	
		DOC. NO.	REV	
		Page 47 of 115		

**[G] – ANNEXURES**

	<b>ELECTRICAL WORKS (SUPPLY &amp; ERECTION) FOR ALTERNATE POWER SUPPLY ARRANGEMENT OF VIKARPUR GUEST HOUSE AT TALCHER FERTILIZERS LTD., ANGUL, ODISHA</b>	PC-183/E/ 8001 /S-III	0	
		DOC. NO.	REV	
		Page 48 of 115		

**Annexure-I**

**PROCEDURE FOR ACTION IN  
CASE CORRUPT/FRAUDULENT/COLLUSIVE/COERCIVE  
PRACTICES**

**A Definitions:**

A.1 “Corrupt Practice” means the offering, giving, receiving or soliciting, directly or indirectly, anything of value to improperly influence the actions in selection process or in contract execution.

“Corrupt Practice” also includes any omission for misrepresentation that may mislead or attempt to mislead so that financial or other benefit may be obtained or an obligation avoided.

A2 “Fraudulent Practice” means and include any act or omission committed by a agency or with his connivance or by his agent by misrepresenting/ submitting false documents and/ or false information or concealment of facts or to deceive in order to influence a selection process or during execution of contract/order.

A3 “Collusive Practice amongst bidders (prior to or after bid submission)” means a scheme or arrangement designed to establish bid prices at artificial non-competitive levels and to deprive the Employer of the benefits of free and open competition.

A.4 “Coercive practice” means impairing or harming or threatening to impair or harm directly or indirectly, any agency or its property to influence the improperly actions of an agency, obstruction of any investigation or auditing of a procurement process.

A.5 “Vendor/Supplier/Contractor/Consultant/Bidder” is herein after referred as “Agency”

A.6 “Appellate Authority” shall mean Committee of Directors consisting of Director (Finance) and Director (BD) for works centers under Director (Projects). For all other cases committee of Directors shall consist of Director (Finance) & Director(Projects).

A.7 “Competent Authority” shall mean the authority, who is competent to take final decision for Suspension of business dealing with an Agency/ (ies) and Banning of business dealings with Agency/ (ies) and shall be the “Director” concerned.

A.8 “Allied Agency” shall mean all the concerns within the sphere of effective influence of banned/ suspended agencies. In determining this, the following factors may be taken into consideration:

- (a) Whether the management is common;
- (b) Majority interest in the management is held by the partners or directors of banned/ suspended firm.
- (c) substantial or majority shares are owned by banned/ suspended agency and by virtue of this it has a controlling voice.

A.9 “Investigating Agency” shall mean any department or unit of TFL investigating into the conduct of Agency/ party and shall include the Vigilance Department of the TFL,

	<b>ELECTRICAL WORKS (SUPPLY &amp; ERECTION) FOR ALTERNATE POWER SUPPLY ARRANGEMENT OF VIKARMPUR GUEST HOUSE AT TALCHER FERTILIZERS LTD., ANGUL, ODISHA</b>	PC-183/E/ 8001 /S-III	0	
		DOC. NO.	REV	
		Page 49 of 115		

Central Bureau of Investigation, State Police or any other agency set up by the Central or state government having power to investigate.

**B Actions against bidder(s) indulging in corrupt /fraudulent/ collusive/ coercive practice**

**B.1 Irregularities noticed during the evaluation of the bids:**

If it is observed during bidding process/ bids evaluation stage that a bidder has indulged in corrupt/fraudulent /collusive/coercive practice, the bid of such Bidder (s) shall be rejected and its Earnest Money Deposit (EMD) shall be forfeited.

Further, such agency shall be banned for future business with TFL for a period specified in para B 2.2 below from the date of issue of banning order.

**B.2 Irregularities noticed after award of contract**

**(i) During execution of contract:**

If an agency, is found to have indulged in corrupt/fraudulent/ collusive /coercive practices, action shall be initiated as per procedure mentioned at Clause no. E for putting the agency on banning list.

After conclusion of process and issuance of Speaking order for putting party on banning list as per process defined in para E, the order (s)/ contract (s) where it is concluded that such irregularities have been committed shall be terminated and Contract cum Performance Bank Guarantee (CPBG) submitted by agency against such order (s)/ contract (s) shall also be forfeited. Further such order/ contract will be closed following the due procedure in this regard.

The amount that may have become due to the contractor on account of work already executed by him shall be payable to the contractor and this amount shall be subject to adjustment against any amounts due from the contractor under the terms of the contract. No risk and cost provision will be enforced in such cases.

**Suspension of order/ contract:**

Further, only in the following situations, the concerned order (s)/ contract(s) (where Corrupt/Fraudulent/ Collusive/ Coercive Practices are observed) and payment shall be suspended after issuance of Suspension cum Show Cause Notice:

- (i) Head of Corporate Vigilance Department/CVO based on the investigation by them, recommend for specific immediate action against the agency.
- (ii) Head of Corporate Vigilance Department/CVO based on the input from investigating agency, forward for specific immediate action against the agency.

	<b>ELECTRICAL WORKS (SUPPLY &amp; ERECTION) FOR ALTERNATE POWER SUPPLY ARRANGEMENT OF VIKARPUR GUEST HOUSE AT TALCHER FERTILIZERS LTD., ANGUL, ODISHA</b>	PC-183/E/ 8001 /S-III	0	
		DOC. NO.	REV	
		Page 50 of 115		

Suspension cum Show Cause Notice being issued in above cases after approval of the competent authority (as per provisions mentioned under Clause no. D) shall also include the provision for suspension of Order (s)/ Contract (s) and payment. Accordingly, after issuance of Suspension cum Show Cause Notice by Corporate C&P Department, the formal communication for suspension of Order (s)/ Contract (s) and payment with immediate effect will be issued by the following with copy to concerned F&A:

- (i) For Projects cases: concerned Project Managers in case of Purchase Orders and concerned Construction-in Charge (where PMC is EIC)/ Engineer-in-Charge (EIC) in case of Contracts
- (ii) For other than Projects cases: concerned Dealing officer in case of Purchase Orders and concerned Engineer-in-Charge (EIC) in case of Contracts.

During suspension, Contractor/ Service Providers will be allowed to visit the plant/ site for upkeep of their items/ equipment, TFL's issued materials (in case custody of same is not taken over), demobilizing the site on confirmation of EIC, etc.

However, no suspension of contract/ order will be initiated in Exceptional Cases mentioned at Clause no. B.2.3.

**(ii) After execution of contract and during Defect liability period (DLP)/ Warranty/Guarantee Period:**

If an agency is found to have indulged in corrupt/fraudulent/ collusive/coercive practices, after execution of contract and during DLP/ Warranty/Guarantee Period, the agency shall be banned for future business with TFL for a period specified in para B 2.2 below from the date of issue of banning order.

Further, the Contract cum Performance Bank Guarantee (CPBG)/Contract Performance Security (CPS) submitted by agency against such order (s)/ contract (s) shall be forfeited.

**(iii) After expiry of Defect liability period (DLP)/ Warranty/Guarantee Period**

If an agency is found to have indulged in corrupt/fraudulent/ collusive/coercive practices, after expiry of Defect liability period (DLP)/ Warranty/Guarantee Period, the agency shall be banned for future business with TFL for a period specified in para B 2.2 below from the date of issue of banning order.

**B.2.2 Period of Banning**

The period of banning of agencies indulged in Corrupt/ Fraudulent/ Collusive/Coercive Practices shall be as under and to be reckoned from the date of banning order:

	<b>ELECTRICAL WORKS (SUPPLY &amp; ERECTION) FOR ALTERNATE POWER SUPPLY ARRANGEMENT OF VIKARMPUR GUEST HOUSE AT TALCHER FERTILIZERS LTD., ANGUL, ODISHA</b>	PC-183/E/ 8001 /S-III	0	
		DOC. NO.	REV	
		Page 51 of 115		

S. No.	Description	Period of banning from the date of issuance of Banning order
1	<p>Misrepresentation/False information other than pertaining to BEC of tender but having impact on the selection process.</p> <p>For example, if an agency confirms not being in holiday in TFL/PSU's PMC or banned by PSUs/ Govt. Dept., liquidation, bankruptcy &amp; etc. and subsequently it is found otherwise, such acts shall be considered in this category.</p>	02 years
2	Corrupt/Fraudulent (pertaining to BEC of tender) /Collusive/Coercive Practices	03 years
2.1	<p>If an agency again commits Corrupt/Fraudulent (pertaining to BEC of tender) /Collusive/ Coercive Practices in subsequent cases after their banning, such situation of repeated offense to be dealt with more severity and following shall be the period of banning:</p> <p>(i) Repeated once</p> <p>(ii) Repeated twice or more</p>	<p>7 years (in addition to the period already served)</p> <p>15 years (in addition to the period already served)</p>
3	Indulged in unauthorized disposal of materials provided by TFL	7 years
4	If act of vendor/ contractor is a threat to the National Security	15 years

	<b>ELECTRICAL WORKS (SUPPLY &amp; ERECTION) FOR ALTERNATE POWER SUPPLY ARRANGEMENT OF VIKARMPUR GUEST HOUSE AT TALCHER FERTILIZERS LTD., ANGUL, ODISHA</b>	PC-183/E/ 8001 /S-III	0	
		DOC. NO.	REV	
		Page 52 of 115		

**C Effect of banning on other ongoing contracts/tenders**

- C.1 If an agency is put on Banning, such agency should not be considered in ongoing tenders/future tenders.
- C.2 However, if such an agency is already executing other order (s)/ contract (s) where no corrupt/fraudulent/ collusive/coercive practice is found, the agency should be allowed to continue till its completion without any further increase in scope except those incidental to original scope mentioned in the contract.
- C.3 If an agency is put on the Banning List during tendering and no irregularity is found in the case under process:
- C.3.1 after issue of the enquiry /bid/tender but before opening of Technical bid, the bid submitted by the agency shall be ignored.
- C.3.2 after opening Technical bid but before opening the Price bid, the Price bid of the agency shall not be opened and BG/EMD submitted by the agency shall be returned to the agency.
- C.3.3 after opening of price, BG/EMD made by the agency shall be returned; the offer of the agency shall be ignored & will not be further evaluated. If the agency is put on banning list for fraud/ mis-appropriation of facts committed in the same tender/other tender where errant agency emerges as the lowest (L1), then such tender shall also be cancelled and re-invited.

**D. Procedure for Suspension of Bidder**

**D.1 Initiation of Suspension**

Action for suspension business dealing with any agency/(ies) shall be initiated by Corporate C&P Department when

- (i) Corporate Vigilance Department based on the fact of the case gathered during investigation by them recommend for specific immediate action against the agency.
- (ii) Corporate Vigilance Department based on the input from Investigating agency, forward for specific immediate action against the agency.
- (iii) Non performance of Vendor/Supplier/Contractor/Consultant leading to termination of Contract/Order.

**D.2 Suspension Procedure:**

- D.2.1 The order of suspension would operate initially for a period not more than six months and is to be communicated to the agency and also to Corporate Vigilance Department. Period of suspension can be extended with the approval of the Competent Authority by one month at a time with a ceiling of six months pending a conclusive decision to put the agency on banning list.

	<b>ELECTRICAL WORKS (SUPPLY &amp; ERECTION) FOR ALTERNATE POWER SUPPLY ARRANGEMENT OF VIKARMPUR GUEST HOUSE AT TALCHER FERTILIZERS LTD., ANGUL, ODISHA</b>	PC-183/E/ 8001 /S-III	0	
		DOC. NO.	REV	
		Page 53 of 115		

- D.2.2 During the period of suspension, no new business dealing may be held with the agency.
- D.2.3 Period of suspension shall be accounted for in the final order passed for banning of business with the agency.
- D.2.4 The decision regarding suspension of business dealings should also be communicated to the agency.
- D.2.5 If a prima-facie, case is made out that the agency is guilty on the grounds which can result in banning of business dealings, proposal for issuance of suspension order and show cause notice shall be put up to the Competent Authority. The suspension order and show cause notice must include that (i) the agency is put on suspension list and (ii) why action should not be taken for banning the agency for future business from TFL.

The competent authority to approve the suspension will be same as that for according approval for banning.

**D 3 Effect of Suspension of business:**

Effect of suspension on other on-going/future tenders will be as under:

- D.3.1 No enquiry/bid/tender shall be entertained from an agency as long as the name of agency appears in the Suspension List.
- D.3.2 If an agency is put on the Suspension List during tendering:
- D.3.2.1 after issue of the enquiry /bid/tender but before opening of Technical bid, the bid submitted by the agency shall be ignored.
- D.3.2.2 after opening Technical bid but before opening the Price bid, the Price bid of the agency shall not be opened and BG/EMD submitted by the agency shall be returned to the agency.
- D.3.2.3 after opening of price, BG/EMD made by the agency shall be returned; the offer of the agency shall be ignored & will not be further evaluated. If the agency is put on Suspension list for fraud/ mis-appropriation of facts conducted in the same tender/other tender where errant agency emerges as the lowest (L1), then such tender shall also be cancelled and re-invited.
- D.3.3 The existing contract (s)/ order (s) under execution shall continue.
- D.3.4 Tenders invited for procurement of goods, works and services shall have provision that the bidder shall submit a undertaking to the effect that (i) neither the bidder themselves nor their allied agency/(ies) are on banning list of TFL and (ii) bidder is not banned by any Government department/ Public Sector.

	<b>ELECTRICAL WORKS (SUPPLY &amp; ERECTION) FOR ALTERNATE POWER SUPPLY ARRANGEMENT OF VIKARMPUR GUEST HOUSE AT TALCHER FERTILIZERS LTD., ANGUL, ODISHA</b>	PC-183/E/ 8001 /S-III	0	
		DOC. NO.	REV	
		Page - 54 - of 120		

**F. Appeal against the Decision of the Competent Authority:**

- F.1 The agency may file an appeal against the order of the Competent Authority for putting the agency on banning list. The appeal shall be filed to Appellate Authority. Such an appeal shall be preferred within one month from the of receipt of banning order.
- F.2 Appellate Authority would consider the appeal and pass appropriate order which shall be communicated to the party as well as the Competent Authority.
- F.3 Appeal process may be completed within 45 days of filing of appeal with the Appellate Authority.
- G.** Wherever there is contradiction with respect to terms of „Integrity pact“, GCC and „Procedure for action in case of Corrupt/Fraudulent/ Collusive/Coercive Practice“, the provisions of „Procedure for action in case of Corrupt/Fraudulent/ Collusive/Coercive Practice“ shall prevail.
-



	<b>ELECTRICAL WORKS (SUPPLY &amp; ERECTION) FOR ALTERNATE POWER SUPPLY ARRANGEMENT OF VIKARMPUR GUEST HOUSE AT TALCHER FERTILIZERS LTD., ANGUL, ODISHA</b>	PC-183/E/ 8001 /S-III	0	
		DOC. NO.	REV	
		Page - 55 - of 115		

## Annexure-II

### PROCEDURE FOR EVALUATION OF PERFORMANCE OF VENDORS/ SUPPLIERS/ CONTRACTORS/ CONSULTANTS

#### 1.0 GENERAL

A system for evaluation of Vendors/ Suppliers/Contractors/ Consultants and their performance is a key process and important to support an effective purchasing & contracting function of an organization.

Performance of all participating Vendors/ Suppliers/Contractors/ Consultants need to be closely monitored to ensure timely receipt of supplies from a Vendor, completion of an assignment by a Consultant or complete execution of order by a contractor within scheduled completion period. For timely execution of projects and meeting the operation & maintenance requirement of operating plants, it is necessary to monitor the execution of order or contracts right from the award stage to completion stage and take corrective measures in time.

#### 2.0 OBJECTIVE

The objective of Evaluation of Performance aims to recognize, and develop reliable Vendors/ Suppliers/Contractors/ Consultants so that they consistently meet or exceed expectations and requirements.

The purpose of this procedure is to put in place a system to monitor performance of Vendors/ Suppliers/Contractors/ Consultants associated with TFL so as to ensure timely completion of various projects, timely receipt of supplies including completion of works & services for operation and maintenance of operating plants and quality standards in all respects.

#### 3.0 METHODOLOGY

##### i) Preparation of Performance Rating Data Sheet

Performance rating data Sheet for each and every Vendor/ Supplier/Contractor/Consultant for all orders/Contracts with a value of Rs. 50 Lakhs and above is recommended to be drawn up. Further, Performance rating data Sheet for orders/contracts of Vendor/Supplier/Contractor/ Consultant who are on watch list/holiday list/ banning list shall be prepared irrespective of order/ contract value. These data sheets are to be separately prepared for orders/ contracts related to Projects and O&M. Format, Parameters, Process, responsibility for preparation of Performance Rating Data Sheet are separately mentioned.

##### ii) Measurement of Performance

Based on the parameters defined in Data Sheet, Performance of concerned Vendor/ Supplier/Contractor/ Consultant would be computed and graded accordingly. The measurement of the performance of the Party would be its ability to achieve the minimum scoring of 60% points in the given parameters.

	<b>ELECTRICAL WORKS (SUPPLY &amp; ERECTION) FOR ALTERNATE POWER SUPPLY ARRANGEMENT OF VIKARMPUR GUEST HOUSE AT TALCHER FERTILIZERS LTD., ANGUL, ODISHA</b>	PC-183/E/ 8001 /S-III	0	
		DOC. NO.	REV	
		Page - 56 - of 115		

iii) Initiation of Measures:

Depending upon the Grading of Performance, corrective measures would be initiated by taking up the matter with concerned Vendor/ Supplier/Contractor/ Consultant. Response of Vendor/ Supplier/Contractor/ Consultant would be considered before deciding further course of action.

iv) Implementation of Corrective Measures:

Based on the response of Vendor/ Supplier/Contractor/ Consultant, concerned Engineer-in-Charge for the Projects and/or OIC in case of O&M would recommend for continuation or discontinuation of such party from the business of TFL.

v) Orders/contracts placed on Proprietary/OEM basis for O&M will be evaluated and, if required, corrective action will be taken for improvement in future.

4.0 **EXCLUSIONS:**

The following would be excluded from the scope of evaluation of performance of Vendors/ Suppliers/Contractors/ Consultants :

- i) Orders/Contracts below the value of Rs. 50 Lakhs if Vendor/ Supplier/Contractor/ Consultant is not on watch list/ holiday list/ banning list.
- ii) Orders for Misc./Administrative items/ Non stock Non valued items.

However, concerned Engineer-in-Charge /OICs will continue to monitor such cases so as to minimize the impact on Projects/O&M plants due to non-performance of Vendors/ Suppliers/Contractors/ Consultants in all such cases.

5.0 **PROCESS OF EVALUATION OF PERFORMANCE OF VENDORS/ SUPPLIERS/ CONTRACTORS/ CONSULTANTS**

5.1 FOR PROJECTS

- i) Evaluation of performance of Vendors/ Suppliers/Contractors/ Consultants in case of PROJECTS shall be done immediately with commissioning of any Project.
- ii) On commissioning of any Project, EIC (Engineer-in-charge)/ Project-in-charge shall prepare a Performance Rating Data Sheet (Format at Annexure-1) for all Orders and Contracts.
- iii) Depending upon the Performance Rating, following action shall be initiated by Engineer-in-charge/Project-in-charge:

Sl.No.	Performance Rating	Action
1	POOR	Seek explanation for Poor performance
2	FAIR	Seek explanation for Fair performance
3	GOOD	Letter to the concerned for improving

	<b>ELECTRICAL WORKS (SUPPLY &amp; ERECTION) FOR ALTERNATE POWER SUPPLY ARRANGEMENT OF VIKARMPUR GUEST HOUSE AT TALCHER FERTILIZERS LTD., ANGUL, ODISHA</b>	PC-183/E/ 8001 /S-III	0	
		DOC. NO.	REV	
		Page - 57 - of 115		

		performance in future
4	VERY GOOD	No further action

iv) Reply from concerned Vendor/ Supplier/Contractor/ Consultant shall be examined. In case of satisfactory reply, Performance Rating data Sheet to be closed with a letter to the concerned for improving performance in future.

v) When no reply is received or reasons indicated are unsatisfactory, the following actions need to be taken:

A) Where performance rating is "POOR" (as per Performance Rating carried out after execution of Order/ Contract and where no reply/ unsatisfactory reply is received from party against the letter seeking the explanation from Vendor/Supplier/Contractor/ Consultant along with sharing the performance rating)

Recommend such defaulting Vendor/Supplier/Contractor/ Consultant for the following action:

(a) **First such instance: Advisory notice (Yellow Card)** shall be issued and Vendor/Supplier/Contractor/ Consultant shall be put on watch list for a period of Three (3) Years. Such vendor will be allowed to participate in all other tenders and to execute other ongoing order/ contract (s) or new contract/ order (s).

The Yellow card will be automatically revoked after a period of three years unless the same is converted into Red Card due to subsequence instances of poor/ non-performance in other ongoing order (s)/ contract (s) or new order (s) /contact (s) on such Vendor/ Supplier/ Contractor/ Consultant.

(b) **Second such instance in other ongoing order (s)/ contract (s) or new order (s) /contact (s) on such Vendor/ Supplier/ Contractor/ Consultant**

(i) Poor Performance due to reasons other than Quality: **Putting on Holiday for a period of One Year**

(ii) Poor Performance on account of Quality (if any mark obtained against Quality parameter is less than 30): **Putting on Holiday for a period of Two Years**

(c) Subsequent instances (**more than two**) in other ongoing order (s)/ contract (s) or new order (s) /contact (s) on such Vendor/ Supplier/ Contractor/ Consultant: **Putting on Holiday for a period of Three Years**

B) Where Poor/Non-Performance leading to termination of contract or Offloading of contract due to poor performance attributable to Vendor/Supplier/ Contractor/Consultant (under clause no. 32 (C) of GCC-Works)

	<b>ELECTRICAL WORKS (SUPPLY &amp; ERECTION) FOR ALTERNATE POWER SUPPLY ARRANGEMENT OF VIKARMPUR GUEST HOUSE AT TALCHER FERTILIZERS LTD., ANGUL, ODISHA</b>	PC-183/E/ 8001 /S-III	0	
		DOC. NO.	REV	
		Page - 58 - of 115		

- (a) **First instance: Advisory notice (Yellow Card)** shall be issued and Vendor/Supplier/Contractor /Consultant shall be put on watch list for a period of Three (3) Years.

Further such vendor will not be allowed to participate in the re-tender of the same supply/work/services of that location which has terminated / offloaded. Moreover, it will be ensured that all other action as per provision of contract including forfeiture of Contract Performance Security (CPS) etc. are undertaken.

However, such vendor will be allowed to participate in all other tenders and to execute other ongoing order/ contract (s) or new contract/ order (s).

The Yellow card will be automatically revoked after a period of three years unless the same is converted into Red Card due to subsequent instances of poor/ non-performance in other ongoing order (s)/ contract (s) or new order (s) /contact (s) on such Vendor/ Supplier/ Contractor/ Consultant.

- (b) **Second instances** in other ongoing order (s)/ contract (s) or new order (s) /contact (s) on such Vendor/ Supplier/ Contractor/ Consultant: **Holiday (Red Card)** for period of One Year and they shall also to be considered for Suspension.
- (c) **Subsequent instances (more than two)** in other ongoing order (s)/ contract (s) or new order (s) /contact (s) on such Vendor/ Supplier/ Contractor/ Consultant: **Holiday (Red Card) for period of Three Years and they shall also to be considered for Suspension.**

- (C) Where Performance rating is "FAIR":  
Issuance of warning to such defaulting Vendor/ Supplier/Contractor/ Consultant to improve their performance.

## 5.2 FOR CONSULTANCY JOBS

Monitoring and Evaluation of consultancy jobs will be carried out in the same way as described in para 5.1 for Projects.

## 5.3 FOR OPERATION & MAINTENANCE

- i) Evaluation of performance of Vendors/ Suppliers/Contractors/ Consultants in case of Operation and Maintenance shall be done immediately after execution of order/ contract.
- ii) After execution of orders a Performance Rating Data Sheet (Format at Annexure-2) shall be prepared for Orders by Site C&P and for Contracts/Services by respective Engineer-In-Charge.
- iii) Depending upon Performance Rating, following action shall be initiated by EIC:

	<b>ELECTRICAL WORKS (SUPPLY &amp; ERECTION) FOR ALTERNATE POWER SUPPLY ARRANGEMENT OF VIKARMPUR GUEST HOUSE AT TALCHER FERTILIZERS LTD., ANGUL, ODISHA</b>	PC-183/E/ 8001 /S-III	0	
		DOC. NO.	REV	
		Page - 59 - of 115		

Sl. No.	Performance Rating	Action
1	<b>POOR</b>	Seek explanation for Poor performance
2.	<b>FAIR</b>	Seek explanation for Fair performance
3	<b>GOOD</b>	Letter to the concerned for improving performance in future.
4	<b>VERY GOOD</b>	No further action

- iv) Reply from concerned Vendor/ Supplier/Contractor/ Consultant shall be examined. In case of satisfactory reply, Performance Rating data Sheet to be closed with a letter to the concerned for improving performance in future.
- v) When no reply is received or reasons indicated are unsatisfactory, the following actions need to be taken:

- A) Where performance rating is “POOR” (as per Performance Rating carried out after execution of Order/ Contract and where no reply/ unsatisfactory reply is received from party against the letter seeking the explanation from Vendor/Supplier/Contractor/ Consultant along with sharing the performance rating)

Recommend such defaulting Vendor/Supplier/Contractor/ Consultant for the following action:

- (a) **First such instance: Advisory notice (Yellow Card)** shall be issued and Vendor/Supplier/Contractor/ Consultant shall be put on watch list for a period of Three (3) Years. Such vendor will be allowed to participate in all other tenders and to execute other ongoing order/ contract (s) or new contract/ order (s). The Yellow card will be automatically revoked after a period of three years unless the same is converted into Red Card due to subsequence instances of poor/ non-performance in other ongoing order (s)/ contract (s) or new order (s) /contact (s) on such Vendor/ Supplier/ Contractor/ Consultant.
- (b) **Second such instance in other ongoing order (s)/ contract (s) or new order (s) /contact (s) on such Vendor/ Supplier/ Contractor/ Consultant**
- (i) Poor Performance due to reasons other than Quality: **Putting on Holiday for a period of One Year**
- (ii) Poor Performance on account of Quality (if any mark obtained against Quality parameter is less than 30): **Putting on Holiday for a period of Two Years**
- (c) Subsequent instances (**more than two**) in other ongoing order (s)/ contract (s) or new order (s) /contact (s) on such Vendor/ Supplier/ Contractor/ Consultant: **Putting on Holiday for a period of Three Years**

	<b>ELECTRICAL WORKS (SUPPLY &amp; ERECTION) FOR ALTERNATE POWER SUPPLY ARRANGEMENT OF VIKARMPUR GUEST HOUSE AT TALCHER FERTILIZERS LTD., ANGUL, ODISHA</b>	PC-183/E/ 8001 /S-III	0	
		DOC. NO.	REV	
		Page - 60 - of 115		

B) Where Poor/Non-Performance leading to termination of contract or Offloading of contract due to poor performance attributable to Vendor/Supplier/ Contractor/Consultant (under clause no. 32 (C) of GCC-Works)

- (a) **First instance: Advisory notice (Yellow Card)** shall be issued and Vendor/Supplier/Contractor /Consultant shall be put on watch list for a period of Three (3) Years. Further such vendor will not be allowed to participate in the re-tender of the same supply/work/services of that location which has terminated / offloaded. Moreover, it will be ensured that all other action as per provision of contract including forfeiture of Contract Performance Security (CPS) etc. are undertaken. However, such vendor will be allowed to participate in all other tenders and to execute other ongoing order/ contract (s) or new contract/ order (s). The Yellow card will be automatically revoked after a period of three years unless the same is converted into Red Card due to subsequence instances of poor/ non-performance in other ongoing order (s)/ contract (s) or new order (s) /contact (s) on such Vendor/ Supplier/ Contractor/ Consultant.
- (b) **Second instances** in other ongoing order (s)/ contract (s) or new order (s) /contact (s) on such Vendor/ Supplier/ Contractor/ Consultant: **Holiday (Red Card)** for period of One Year and they shall also to be considered for Suspension.
- (c) **Subsequent instances (more than two)** in other ongoing order (s)/ contract (s) or new order (s) /contact (s) on such Vendor/ Supplier/ Contractor/ Consultant: **Holiday (Red Card) for period of Three Years and they shall also to be considered for Suspension.**

(C) Where Performance rating is "FAIR"  
Issuance of warning to such defaulting Vendors/Contractors/Consultants to improve their performance.

## 6.0 REVIEW & RESTORATION OF PARITES PUT ON HOLIDAY

6.1 An order for Holiday passed for a certain specified period shall deemed to have been automatically revoked on the expiry of that specified period and it will not be necessary to issue a specific formal order of revocation.

Further, in case Vendor/ Supplier/Contractor/ Consultant is put on holiday due to quality, and new order is placed on bidder after restoration of Vendor/ Supplier/Contractor/ Consultant, such order will be properly monitored during execution stage by the concerned site.

## 7.0 EFFECT OF HOLIDAY

	<b>ELECTRICAL WORKS (SUPPLY &amp; ERECTION) FOR ALTERNATE POWER SUPPLY ARRANGEMENT OF VIKARMPUR GUEST HOUSE AT TALCHER FERTILIZERS LTD., ANGUL, ODISHA</b>	PC-183/E/ 8001 /S-III	0	
		DOC. NO.	REV	
		Page - 61 - of 115		

- 7.1 If a Vendor/ Supplier/Contractor/ Consultant is put on Holiday, such Vendor/ Supplier/Contractor/ Consultant shall not be considered in ongoing tenders/future tenders.
- 7.2 However, if such Vendor/ Supplier/Contractor/ Consultant is already executing any other order/ contract and their performance is satisfactory in terms of the relevant contract, should be allowed to continue till its completion without any further increase in scope except those incidental to original scope mentioned in the contract. In such a case CPBG will not be forfeited and payment will be made as per provisions of concerned contract. However, this would be without prejudice to other terms and conditions of the contract.
- 7.3. Effect on other ongoing tendering:
- 7.3.1 after issue of the enquiry /bid/tender but before opening of Technical bid, the bid submitted by the party shall be ignored.
- 7.3.2 after opening Technical bid but before opening the Price bid, the Price bid of the party shall not be opened and BG/EMD submitted by the party shall be returned to the party.
- 7.3.3 After opening of price, BG/EMD made by the party shall be returned; the offer of the party shall be ignored & will not be further evaluated. If errant party emerges as the lowest (L1), then such tender shall also be cancelled and re-invited.
- 8.0** While putting the Vendor/ Supplier/Contractor/ Consultant on holiday as per the procedure, the holding company, subsidiary, joint venture, sister concerns, group division of the errant Vendor/ Supplier/Contractor/ Consultant shall not be considered for putting on holiday list.
- Any bidder, put on holiday, will not be allowed to bid through consortium route also in new tender during the period of holiday.
- 9.0** If an unsuccessful bidder makes any vexatious, frivolous or malicious complaint against the tender process with the intention of delaying or defeating any procurement or causing loss to TFL or any other bidder, such bidder will be put on holiday for a period of six months, if such complaint is proved to be vexatious, frivolous or malicious, after following the due procedure.
- 10. APPEAL AGAINST THE DECISION OF THE COMPETENT AUTHORITY:**
- (a) The party may file an appeal against the order of the Competent Authority for putting the party on Holiday list. The appeal shall be filed to Appellate Authority. Such an appeal shall be preferred within one month from the of receipt of Holiday order.
- (b) Appellate Authority would consider the appeal and pass appropriate order which shall be communicated to the party as well as the Competent Authority.
- (c) Appeal process may be completed within 45 days of filing of appeal with the Appellate Authority.



	<b>ELECTRICAL WORKS (SUPPLY &amp; ERECTION) FOR ALTERNATE POWER SUPPLY ARRANGEMENT OF VIKARMPUR GUEST HOUSE AT TALCHER FERTILIZERS LTD., ANGUL, ODISHA</b>	PC-183/E/ 8001 /S-III	0	
		DOC. NO.	REV	
		Page - 62 - of 115		

(d) “Appellate Authority” shall mean Committee of Directors consisting of Director (Finance) and Director (BD) for works centers under Director (Projects). For all other cases committee of Directors shall consist of Director (Finance) & Director (Projects).

11. **ERRANT BIDDER**

In case after price bid opening the lowest evaluated bidder (L1) is not awarded the job for any mistake committed by him in bidding or withdrawal of bid or modification of bid or varying any term in regard thereof leading to re-tendering, TFL shall forfeit EMD paid by the bidder and such bidders shall be debarred from participation in re-tendering of the same job(s)/item(s).

Further, such bidder will be put on holiday for a period of six months after following the due procedure.

12. In case CBIC (Central Board of Indirect Taxes and Customs)/ any tax authority / any equivalent government agency brings to the notice of TFL that the Supplier has not remitted the amount towards GST (CGST & SGST/UTGST or IGST) collected from TFL to the government exchequer, then, that Supplier shall be put under Holiday list of TFL for period of six months after following the due procedure. This action will be in addition to the right of recovery of financial implication arising on TFL.



	<b>ELECTRICAL WORKS (SUPPLY &amp; ERECTION) FOR ALTERNATE POWER SUPPLY ARRANGEMENT OF VIKARMPUR GUEST HOUSE AT TALCHER FERTILIZERS LTD., ANGUL, ODISHA</b>	PC-183/E/ 8001 /S-III	0	
		DOC. NO.	REV	
		Page - 63 - of 115		

Annexure-1

**TALCHER FERTILIZERS LIMITED  
PERFORMANCE RATING DATA SHEET  
(FOR PROJECTS/ CONSULTANCY JOBS)**

- i) Project/Work Centre :  
ii) Order/ Contract No. & date :  
iii) Brief description of Items :  
Works/Assignment  
iv) Order/Contract value (Rs.) :  
v) Name of Vendor/Supplier/ :  
Contractor/ Consultant  
vi) Contracted delivery/ :  
Completion Schedule  
vii) Actual delivery/ :  
Completion date

Performance Parameter	Delivery/ Completion Performance	Quality Performance	Reliability Performance#	Total
Maximum Marks	40	40	20	100
Marks Allotted				

Note:

Remarks (if any)

PERFORMANCE RATING (\*\*)

Note :

(#) Vendor/Supplier/Contractor/Consultant who seek repeated financial assistance or deviation beyond contract payment term or seeking direct payment to the sub-vendor/sub-contractor due to financial constraints, then '0' marks should be allotted against Reliability Performance.

(\*) Allocation of marks should be as per enclosed instructions

(\*\*) Performance rating shall be classified as under :

Sl. No.	Range (Marks)	Rating
1	60 & below	POOR
2	61-75	FAIR
3	76-90	GOOD
4	More than 90	VERY GOOD

Signature of  
Authorised Signatory:

Name:

Designation:

**Instructions for allocation of marks**

1. Marks are to be allocated as under :

**1.1 DELIVERY/ COMPLETION PERFORMANCE**

**40**

**Marks**

**Delivery Period/  
Marks**

**Delay in Weeks**

	<b>ELECTRICAL WORKS (SUPPLY &amp; ERECTION) FOR ALTERNATE POWER SUPPLY ARRANGEMENT OF VIKARMPUR GUEST HOUSE AT TALCHER FERTILIZERS LTD., ANGUL, ODISHA</b>	PC-183/E/ 8001 /S-III	0	
		DOC. NO.	REV	
		Page - 64 - of 115		

### Completion Schedule

a) Upto 3 months	Before CDD	40
	Delay upto 4 weeks	35
	" 8 weeks	30
	" 10 weeks	25
	" 12 weeks	20
	" 16 weeks	15
	More than 16 weeks	0
b) Above 3 months	Before CDD	40
	Delay upto 4 weeks	35
	" 8 weeks	30
	" 10 weeks	25
	" 16 weeks	20
	" 20 weeks	15
	" 24 weeks	10
	More than 24 weeks	0

### 1.2 QUALITY PERFORMANCE

**40 Marks**

	For Normal Cases : No Defects/ No Deviation/ No failure:	40
marks		
	i) Rejection/Defects	10
marks	Marks to be allocated on	
	prorata basis for acceptable quantity as compared to total quantity for normal cases	
	ii) When quality	0
marks	Failure of severe nature	
	failure endanger	5 marks
marks	system integration	10-25
	and safety of the system	
	iii) Number of	5
marks	1. No deviation	
	2. No. of deviations $\leq 2$	2
marks		
	3. No. of deviations $> 2$	0
marks		

	<b>ELECTRICAL WORKS (SUPPLY &amp; ERECTION) FOR ALTERNATE POWER SUPPLY ARRANGEMENT OF VIKARMPUR GUEST HOUSE AT TALCHER FERTILIZERS LTD., ANGUL, ODISHA</b>	PC-183/E/ 8001 /S-III	0	
		DOC. NO.	REV	
		Page - 65 - of 115		

**1.3 RELIABILITY PERFORMANCE**

**20 Marks**

<b>A.</b>	<b>FOR WORKS/CONTRACTS</b>	
i)	Submission of order acceptance, agreement, PBG, Drawings and other documents within time	4 marks
ii)	Mobilization of resources as per Contract and in time	4 marks
iii)	Liquidation of Check-list points	4 marks
iv)	Compliance to statutory and HS&E requirements  or  Reliability of Estimates/Design/Drawing etc. in case of Consultancy jobs	4 marks
v)	Timely submission of estimates and other documents for Extra, Substituted & AHR items	4 marks
<b>B.</b>	<b>FOR SUPPLIES</b>	
i)	Submission of order acceptance, PBG, Drawings and other documents within time	5 marks
ii)	Attending complaints and requests for after sales service/ warranty repairs and/ or query/ advice (upto the evaluation period).	5 marks
iii)	Response to various correspondence and conformance to standards like ISO	5 marks
iv)	Submission of all required documents including Test Certificates at the time of supply	5 marks

	<b>ELECTRICAL WORKS (SUPPLY &amp; ERECTION) FOR ALTERNATE POWER SUPPLY ARRANGEMENT OF VIKARMPUR GUEST HOUSE AT TALCHER FERTILIZERS LTD., ANGUL, ODISHA</b>	PC-183/E/ 8001 /S-III	0	
		DOC. NO.	REV	
		Page - 66 - of 115		

Annexure-2

**TALCHER FERTILIZERS LIMITED  
PERFORMANCE RATING DATA SHEET  
(FOR O&M)**

- i) Location :
- ii) Order/ Contract No. & date :
- iii) Brief description of Items :  
Works/Assignment :
- iv) Order/Contract value (Rs.) :
- v) Name of Vendor/Supplier/ :  
Contractor/ Consultant :
- vi) Contracted delivery/ :  
Completion Schedule :
- vii) Actual delivery/ :  
Completion date :

Performance Parameter	Delivery Performance	Quality Performance	Reliability Performance#	Total
Maximum Marks	40	40	20	100
Marks Allotted (*)				

Remarks (if any)

PERFORMANCE RATING (\*\*)

Note :

(#) Vendor/Supplier/Contractor/Consultant who seek repeated financial assistance or deviation beyond contract payment term or seeking direct payment to the sub-vendor/sub-contractor due to financial constraints, then '0' marks should be allotted against Reliability Performance

(\*) Allocation of marks should be as per enclosed instructions

(\*\*) Performance rating shall be classified as under :

Sl. No.	Range (Marks)	Rating
1	60 & below	POOR
2	61-75	FAIR
3	76-90	GOOD
4	More than 90	VERY GOOD

Signature of  
Authorised Signatory:

Name:

Designation:

**Instructions for allocation of marks (For O&M)**

1. Marks are to be allocated as under :

**1.1 DELIVERY/ COMPLETION PERFORMANCE** **40**  
**Marks**

<b>Delivery Period/ Completion Schedule</b>	<b>Delay in Weeks</b>
---	-----------------------

a) Upto 3 months	Before CDD	40
------------------	------------	----

	<b>ELECTRICAL WORKS (SUPPLY &amp; ERECTION) FOR ALTERNATE POWER SUPPLY ARRANGEMENT OF VIKARMPUR GUEST HOUSE AT TALCHER FERTILIZERS LTD., ANGUL, ODISHA</b>	PC-183/E/ 8001 /S-III	0	
		DOC. NO.	REV	
		Page - 67 - of 115		

Delay upto 4 weeks	35
" 8 weeks	30
" 10 weeks	25
" 12 weeks	20
" 16 weeks	15
More than 16 weeks	0

b) Above 3 months	Before CDD	40
	Delay upto 4 weeks	35
	" 8 weeks	30
	" 10 weeks	25
	" 16 weeks	20
	" 20 weeks	15
	" 24 weeks	10
	More than 24 weeks	0

**1.2 QUALITY PERFORMANCE 40 Marks**

marks	For Normal Cases : No Defects/ No Deviation/ No failure:	40
marks	i) Rejection/Defects	Marks to be allocated on 10
		prorata basis for acceptable quantity as compared to total quantity for normal cases
marks	ii) When quality	Failure of severe nature 0
marks	failure endanger	- Moderate nature 5
marks	system integration	- low severe nature 10-25
	and safety of the system	
marks	iii) Number of	1. No deviation 5
marks	deviations	2. No. of deviations $\leq 2$ 2
marks		3. No. of deviations $> 2$ 0

	<b>ELECTRICAL WORKS (SUPPLY &amp; ERECTION) FOR ALTERNATE POWER SUPPLY ARRANGEMENT OF VIKARMPUR GUEST HOUSE AT TALCHER FERTILIZERS LTD., ANGUL, ODISHA</b>	PC-183/E/ 8001 /S-III	0	
		DOC. NO.	REV	
		Page - 68 - of 115		

**1.3 RELIABILITY PERFORMANCE**

**20 Marks**

<b>A.</b>	<b>FOR WORKS/CONTRACTS</b>	
i)	Submission of order acceptance, agreement, PBG, Drawings and other documents within time	4 marks
ii)	Mobilization of resources as per Contract and in time	4 marks
iii)	Liquidation of Check-list points	4 marks
iv)	Compliance to statutory and HS&E requirements  or  Reliability of Estimates/Design/Drawing etc. in case of Consultancy jobs	4 marks
v)	Timely submission of estimates and other documents for Extra, Substituted & AHR items	4 marks
<b>B.</b>	<b>FOR SUPPLIES</b>	
i)	Submission of order acceptance, PBG, Drawings and other documents within time	5 marks
ii)	Attending complaints and requests for after sales service/ warranty repairs and/ or query/ advice (upto the evaluation period).	5 marks
iii)	Response to various correspondence and conformance to standards like ISO	5 marks
iv)	Submission of all required documents including Test Certificates at the time of supply	5 marks

	<b>ELECTRICAL WORKS (SUPPLY &amp; ERECTION) FOR ALTERNATE POWER SUPPLY ARRANGEMENT OF VIKARMPUR GUEST HOUSE AT TALCHER FERTILIZERS LTD., ANGUL, ODISHA</b>	PC-183/E/ 8001 /S-III	0	
		DOC. NO.	REV	
		Page - 69 - of 115		

**ANNEXURE-III**

**ADDENDUM TO INSTRUCTIONS TO BIDDERS  
(INSTRUCTIONS FOR PARTICIPATION IN CPP PORTAL)**

**Instructions to the Bidders to submit the bids online through the Central Public Procurement Portal for e-Procurement at <https://eprocure.gov.in/eprocure/app>**

1. Possession of valid Digital Signature Certificate (DSC) and enrolment/registration of the contractors/bidders on the e-procurement/ e-tender portal is a prerequisite for e-tendering.
2. Bidder should do the enrolment in the e-procurement site using the “Click here to Enroll” option available on the home page. Portal enrolment is generally free of charge. During enrolment/registration, the bidders should provide the correct/true information including valid email id. All the correspondence shall be made directly with the contractors/bidders through email id provided.
3. Bidder need to login to the site thro’ their user ID/ password chosen during enrolment/registration.
4. Then the Digital Signature Certificate (Class II or Class III Certificates with signing key usage) issued by SIFY / TCS / nCode / eMudra or any Certifying Authority recognized by CCA India on eToken / Smart Card, should be registered.
5. The DSC that is registered only should be used by the bidder and should ensure safety of the same.
6. Bidder may go through the NIT / tenders published on the site and download the required NIT documents/schedules for the tenders he/she is interested.
7. After downloading / getting the NIT/ Tender document/schedules, the Bidder should go thru’ them carefully and then submit the documents as asked, otherwise bid will be rejected.
8. If there are any clarifications, this may be obtained online thro’ the tender site, or thro’ the contact details. Bidder should take into account the corrigendum published before submitting the bids online.
9. Bidder then logs in to the site through the secured log in by giving the user id/ password chosen during enrolment/registration and then by giving the password of the e-Token / Smart Card to access DSC.
10. Bidder selects the tender which he/she is interested in by using the search option & then moves it to the ‘my tenders’ folder.
11. From my tender folder, he / she selects the tender to view all the details indicated.
12. It is construed that the bidder has read all the terms and conditions before submitting their offer. Bidder should go through the tender schedules carefully and upload the documents as asked otherwise, the bid will be rejected.

	<b>ELECTRICAL WORKS (SUPPLY &amp; ERECTION) FOR ALTERNATE POWER SUPPLY ARRANGEMENT OF VIKARMPUR GUEST HOUSE AT TALCHER FERTILIZERS LTD., ANGUL, ODISHA</b>	PC-183/E/ 8001 /S-III	0	
		DOC. NO.	REV	
		Page - 70 - of 115		

13. Bidder, in advance, should get ready the bid documents to be submitted as indicated in the tender document/schedule and generally, they can be in PDF/xls/rar/zip/dwf formats. If there is more than one document, they can be clubbed together and can be provided in the requested format. Each document to be uploaded through online for the tenders should be less than 2 MB. If any document is more than 2MB, it can be reduced through zip/rar and the same can be uploaded, if permitted. Bidders Bid documents may be scanned with 100 dpi with black and white option. However of the file size is less than 1 MB the transaction uploading time will be very fast.
14. If there are any clarifications, this may be obtained through the site, or during the pre-bid meeting if any. Bidder should take into account the corrigendum published from time to time before submitting the online bids.
15. The Bidders can update well in advance, the documents such as certificates, annual report details etc., under My Space option and these can be selected as per tender requirements and then send along with bid documents during bid submission. This will facilitate the bid submission process faster by reducing upload time of bids.
16. Bidder should submit the EMD as specified in the tender. The original should be posted/couriered/given in person to the Tender Inviting Authority, within the bid submission due date & time for the tender. Scanned copy of the instrument should be uploaded as part of the offer.
17. While submitting the bids online, the bidder reads the terms & conditions and accepts the same to proceed further to submit the bid packets.
18. The bidder has to select the payment option as offline to pay the Tender Fee/ EMD as applicable and enter details of the instruments.
19. The details of the DD/any other accepted instrument, physically sent, should tally with the details available in the scanned copy and the data entered during bid submission time. Otherwise submitted bid will not be acceptable.
20. The bidder has to digitally sign and upload the required bid documents one by one as indicated. Bidders to note that the very act of using DSC for downloading the bids and uploading their offers shall be deemed to be a confirmation that they have read all sections and pages of the bid document including General conditions of contract without any exception and have understood the entire document and are clear about the requirements of the tender requirements.
21. The bidder has to upload the relevant files required as indicated in the cover content. In case of any irrelevant files, the bid will be rejected.
22. If the price bid format is provided in a spread sheet file like BoQ\_xxxx.xls, the rate offered should be entered in the allotted space only and uploaded after filling the relevant columns. The Price Bid / BOQ template must not be modified/ replaced by the bidder; else the bid submitted is liable to be rejected for this tender.
23. The bidders are requested to submit the bids through online e-tendering system to the Tender Inviting Authority (TIA) well before the bid submission end date & time (as per Server System Clock). The TIA will not be held responsible for any sort of delay or the difficulties faced during the submission of bids online by the bidders at the eleventh hour.



	<b>ELECTRICAL WORKS (SUPPLY &amp; ERECTION) FOR ALTERNATE POWER SUPPLY ARRANGEMENT OF VIKARMPUR GUEST HOUSE AT TALCHER FERTILIZERS LTD., ANGUL, ODISHA</b>	PC-183/E/ 8001 /S-III	0	
		DOC. NO.	REV	
		Page - 71 - of 115		

24. After the bid submission (i.e. after Clicking “Freeze Bid Submission” in the portal), the acknowledgement number, given by the system should be printed by the bidder and kept as a record of evidence for online submission of bid for the particular tender and will also act as an entry pass to participate in the bid opening date.
25. The time settings fixed in the server side & displayed at the top of the tender site, will be valid for all actions of requesting, bid submission, bid opening etc., in the e-tender system. The bidders should follow this time during bid submission.
26. All the data being entered by the bidders would be encrypted using PKI encryption techniques to ensure the secrecy of the data. The data entered will not be viewable by unauthorized persons during bid submission & not be viewable by any one until the time of bid opening.
27. Any bid document that is uploaded to the server is subjected to symmetric encryption using a system generated symmetric key. Further this key is subjected to asymmetric encryption using buyers/bid openers public keys. Overall, the uploaded tender documents become readable only after the tender opening by the authorized bid openers.
28. The confidentiality of the bids is maintained since the secured Socket Layer 128 bit encryption technology is used. Data storage encryption of sensitive fields is done.
29. The bidder should logout of the tendering system using the normal logout option available at the top right hand corner and not by selecting the (X) exit option in the browser.

**Note:**

A bidder shall submit only one bid in the same bidding process. A Bidder who submits more than one bid will cause all their bids disqualified in the said bidding process.

---

	<b>ELECTRICAL WORKS (SUPPLY &amp; ERECTION) FOR ALTERNATE POWER SUPPLY ARRANGEMENT OF VIKARMPUR GUEST HOUSE AT TALCHER FERTILIZERS LTD., ANGUL, ODISHA</b>	PC-183/E/ 8001 /S-III	0	
		DOC. NO.	REV	
		Page - 72 - of 115		

**ANNEXURE-IV**

**BIDDING DATA SHEET (BDS)**

**ITB TO BE READ IN CONJUNCTION WITH THE FOLLOWING:**

<b>A. GENERAL</b>					
ITB clause	Description				
1.2	The Invitation for Bids/ Tender no is : PNP/PC-183/E/8001/NCB				
1.1	The Employer/Owner is: TALCHER FERTILIZERS LIMITED				
2.1	The name of the Works/Services to be performed is: ELECTRICAL WORKS (SUPPLY & ERECTION) FOR ALTERNATE POWER SUPPLY ARRANGEMENT OF VIKARMPUR GUEST HOUSE AT TALCHER FERTILIZERS LTD., ANGUL, ODISHA				
3.0	BIDS FROM CONSORTIUM/ JOINT VENTURE  <table border="1" style="margin-left: auto; margin-right: auto;"> <tr> <td style="text-align: center;">APPLICABLE</td> <td style="width: 50px;"></td> </tr> <tr> <td style="text-align: center;">NOT APPLICABLE</td> <td style="text-align: center;">√</td> </tr> </table>	APPLICABLE		NOT APPLICABLE	√
APPLICABLE					
NOT APPLICABLE	√				
<b>B. BIDDING DOCUMENT</b>					
ITB clause	Description				
8.1	For <b>clarification purposes</b> only, the communication address is: Projects & Development India Limited, (Project Management Department) P.D.I.L Bhawan, A-14, Sector-1, Noida , (India) Fax no.:0120-2529801  Kind Attention: Mr. Kailash Joshi Project Manager Tel no. : +91-120-2529842/43/47/51/53/54 Extn. 314 Fax no. : +91-120-2529801 E-mail : <a href="mailto:kjoshi@pdilin.com">kjoshi@pdilin.com</a>				
<b>C. PREPARATION OF BIDS</b>					
ITB clause	Description				
12.0	Additional Provision for Schedule of Rate/ Bid Price are as under: <b>[Please refer Section VII, Schedule of Rate]</b>				
14.0	The currency of the Bid shall be INR				
15.0	The bid validity period shall be <b>120 days from final 'Bid Due Date'</b> .				
<b>D. SUBMISSION AND OPENING OF BIDS</b>					

	<b>ELECTRICAL WORKS (SUPPLY &amp; ERECTION) FOR ALTERNATE POWER SUPPLY ARRANGEMENT OF VIKARMPUR GUEST HOUSE AT TALCHER FERTILIZERS LTD., ANGUL, ODISHA</b>	PC-183/E/ 8001 /S-III	0	
		DOC. NO.	REV	
		Page - 73 - of 115		

ITB clause	Description				
<b>22.3 and 4.0 of IFB</b>	<p>For <b>bid submission purposes</b>, submission of physical document as per clause no. 4.0 of IFB, the address to which documents are to be sent is : Projects &amp; Development India Limited, (Project Management Department) P.D.I.L Bhawan, A-14, Sector-1, Noida , (India) Fax no.:0120-2529801</p> <p>Kind Attention: Mr. Mr. Kailash Joshi Project Manager</p>				
<b>E. EVALUATION, AND COMPARISON OF BIDS</b>					
ITB clause	Description				
<b>32.0</b>	Evaluation Methodology is mentioned in Section-II.				
<b>33.0</b>	Compensation for Extended Stay: <table border="1" style="margin-left: 40px; width: 100%;"> <tr> <td style="text-align: center;">APPLICABLE</td> <td></td> </tr> <tr> <td style="text-align: center;">NOT APPLICABLE</td> <td style="text-align: center;">√</td> </tr> </table>	APPLICABLE		NOT APPLICABLE	√
APPLICABLE					
NOT APPLICABLE	√				
<b>F. AWARD OF CONTRACT</b>					
ITB clause	Description				
<b>37.0</b>	State of which stamp paper is required for Contract Agreement: Uttar Pradesh / State where Bidder's registered office is located				
<b>38.0</b>	Contract Performance Security/ Security Deposit <table border="1" style="margin-left: 40px; width: 100%;"> <tr> <td style="text-align: center;">APPLICABLE</td> <td style="text-align: center;">√</td> </tr> <tr> <td style="text-align: center;">NOT APPLICABLE</td> <td></td> </tr> </table> <p>Contract Performance Security @ 3% of Total Order/ Contract Value (excluding GST) within 30 days of FOA/ notification of award.</p>	APPLICABLE	√	NOT APPLICABLE	
APPLICABLE	√				
NOT APPLICABLE					
<b>40.0</b>	Whether tendered item is splittable or divisible : <table border="1" style="margin-left: 40px; width: 100%;"> <tr> <td style="text-align: center;">YES</td> <td></td> </tr> <tr> <td style="text-align: center;">NO</td> <td style="text-align: center;">√</td> </tr> </table>	YES		NO	√
YES					
NO	√				
<b>41.0</b>	Provision of AHR Item :				

	<b>ELECTRICAL WORKS (SUPPLY &amp; ERECTION) FOR ALTERNATE POWER SUPPLY ARRANGEMENT OF VIKARMPUR GUEST HOUSE AT TALCHER FERTILIZERS LTD., ANGUL, ODISHA</b>	PC-183/E/ 8001 /S-III	0	
		DOC. NO.	REV	
		Page - 74 - of 115		

	<table border="1"> <tr> <td>APPLICABLE</td> <td style="text-align: center;">√</td> </tr> <tr> <td>NOT APPLICABLE</td> <td></td> </tr> </table>	APPLICABLE	√	NOT APPLICABLE	
APPLICABLE	√				
NOT APPLICABLE					
<b>49.0</b>	Quarterly Closure of Contract <table border="1"> <tr> <td>APPLICABLE</td> <td></td> </tr> <tr> <td>NOT APPLICABLE</td> <td style="text-align: center;">√</td> </tr> </table>	APPLICABLE		NOT APPLICABLE	√
APPLICABLE					
NOT APPLICABLE	√				
<b>50.0</b>	Provisions for Startups <table border="1"> <tr> <td>APPLICABLE</td> <td style="text-align: center;">√</td> </tr> <tr> <td>NOT APPLICABLE</td> <td></td> </tr> </table>	APPLICABLE	√	NOT APPLICABLE	
APPLICABLE	√				
NOT APPLICABLE					
<b>Clause no. 27.3 of GCC</b>	Bonus for Early Completion: <table border="1"> <tr> <td>APPLICABLE</td> <td></td> </tr> <tr> <td>NOT APPLICABLE</td> <td style="text-align: center;">√</td> </tr> </table>	APPLICABLE		NOT APPLICABLE	√
APPLICABLE					
NOT APPLICABLE	√				

	<b>ELECTRICAL WORKS (SUPPLY &amp; ERECTION) FOR ALTERNATE POWER SUPPLY ARRANGEMENT OF VIKARMPUR GUEST HOUSE AT TALCHER FERTILIZERS LTD., ANGUL, ODISHA</b>	PC-183/E/ 8001 /S-III	0	
		DOC. NO.	REV	
		Page - 75 - of 115		

**ANNEXURE-V**

**POLICY TO PROVIDE PURCHASE PREFERENCE (LINKED WITH LOCAL CONTENT)**

	<b>ELECTRICAL WORKS (SUPPLY &amp; ERECTION) FOR ALTERNATE POWER SUPPLY ARRANGEMENT OF VIKARMPUR GUEST HOUSE AT TALCHER FERTILIZERS LTD., ANGUL, ODISHA</b>	PC-183/E/ 8001 /S-III	0	
		DOC. NO.	REV	
		Page - 76 - of 115		

### POLICY TO PROVIDE PURCHASE PREFERENCE (LINKED WITH LOCAL CONTENT)

In tune with Make in India (MII), the government has decided to incentivize the growth of local content in goods and services with objective to Support and boost the growth of Domestic Manufacturing sector.

#### Salient Points of Public Procurement (Preference to Make in India) Policy

Sr. No.	Description	Parameter / Document
1	Minimum Local Content for Availing Preference under this Policy	50%
2	Margin of Purchase Preference	20%
3	Documents to be submitted by bidder for availing Purchase Preference under this Policy (*)	<p>(a) <del>Self Certificate from bidder as per Form F-22</del></p> <p>OR</p> <p>(b) Certificate from the statutory auditor or cost auditor of the company (in case of companies) or from a practicing cost accountant or practicing chartered accountant as per <b>Form F-23</b>.</p>
4	Whether tender is divisible or not divisible	Not Divisible

	<b>ELECTRICAL WORKS (SUPPLY &amp; ERECTION) FOR ALTERNATE POWER SUPPLY ARRANGEMENT OF VIKARMPUR GUEST HOUSE AT TALCHER FERTILIZERS LTD., ANGUL, ODISHA</b>	PC-183/E/ 8001 /S-III	0	
		DOC. NO.	REV	
		Page - 77 - of 115		

**ANNEXURE-VI**

**FORMS & FORMAT**

**LIST OF FORMS & FORMAT**

Form No.	Description
F-1	BIDDER'S GENERAL INFORMATION
F-2	DECLARATION FOR BID SECURITY
F-3	LETTER OF AUTHORITY
F-4	PROFORMA OF "BANK GUARANTEE" FOR "CONTRACT PERFORMANCE SECURITY / SECURITY DEPOSIT"
F-5	AGREED TERMS & CONDITIONS
F-6	ACKNOWLEDGEMENT CUM CONSENT LETTER
F-7	BIDDER'S EXPERIENCE
F-8	CHECK LIST
F-9	FORMAT FOR CERTIFICATE FROM BANK IF BIDDER'S WORKING CAPITAL IS INADEQUATE
F-10	FORMAT FOR CHARTERED ACCOUNTANT CERTIFICATE FOR FINANCIAL CAPABILITY OF THE BIDDER
F-11	BIDDER'S QUERIES FOR PRE BID MEETING
F-12	E-BANKING FORMAT
F-13	INTEGRITY PACT
F-14	INDEMNITY BOND
F-15	POWER OF ATTORNEY
F-16	PROFORMA OF CONTRACT AGREEMENT
F-17	FAQ
F-18	SELF DECLARATION AGAINST POLICY FOR PROVIDING PREFERENCE TO DOMESTICALLY MANUFACTURED IRON & STEEL PRODUCTS IN GOVERNMENT PROCUREMENT
F-19	FORMAT FOR UNDERTAKING FROM TPIA
F-20	UNDERTAKING ON LETTERHEAD REGARDING PROVISIONS FOR PROCUREMENT FROM A BIDDER WHICH SHARES A LAND BORDER WITH INDIA
F-21	CERTIFICATE FOR TENDERS FOR WORKS INVOLVING POSSIBILITY OF SUB-CONTRACTING
F-22	DECLARATION BY BIDDER TOWARDS MINIMUM LOCAL CONTENT (FOR SUPPLY OF GOODS / SERVICES / WORKS / EPC / LSTK )
F-23	CERTIFICATE FROM STATUTORY AUDITOR OR COST AUDITOR OF THE COMPANY (IN THE CASE OF COMPANIES) OR FROM A PRACTICING COST ACCOUNTANT OR PRACTICING CHARTERED ACCOUNTANT (IN RESPECT OF SUPPLIERS OTHER THAN COMPANIES) TOWARDS MINIMUM LOCAL CONTENT
F-24	UNDERTAKING REGARDING SUBMISSION CONTRACT PERFORMANCE SECURITY(CPS) / SECURITY DEPOSIT (SD) WITHIN STIPULATED TIME LINE
F-25	UNDERTAKING REGARDING SUBMISSION OF ELECTRONIC INVOICE (E-INVOICE AS PER GST LAWS)

**Note : For Applicability of above, refer to relevant Forms.**



	<b>ELECTRICAL WORKS (SUPPLY &amp; ERECTION) FOR ALTERNATE POWER SUPPLY ARRANGEMENT OF VIKARMPUR GUEST HOUSE AT TALCHER FERTILIZERS LTD., ANGUL, ODISHA</b>	PC-183/E/ 8001 /S-III	0	
		DOC. NO.	REV	
		Page - 78 - of 115		

**F-1**

**BIDDER'S GENERAL INFORMATION**

To,

**M/s TALCHER FERTILIZERS LIMITED  
NOIDA**

TENDER NO.:

1	Bidder Name	
2	Status of Firm	Proprietorship Firm/Partnership firm/ Limited/Others If Others Specify: _____ [Enclose certificate of Registration]
3	Name of Proprietor/Partners/Directors of the firm/company	
4	Number of Years in Operation	
5	Address of Registered Office: *In case of Partnership firm, enclose letter mentioning current address of the firm and the full names and current addresses of all the partners of the firm.	City: District: State: PIN/ZIP:
6	<b>Bidder's address where order/contract is to be placed</b>	City: District: State: PIN/ZIP:
7	Address from where Goods/ Services are to be dispatched/ provided along with GST no. <b>(In case supply of Goods/ Services are from multiple locations, addresses and GST no. of all such locations are to be provided).</b>	City: District: State: PIN/ZIP: GST No.:
8	Telephone Number of address where order is to be placed	(Country Code) (Area Code) (Telephone No.)
9	E-mail address	
10	Website	

	<b>ELECTRICAL WORKS (SUPPLY &amp; ERECTION) FOR ALTERNATE POWER SUPPLY ARRANGEMENT OF VIKARMPUR GUEST HOUSE AT TALCHER FERTILIZERS LTD., ANGUL, ODISHA</b>	PC-183/E/ 8001 /S-III	0	
		DOC. NO.	REV	
		Page - 79 - of 115		

11	ISO Certification, if any	{If yes, please furnish details}
12	PAN No.	[Enclose copy of PAN Card]
13	GST No.(refer sl. no. 8 above)	[Enclose copy of GST Certificate]
14	EPF Registration No.	[Enclose copy of EPF Registration Certificate]
15	ESI code No.	[Enclose copy of relevant document]
16	Whether Micro or Small Enterprise	Yes / No (If Yes, Bidder to submit requisite documents as specified in ITB: Clause No. 40)
17	Bidder's Offer no. and date	
18	Whether Bidder is Startups or not	Yes / No (If Yes, Bidder to submit requisite documents as specified in ITB: Clause No. 50)
19	In case of Start-up confirm the following:  (i) Date of its incorporation/ registration (ii) Whether turnover for any financial years since incorporation/ registration has exceed Rs.25 Crores.	

Place:  
Date:

[Signature of Authorized Signatory of Bidder]  
Name:  
Designation:  
Seal:

	<b>ELECTRICAL WORKS (SUPPLY &amp; ERECTION) FOR ALTERNATE POWER SUPPLY ARRANGEMENT OF VIKARMPUR GUEST HOUSE AT TALCHER FERTILIZERS LTD., ANGUL, ODISHA</b>	PC-183/E/ 8001 /S-III	0	
		DOC. NO.	REV	
		Page - 80 - of 115		

**F-2**

**DECLARATION FOR BID SECURITY  
(To be submitted on Letter head of Bidder)**

To,

M/s TALCHER FERTILIZERS LIMITED

---

SUB:

TENDER NO:

Dear Sir,

After examining / reviewing provisions of above referred tender documents (including all corrigendum/ Addenda), we M/s \_\_\_\_\_ (Name of Bidder) have submitted our offer/ bid no. \_\_\_\_\_.

We, M/s \_\_\_\_\_ (Name of Bidder) hereby understand that, according to your conditions, we are submitting this Declaration for Bid Security.

We understand that we will be put on watch list/holiday/ banning list (as per polices of TALCHER FERTILIZERS LIMITED in this regard), if we are in breach of our obligation(s) as per following:

- (a) have withdrawn/modified/amended, impairs or derogates from the tender, my/our Bid during the period of bid validity specified in the form of Bid; or
- (b) having been notified of the acceptance of our Bid by the TALCHER FERTILIZERS LIMITED during the period of bid validity:
  - (i) fail or refuse to execute the Contract, if required, or
  - (ii) fail or refuse to furnish the Contract Performance Security, in accordance provisions of tender document.
  - (iii) fail or refuse to accept 'arithmetical corrections' as per provision of tender document.
- (c) having indulged in corrupt/fraudulent /collusive/coercive practice as per procedure.

Place:

Date:

[Signature of Authorized Signatory of Bidder]

Name:

Designation:

Seal:

	<b>ELECTRICAL WORKS (SUPPLY &amp; ERECTION) FOR ALTERNATE POWER SUPPLY ARRANGEMENT OF VIKARMPUR GUEST HOUSE AT TALCHER FERTILIZERS LTD., ANGUL, ODISHA</b>	PC-183/E/ 8001 /S-III	0	
		DOC. NO.	REV	
		Page - 81 - of 115		

**F-3**  
**LETTER OF AUTHORITY**

[Proforma for Letter of Authority for Attending Subsequent 'Negotiations' / 'Pre-Bid Meetings' / 'Un-priced Bid Opening' / 'Price Bid Opening']

Ref:  
To,

Date:

**M/s TALCHER FERTILIZERS LIMITED  
NOIDA**

SUB:  
TENDER NO:

**Dear Sir,**

I/We, \_\_\_\_\_ hereby authorize the following representative(s) for attending any 'Negotiations' / 'Meetings [Pre-Bid Meeting]', 'Un-priced Bid Opening', 'Price Bid Opening' and for any subsequent correspondence / communication against the above Bidding Documents:

[1] Name & Designation \_\_\_\_\_ Signature \_\_\_\_\_  
Phone/Cell:  
Fax:  
E-mail: ..... @ .....

[2] Name & Designation \_\_\_\_\_ Signature \_\_\_\_\_  
Phone/Cell:  
Fax:  
E-mail: ..... @ .....

We confirm that we shall be bound by all commitments made by aforementioned authorised representative(s).

Place: \_\_\_\_\_ [Signature of Authorized Signatory of Bidder]  
Date: \_\_\_\_\_ Name:  
Designation:  
Seal:

Note: This "Letter of Authority" should be on the **"letterhead"** of the Firm / Bidder and should be signed by a person competent and having the 'Power of Attorney' to bind the Bidder. Not more than 'two [02] persons per Bidder' are permitted to attend "Techno-commercial / Un-priced" & "Price Bid" Openings. Bidders authorized representative is required to carry a copy of this authority letter while attending the un-priced and priced bid opening, the same shall be submitted to OWNER.

	<b>ELECTRICAL WORKS (SUPPLY &amp; ERECTION) FOR ALTERNATE POWER SUPPLY ARRANGEMENT OF VIKARMPUR GUEST HOUSE AT TALCHER FERTILIZERS LTD., ANGUL, ODISHA</b>	PC-183/E/ 8001 /S-III	0	
		DOC. NO.	REV	
		Page - 82 - of 115		

**F-4**

**PROFORMA OF "BANK GUARANTEE" FOR "CONTRACT PERFORMANCE SECURITY /  
SECURITY DEPOSIT"  
(ON NON-JUDICIAL STAMP PAPER OF APPROPRIATE VALUE)**

To, M/s Talcher Fertilizers Limited, Noida	<b>Bank Guarantee No.</b>	
	<b>Date of BG</b>	
	<b>BG Valid up to</b>	
	<b>Claim period upto (There should be three months gap between expiry date of BG&amp; Claim period)</b>	
	<b>Stamp Sl. No./e-Stamp Certificate No.</b>	

**Dear Sir(s),**

M/s. \_\_\_\_\_ having registered office at \_\_\_\_\_ (herein after called the "contractor/supplier" which expression shall wherever the context so require include its successors and assignees) have been placed/ awarded the job/work of

vide PO/DLOA /FOA No. \_\_\_\_\_ dated \_\_\_\_\_ for Talcher Fertilizers Limited having registered office at Plot 2/H, Kalpana Area, BJB Nagar, Khorda, Bhubaneswar-751014, Odisha (herein after called the "TFL" which expression shall wherever the context so require include its successors and assignees).

The Contract conditions provide that the SUPPLIER/CONTRACTOR shall pay a sum of Rs. \_\_\_\_\_ (Rupees \_\_\_\_\_) as full Contract Performance Guarantee in the form therein mentioned. The form of payment of Contract Performance Guarantee includes guarantee executed by Nationalized Bank/Scheduled Commercial Bank, undertaking full responsibility to indemnify Talcher Fertilizers Limited, in case of default.

The said M/s. \_\_\_\_\_ has approached us and at their request and in consideration of the premises we having our office at \_\_\_\_\_ have agreed to give such guarantee as hereinafter mentioned.

1. We \_\_\_\_\_ hereby undertake to give the irrevocable & unconditional guarantee to you that if default shall be made by M/s. \_\_\_\_\_ in performing any of the terms and conditions of the tender/order/contract or in payment of any money payable to Talcher Fertilizers Limited we shall on first demand pay without demur, contest, protest and/ or without any recourse to the contractor to TFL in such manner as TFL may direct the said amount of Rupees \_\_\_\_\_ only or

	<b>ELECTRICAL WORKS (SUPPLY &amp; ERECTION) FOR ALTERNATE POWER SUPPLY ARRANGEMENT OF VIKARMPUR GUEST HOUSE AT TALCHER FERTILIZERS LTD., ANGUL, ODISHA</b>	PC-183/E/ 8001 /S-III	0	
		DOC. NO.	REV	
		Page - 83 - of 115		

such portion thereof not exceeding the said sum as you may require from time to time.

2. You will have the full liberty without reference to us and without affecting this guarantee, postpone for any time or from time to time the exercise of any of the powers and rights conferred on you under the order/contract with the said M/s. \_\_\_\_\_ and to enforce or to forbear from endorsing any powers or rights or by reason of time being given to the said M/s. \_\_\_\_\_ and such postponement forbearance would not have the effect of releasing the bank from its obligation under this debt.
3. Your right to recover the said sum of Rs. \_\_\_\_\_ (Rupees \_\_\_\_\_) from us in manner aforesaid is absolute & unequivocal and will not be affected or suspended by reason of the fact that any dispute or disputes have been raised by the said M/s. \_\_\_\_\_ and/or that any dispute or disputes are pending before any officer, tribunal or court or arbitrator or any other authority/forum and any demand made by you in the bank shall be conclusive and binding. The bank shall not be released of its obligations under these presents by any exercise by you of its liberty with reference to matter aforesaid or any of their or by reason or any other act of omission or commission on your part or any other indulgence shown by you or by any other matter or changed what so ever which under law would, but for this provision, have the effect of releasing the bank.
4. The guarantee herein contained shall not be determined or affected by the liquidation or winding up dissolution or changes of constitution or insolvency of the said supplier/contractor but shall in all respects and for all purposes be binding and operative until payment of all money due to you in respect of such liabilities is paid.
5. The bank undertakes not to revoke this guarantee during its currency without your previous consent and further agrees that the guarantee shall continue to be enforceable until it is discharged by TFL in writing. However, if for any reason, the supplier/contractor is unable to complete the supply/work within the period stipulated in the order/contract and in case of extension of the date of delivery/completion resulting extension of defect liability period/guarantee period of the supplier/contractor fails to perform the supply/work fully, the bank hereby agrees to further extend this guarantee at the instance of the supplier/contractor till such time as may be determined by TFL. If any further extension of this guarantee is required, the same shall be extended to such required period on receiving instruction from M/s. \_\_\_\_\_ (contractor) on whose behalf this guarantee is issued.
6. Bank also agrees that TFL at its option shall be entitled to enforce this Guarantee against the bank (as principal debtor) in the first instant, without proceeding against the supplier/contractor and notwithstanding any security or other guarantee that TFL may have in relation to the supplier's/contractor's liabilities.
7. The amount under the Bank Guarantee is payable forthwith without any delay by Bank upon the written demand raised by TFL. Any dispute arising out of or in relation to the said Bank Guarantee shall be subject to the exclusive jurisdiction of courts at New Delhi.

	<b>ELECTRICAL WORKS (SUPPLY &amp; ERECTION) FOR ALTERNATE POWER SUPPLY ARRANGEMENT OF VIKARMPUR GUEST HOUSE AT TALCHER FERTILIZERS LTD., ANGUL, ODISHA</b>	PC-183/E/ 8001 /S-III	0	
		DOC. NO.	REV	
		Page - 84 - of 115		

8. Therefore, we hereby affirm that we are guarantors and responsible to you on behalf of the Supplier/ Contractor up to a total amount of \_\_\_\_\_ (amount of guarantees in words and figures) and we undertake to pay you, upon your first written demand declaring the Supplier/Contractor to be in default under the order/contract and without caveat or argument, any sum or sums within the limits of (amounts of guarantee) as aforesaid, without your needing to prove or show grounds or reasons for your demand or the sum specified therein.
9. We have power to issue this guarantee in your favor under Memorandum and Articles of Association and the undersigned has full power to do under the Power of Attorney, dated \_\_\_\_\_ granted to him / her by the Bank.
10. Notwithstanding anything contained herein: 11.
- a) The Bank's liability under this Guarantee shall not exceed (currency in figures) \_\_\_\_\_ (currency in words only) \_\_\_\_\_
  - b) This Guarantee shall remain in force upto \_\_\_\_\_ (this date should be expiry date of defect liability period of the Contract) and any extension(s) thereof; and
  - c) The Bank shall be released and discharged from all liability under this Guarantee unless a written claim or demand is issued to the Bank on or before the midnight of \_\_\_\_\_ (indicate date of expiry of claim period which includes minimum three months from the expiry of this Bank Guarantee) and if extended, the date of expiry of the last extension of this Guarantee. If a claim has been received by us within the said date, all the rights of TFL under this Guarantee shall be valid and shall not cease until we have satisfied that claim.

Yours faithfully,

\_\_\_\_\_  
Bank by its Constituted Attorney

Signature of a person duly  
Authorized to sign on behalf of  
the Bank



	<b>ELECTRICAL WORKS (SUPPLY &amp; ERECTION) FOR ALTERNATE POWER SUPPLY ARRANGEMENT OF VIKARMPUR GUEST HOUSE AT TALCHER FERTILIZERS LTD., ANGUL, ODISHA</b>	PC-183/E/ 8001 /S-III	0	
		DOC. NO.	REV	
		Page - 85 - of 115		

**INSTRUCTIONS FOR FURNISHING  
"CONTRACT PERFORMANCE SECURITY / SECURITY DEPOSIT" BY "BANK  
GUARANTEE"**

1. The Bank Guarantee by successful Bidder(s) will be given on non-judicial stamp paper as per 'stamp duty' applicable. The non-judicial stamp paper should be in name of the issuing bank. In case of foreign bank, the said Bank Guarantee to be issued by its correspondent bank in India on requisite nonjudicial stamp paper and place of Bid to be considered as Delhi.
2. The Bank Guarantee by Bidders will be given from bank as specified in Tender.
3. A letter from the issuing bank of the requisite Bank Guarantee confirming that said Bank Guarantee and all future communication relating to the Bank Guarantee shall be forwarded to Employer.
4. If a Bank Guarantee is issued by a commercial bank, then a letter to Employer and copy to Consultant (if applicable) confirming its net worth is more than Rs. 100,00,00,000.00 [Rupees One Hundred Crores] or its equivalent in foreign currency alongwith documentary evidence.

	<b>ELECTRICAL WORKS (SUPPLY &amp; ERECTION) FOR ALTERNATE POWER SUPPLY ARRANGEMENT OF VIKARMPUR GUEST HOUSE AT TALCHER FERTILIZERS LTD., ANGUL, ODISHA</b>	PC-183/E/ 8001 /S-III	0	
		DOC. NO.	REV	
		Page - 86 - of 115		

**ANNEXURE**

**MATTER TO BE MENTIONED IN COVERING LETTER TO BE SUBMITTED BY  
VENDOR ALONG WITH BANK GUARANTEE (BG)**

<b>1. Bank Guarantee No.</b>			
<b>2. Vendor Name</b>			
<b>3. Nature of Bank Guarantee [Please Tick(✓)whichever is applicable]</b>	Contract Performance Security (CPS)	Earnest Money Deposit (EMD)	Advance
<b>4. Purchase Order(PO)/Fax of Acceptance(FOA)/Detailed Letter of Acceptance (DLOA)No.</b>			
<b>5. Details of Bank issuing Bank Guarantee(BG)</b>			
(A)Name of Contact Person			
(B)E-mail ID			
(C)Address			
(D)Phone No. /Mobile No.			

	<b>ELECTRICAL WORKS (SUPPLY &amp; ERECTION) FOR ALTERNATE POWER SUPPLY ARRANGEMENT OF VIKARMPUR GUEST HOUSE AT TALCHER FERTILIZERS LTD., ANGUL, ODISHA</b>	PC-183/E/ 8001 /S-III	0	
		DOC. NO.	REV	
		Page - 87 - of 115		

**F-5**  
**AGREED TERMS & CONDITIONS**

To,  
**M/s TALCHER FERTILIZERS LIMITED**  
**NOIDA**

SUB:  
TENDER NO:

This Questionnaire duly filled in, signed & stamped must form part of Bidder's Bid and should be returned along with Un-priced Bid. Clauses confirmed hereunder need not be repeated in the Bid.

SI.	DESCRIPTION	BIDDER'S CONFIRMATION
1	Bidder's name and address	
2.	Bidder confirms currency of quoted prices is in Indian Rupees	
3.	Bidder confirms quoted prices will remain firm and fixed till complete execution of the order.	
4.1	Bidder confirms that they have quoted rate of <b>GST (CGST &amp; SGST/ UTGST or IGST)</b> in Price Schedule / Schedule of Rates (SOR)	Confirmed
4.2	Service Accounting Codes (SAC)/ Harmonized System of Nomenclature (HSN)	
4.3	Bidder hereby confirms that the quoted prices are in compliance with the Section 171 of CGST Act/ SGST Act as mentioned as clause no. 13.10 of ITB	
4.4	a. Whether bidder is liable to raise E-Invoice as per GST Act. b. If yes, bidder will raise E-Invoice and confirm compliance to provision of tender in this regard.	a. b.
4.5	i. Whether bidder as a seller is liable to levy TCS on sale of goods as defined under the said provision of Income Tax. ii. If yes, bidder as a seller will raise proper tax invoice on sale of goods to TFL showing TCS component. iii. Bidder as a seller will comply with all the statutory requirements of TCS regarding deposit of TCS with Government on receipt/collection of consideration from TFL and issue of TCS certificate to TFL timely. iv. If TFL is unable to avail the benefit of TCS Credit on such amount collected by the Supplier, for any reason attributable to Supplier, then TFL shall be entitled to deduct / recover such amount together with penalties and interest, if any, by adjusting any amounts to be paid or becomes payable in future to the Supplier under this contract or under any other contract.	i. ii. iii. iv.
5.	Bidder confirms acceptance of relevant Terms of Payment specified in the Bid Document.	

	<b>ELECTRICAL WORKS (SUPPLY &amp; ERECTION) FOR ALTERNATE POWER SUPPLY ARRANGEMENT OF VIKARMPUR GUEST HOUSE AT TALCHER FERTILIZERS LTD., ANGUL, ODISHA</b>	PC-183/E/ 8001 /S-III	0	
		DOC. NO.	REV	
		Page - 88 - of 115		

SI.	DESCRIPTION	BIDDER'S CONFIRMATION				
6.	Bidder confirms that Contract Performance Security will be furnished as per Bid Document.					
7.	Bidder confirms that Contract Performance Security shall be from any Indian scheduled bank or a branch of an International bank situated in India and registered with Reserve bank of India as scheduled foreign bank. However, in case of bank guarantees from banks other than the Nationalized Indian banks, the bank must be a commercial bank having net worth in excess of Rs 100 crores and a declaration to this effect shall be made by such commercial bank either in the Bank Guarantee itself or separately on its letterhead.					
8.	Bidder confirms compliance to Completion Schedule as specified in Bid document. Confirm contract period shall be reckoned from the date of Fax of Acceptance.					
9.	Bidder confirms acceptance of Price Reduction Schedule (PRS) for delay in completion schedule specified in Bid document. In case of delay, the bills shall be submitted after deducting the Price Reduction Schedule due to delay (refer PRS Clause).					
10.	a) Bidder confirms acceptance of all terms and conditions of Bid Document (all sections). b) Bidder confirms that printed terms and conditions of bidder are not applicable.					
11.	Bidder confirms that their offer is valid for period specified in BDS from Final/Extended due date of opening of Techno-commercial Bids.					
12.	As per requirement of tender, bidder (having status as Pvt. Ltd. or Limited company) must upload bid duly digitally signed on e-portal through class-3B digital signature (DS). In case, class of DS or name of employee or name of employer is not visible in the digitally signed documents, the bid digitally signed as submitted by the person shall be binding on the bidder.					
13.	Bidder confirms that (i) none of Directors (in Board of Director) of bidder is a relative of any Director (in Board of Director) of Owner or (ii) the bidder is not a firm in which any Director (in Board of Director) of Owner or their relative is not a partner.	<table border="1" style="width: 100%;"> <tr> <td style="text-align: center;">Confirmed</td> <td style="width: 50px;"></td> </tr> <tr> <td style="text-align: center;">Not confirmed</td> <td></td> </tr> </table>	Confirmed		Not confirmed	
Confirmed						
Not confirmed						
14.	All correspondence must be in ENGLISH language only					
15.	Bidder confirms the contents of this Tender Document have not been modified or altered by them. In case, it is found that the tender document has been modified / altered by the bidder, the bid submitted by them shall be liable for rejection.					
16.	Bidder confirms that all Bank charges associated with Bidder's Bank shall be borne by Bidder.					
17.	<u>No Deviation Confirmation:</u> It may be note that any 'deviation / exception' in any form may result in rejection of Bid. Therefore, Bidder confirms that they have not taken any 'exception / deviation' anywhere in the Bid. In case					

	<b>ELECTRICAL WORKS (SUPPLY &amp; ERECTION) FOR ALTERNATE POWER SUPPLY ARRANGEMENT OF VIKARMPUR GUEST HOUSE AT TALCHER FERTILIZERS LTD., ANGUL, ODISHA</b>	PC-183/E/ 8001 /S-III	0	
		DOC. NO.	REV	
		Page - 89 - of 115		

SI.	DESCRIPTION	BIDDER'S CONFIRMATION
	any 'deviation / exception' is mentioned or noticed, Bidder's Bid may be rejected.	
18.	<p>If Bidder becomes a successful Bidder and pursuant to the provisions of the Tender Document, award is given to them against subject Tender Document, the following Confirmation shall be automatically enforceable:</p> <p>"We agree and acknowledge that the Employer is entering into the Contract/Agreement solely on its own behalf and not on behalf of any other person or entity. In particular, it is expressly understood &amp; agreed that the Government of India is not a party to the Contract/Agreement and has no liabilities, obligations or rights there under. It is expressly understood and agreed that the Purchaser is authorized to enter into Contract/Agreement, solely on its own behalf under the applicable laws of India. We expressly agree, acknowledge and understand that the Purchaser is not an agent, representative or delegate of the Government of India. It is further understood and agreed that the Government of India is not and shall not be liable for any acts, omissions, commissions, breaches or other wrongs arising out of the Agreement. Accordingly, we hereby expressly waive, release and forego any and all actions or claims, including cross claims, VIP claims or counter claims against the Government of India arising out of the Agreement and covenants not to sue to Government of India as to any manner, claim, cause of action or things whatsoever arising of or under the Agreement."</p>	
19.	Bidder to ensure all documents as per tender including clause 11 of Section III and all Formats are included in their bid.	
20.	Bidder understands that Tender Document is not exhaustive. In case any activity though specifically not covered in description of 'Schedule of Rates' but is required to complete the work as per Scope of Work, Conditions of Contract, or any other part of Tender Document, the quoted rates will deemed to be inclusive of cost incurred for such activities unless otherwise specifically excluded. Bidder confirms to perform for fulfillment of the contract and completeness of the supplies in all respect within the scheduled time frame and quoted price.	
21.	<p>Bidder hereby confirms that they are not on 'Holiday' by OWNER or any of the JV partners of OWNER (viz. GAIL, RCF, CIL, FCIL) or Public Sector Project Management Consultant (like PDIL, EIL, Mecon only due to "poor performance" or "corrupt and fraudulent practices") or banned by Government department/ Public Sector on due date of submission of bid.</p> <p>Further, neither bidder nor their allied agency/(ies) (as defined in the Procedure for Action in case of Corrupt/Fraudulent/Collusive/Coercive Practices) are on banning list of TFL or any of the JV partner of OWNER viz. GAIL, RCF, CIL, FCIL.</p>	

	<b>ELECTRICAL WORKS (SUPPLY &amp; ERECTION) FOR ALTERNATE POWER SUPPLY ARRANGEMENT OF VIKARMPUR GUEST HOUSE AT TALCHER FERTILIZERS LTD., ANGUL, ODISHA</b>	PC-183/E/ 8001 /S-III	0	
		DOC. NO.	REV	
		Page - 90 - of 115		

SI.	DESCRIPTION	BIDDER'S CONFIRMATION
	<p>Bidder also confirms that they are not under any liquidation, court receivership or similar proceedings or 'bankruptcy'.</p> <p>In case it comes to the notice of TFL/PDIL that the bidder has given wrong declaration in this regard, the same shall be dealt as 'fraudulent practices' and action shall be initiated as per the Procedure for action in case of Corrupt/Fraudulent/ Collusive/ Coercive Practices.</p> <p>Further, Bidder also confirms that in case there is any change in status of the declaration prior to award of contract, the same will be promptly informed to TFL/PDIL by them.</p>	
22.	Bidder confirms that, in case of contradiction between the confirmations provided in this format and terms & conditions mentioned elsewhere in the offer, the confirmations given in this format shall prevail.	

Place:  
Date:

[Signature of Authorized Signatory of Bidder]  
Name:  
Designation:  
Seal:

	<b>ELECTRICAL WORKS (SUPPLY &amp; ERECTION) FOR ALTERNATE POWER SUPPLY ARRANGEMENT OF VIKARMPUR GUEST HOUSE AT TALCHER FERTILIZERS LTD., ANGUL, ODISHA</b>	PC-183/E/ 8001 /S-III	0	
		DOC. NO.	REV	
		Page - 91 - of 115		

**F-6**  
**ACKNOWLEDGEMENT CUM CONSENT LETTER**

(On receipt of tender document/information regarding the tender, Bidder shall acknowledge the receipt and confirm his intention to bid or reason for non-participation against the enquiry /tender through e-mail/fax to concerned executive in OWNER issued the tender, by filling up the Format)

To,

**M/s TALCHER FERTILZERS LIMITED  
NOIDA**

SUB:  
TENDER NO:

Dear Sir,

We hereby acknowledge receipt of a complete set of bidding document along with enclosures for subject item/job and/or the information regarding the subject tender.

- We intend to bid as requested for the subject item/job and furnish following details with respect to our quoting office:

Postal Address with Pin Code : .....

Telephone Number : .....

Fax Number : .....

Contact Person : .....

E-mail Address : .....

Mobile No. : .....

Date : .....

Seal/Stamp : .....

- We are unable to bid for the reason given below:

Reasons for non-submission of bid:

---

Agency's Name : .....



Signature : .....

Name : .....

Designation : .....

Date : .....

Seal/Stamp : .....

	<b>ELECTRICAL WORKS (SUPPLY &amp; ERECTION) FOR ALTERNATE POWER SUPPLY ARRANGEMENT OF VIKARMPUR GUEST HOUSE AT TALCHER FERTILIZERS LTD., ANGUL, ODISHA</b>	PC-183/E/ 8001/S-III	0	
		DOC. NO.	REV.	
		Page 92 of 120		

**F-7**  
**BIDDER'S EXPERIENCE**

To,  
**M/s TALCHER FERTILZERS LIMITED, NOIDA**

SUB:  
TENDER NO:

Sl. No	Description of the Services	LOA /WO No. and date	Full Postal Address & phone nos. of Client. <i>Name, designation and address of Engineer/ Officer-in-Charge (for cases other than purchase)</i>	Value of Contract/Order (Specify Currency Amount)	Date of Commencement of Services	Scheduled Completion Time (Months)	Date of Actual Completion	Reasons for delay in execution, if any
(1)	(2)	(3)	(5)	(6)	(7)	(8)	(9)	(10)

Place: [Signature of Authorized Signatory of Bidder]  
Date: Name:  
Designation:  
Seal:

**Note:**

- The documents (Work Order/DLOA/FOA, Completion certificate, Execution Certificate etc.) which have been referred/ specified/indicated/submitted in above tabulation format and/or along with bid shall be taken into consideration in reply to queries (if any) during evaluation of Bids. Hence, bidder in his own interest should invariably fill-up this format.



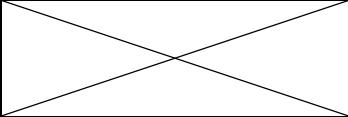

	<b>ELECTRICAL WORKS (SUPPLY &amp; ERECTION) FOR ALTERNATE POWER SUPPLY ARRANGEMENT OF VIKARMPUR GUEST HOUSE AT TALCHER FERTILIZERS LTD., ANGUL, ODISHA</b>	PC-183/E/ 8001 /S III	0	
		DOC. NO.	REV	
		Page 94 of 120		

4.0	Confirm that the price part as per Price Schedule format submitted with Bidding Document/ uploaded in case of e-bid.		
5.0	Confirm that annual reports for last three financial years & duly filled in <b>Format F-10</b> are enclosed in the offer for financial assessment (where financial criteria of BEC is applicable).		

Place:  
Date:

[Signature of Authorized Signatory of Bidder]  
Name:  
Designation:  
Seal:

	<b>ELECTRICAL WORKS (SUPPLY &amp; ERECTION) FOR ALTERNATE POWER SUPPLY ARRANGEMENT OF VIKARMPUR GUEST HOUSE AT TALCHER FERTILIZERS LTD., ANGUL, ODISHA</b>	PC-183/E/ 8001 /S III	0	
		DOC. NO.	REV	
		Page 95 of 120		

**F-9**  
**FORMAT FOR CERTIFICATE FROM BANK**  
**IF BIDDER'S WORKING CAPITAL IS INADEQUATE/NEGATIVE**  
 (To be provided on Bank's letter head)

Date:

To,

**M/s TALCHER FERTILIZERS LIMITED  
NOIDA**

Dear Sir,

This is to certify that M/s ..... (name of the bidder with address) (hereinafter referred to as Customer) is an existing customer of our Bank.

The Customer has informed that they wish to bid for OWNER's RFQ/Tender no. .... dated ..... for .....(Name of the supply/work/services/consultancy) and as per the terms of the said RFQ/Tender they have to furnish a certificate from their Bank confirming the availability of line of credit.

Accordingly M/s ..... (name of the Bank with address) confirms availability of line of credit to M/s ..... (name of the bidder) for at least an amount of Rs.

It is also confirmed that the net worth of the Bank is more than Rs. 100 Crores (or Equivalent USD) and the undersigned is authorized to issue this certificate.

Yours truly

for ..... (Name & address of Bank)

(Authorized signatory)

Name of the signatory:

Designation :

Stamp

	<b>ELECTRICAL WORKS (SUPPLY &amp; ERECTION) FOR ALTERNATE POWER SUPPLY ARRANGEMENT OF VIKARMPUR GUEST HOUSE AT TALCHER FERTILIZERS LTD., ANGUL, ODISHA</b>	PC-183/E/ 8001 /S III	0	
		DOC. NO.	REV	
		Page 96 of 120		

**F-10**

**FORMAT FOR CHARTERED ACCOUNTANT CERTIFICATE/ CERTIFIED PUBLIC  
ACCOUNTANT (CPA) FOR FINANCIAL CAPABILITY OF THE BIDDER**

We have verified the Audited Financial Statements and other relevant records of M/s..... (Name of the bidder) and certify the following:

**A. AUDITED ANNUAL TURNOVER\* OF PRECEDING THREE FINANCIAL YEARS:**

Year	Amount (Currency)
Year 1:	
Year 2:	
Year 3:	

**B. NETWORTH\* AS PER AUDITED FINANCIAL STATEMENT OF PRECEDING THREE FINANCIAL YEARS:**

Description	Year ____
	Amount (Currency)
1. Net Worth	

**C. WORKING CAPITAL\* AS PER AUDITED FINANCIAL STATEMENT OF PRECEDING FINANCIAL YEAR:**

Description	Year ____
	Amount (Currency)
1. Current Assets	
2. Current Liabilities	
3. Working Capital (Current Assets-Current liabilities)	

***\*Refer Instructions***

**Notes:**

- (i) It is further certified that the above mentioned applicable figures are matching with the returns filed with Registrar of Companies (ROC) [Applicable only in case of Indian Companies]
- (ii) We confirm that above figures after referring instructions at page 2 of 2 of Format F-10.
- (iii) Practicing Chartered Accountants shall generate Unique Document Identification Number (UDIN) for all certificates issued by them.

	<b>ELECTRICAL WORKS (SUPPLY &amp; ERECTION) FOR ALTERNATE POWER SUPPLY ARRANGEMENT OF VIKARMPUR GUEST HOUSE AT TALCHER FERTILIZERS LTD., ANGUL, ODISHA</b>	PC-183/E/ 8001 /S III	0	
		DOC. NO.	REV	
		Page 97 of 120		

Name of Audit Firm:

Chartered Accountant/CPA

Date: Designation:

Membership No.:

[Signature of Authorized Signatory]



Name:

Seal:

UDIN

#### Instructions for Format F-10:

1. The financial year would be the same as one normally followed by the bidder for its Annual Report.
2. The bidder shall provide the audited annual financial statements as required for this Tender document. Failure to do so would result in the Proposal being considered as non-responsive.
3. For the purpose of this Tender document:
  - (i) **Annual Turnover** shall be "Sale Value/ Operating Income"
  - (ii) **Working Capital** shall be "Current Assets less Current liabilities" and
  - (iii) **Net Worth** shall be Paid up share capital plus Free Reserves & Surplus less accumulated losses, deferred expenditure and miscellaneous expenditure not written off, if any.
4. **Above figures shall be calculated after considering the qualification, if any, made by the statutory auditor on the audited financial statements of the bidder including quantified financial implication.**
5. This certificate is to be submitted on the letter head of Chartered Accountant/CPA.

	<b>ELECTRICAL WORKS (SUPPLY &amp; ERECTION) FOR ALTERNATE POWER SUPPLY ARRANGEMENT OF VIKARMPUR GUEST HOUSE AT TALCHER FERTILIZERS LTD., ANGUL, ODISHA</b>	PC-183/E/ 8001/S III	0	
		DOC. NO.	REV.	
		Page 98 of 120		



**F-11  
BIDDER'S QUERIES FOR PRE BID MEETING**

To,  
M/s TALCHER FERTILIZERS LIMITED  
Sub :  
Tender No :

SL. NO.	REFERENCE OF BIDDING DOCUMENT				BIDDER'S QUERY	OWNER'S REPLY
	SEC. NO.	Page No.	Clause No.	Subject		

**NOTE: The Pre-Bid Queries may be sent by fax and also by e-mail before due date for receipt of Bidder's queries.**

**SIGNATURE OF BIDDER:** \_\_\_\_\_  
**NAME OF BIDDER :** \_\_\_\_\_

	<b>ELECTRICAL WORKS (SUPPLY &amp; ERECTION) FOR ALTERNATE POWER SUPPLY ARRANGEMENT OF VIKARMPUR GUEST HOUSE AT TALCHER FERTILIZERS LTD., ANGUL, ODISHA</b>	PC-183/E/ 8001 /S III	0	
		DOC. NO.	REV.	
		Page 99 of 120		

**F-12**  
**E-Banking Mandate Form**  
 (To be issued on bidder's letter head)

1. Vendor/customer Name :
2. Vendor/customer Code:
3. Vendor/customer Address:
4. Vendor/customer e-mail id:
5. Particulars of bank account
  - a) Name of Bank
  - b) Name of branch
  - c) Branch code:
  - d) Address:
  - e) Telephone number:
  - f) Type of account (current/saving etc.)
  - g) Account Number:
  - h) RTGS IFSC code of the bank branch
  - i) NEFT IFSC code of the bank branch
  - j) 9 digit MICR code

I/We hereby authorize TALCHER FERTILZERS LIMITED to release any amount due to me/us in the bank account as mentioned above. I/We hereby declare that the particulars given above are correct and complete. If the transaction is delayed or lost because of incomplete or incorrect information, we would not hold the TALCHER FERTILZERS LIMITED responsible.

(Signature of vendor/customer)

**BANK CERTIFICATE**

We certify that ----- has an Account no. ----- with us and we confirm that the details given above are correct as per our records.

Bank stamp

Date

(Signature of authorized officer of bank)



**ELECTRICAL WORKS (SUPPLY & ERECTION)  
FOR  
ALTERNATE POWER SUPPLY ARRANGEMENT OF  
VIKARMPUR GUEST HOUSE  
AT TALCHER FERTILIZERS LTD., ANGUL, ODISHA**

PC-183/E/ 8001 /S III

0

DOC. NO.

REV



Page 100 of 120

**F-13**

**INTEGRITY PACT**

**Pre-signed Integrity Pact**



# **INTEGRITY PACT**

## INTEGRITY PACT

### INTRODUCTION:

TFL as one of its endeavour to maintain and foster most ethical and corruption free business environment, have decided to adopt the Integrity Pact, a tool developed by the Transparency International, to ensure that all activities and transactions between the Company (TFL) and its Counterparties (Bidders, Contractors, Vendors, Suppliers, Service Providers/Consultants etc.) are handled in a fair and transparent manner, completely free of corruption.

Considering the above, the details mentioned at attached Annexure-1 are applicable as stated in Instruction to Bidders of Bid Document in addition to the existing stipulation regarding Corrupt and Fraudulent Practices.

The attached copy of the Integrity Pact at Annexure - 2 shall be included in the Bid submitted by the bidder (to be executed by the bidder for all tenders of value Rs. 1 (One) crore and above). In case a bidder does not sign the Integrity Pact, his bid shall be liable for rejection.



## ANNEXURE-1

Bidder is required to sign the Integrity Pact with TFL as per format & terms and conditions enclosed with tender. In case a bidder does not sign the Integrity Pact, his bid shall be liable for rejection.

### I COMMITMENTS AND OBLIGATIONS OF THE "COUNTERPARTY"

- a) The Counterparty, directly or indirectly (through agent, consultant, advisor, etc.), shall not pay any bribe/ influence or give undue/ unlawful benefit to anyone to gain undue advantage in dealing with TFL.
- b) The Counterparty will not engage in collusion of any kind including price fixation etc. with other Counterparts.
- c) The counterparty will not pass TFL's confidential information to any third party unless specifically authorized by TFL in writing.
- d) The Counterparties shall promote and observe best ethical practices within their respective organizations.
- e) The Counterparty shall inform the Independent External Monitor.
  - i) If it received any demand, directly or indirectly, for a bribe/ favour or any illegal gratification/ payment / benefit;
  - ii) If it comes to know of any unethical or illegal payment / benefit;
  - iii) If it makes any payment to any TFL associate.
- f) The Counterparty shall not make any false or misleading allegations against TFL or its associates.

### II VIOLATIONS & CONSEQUENCES:

- a) If a Counterparty commits a violation of its Commitments and Obligations under the Integrity Pact Programme during bidding process, their entire Earnest Money Deposit/ Bid Security, would be forfeited and in addition, action shall be taken as per "Procedure for action in case Corrupt /Fraudulent/ Collusive/Coercive Practices"
- b) In case of violation of the Integrity pact by Counterparty after award of the Contract, TFL shall be entitled to terminate the Contract. Further, TFL would forfeit the security deposits/ Contract Performance Bank Guarantee and in addition, action shall be taken as per "Procedure for action in case Corrupt /Fraudulent/ Collusive/Coercive Practices"



### INDEPENDENT EXTERNAL MONITORS (IEMS)

Presently the panel consisting of the following Independent External Monitors (IEMs) have been appointed by TFL, in terms of Integrity Pact (IP) which forms part of TFL Tenders / Contracts.

- i) Shri Anjan Kumar Banerjee (Email ID: [banerjeeanjan@gmail.com](mailto:banerjeeanjan@gmail.com))
- ii) Shri Atul Sobti (Email ID: [sobtiatul@gmail.com](mailto:sobtiatul@gmail.com))

This panel is authorised to examine / consider all references made to it under this tender. The bidder(s), in case of any dispute(s) / complaint(s) pertaining to this tender may raise the issue either with the designated tender issuing officer or Nodal Officer (presently Sh. S. Dasgupta, DGM (C&P) – Email: [sdasgupta@gail.co.in](mailto:sdasgupta@gail.co.in)) in TFL or directly with the IEMs on the panel or IEM c/o Chief Vigilance Officer, Rashtriya Chemicals and Fertilizers Ltd., Priyadarshini Building, Eastern Express Highway, Sion, Mumbai Maharashtra, 400022.

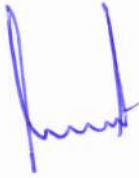



**INTEGRITY PACT**

(To be executed on plain paper)

Between TFL (India) Limited, a Government of India Public Sector, (here-in-after referred to as "Principal").

**AND**

\_\_\_\_\_ (here-in-after referred to as "The Bidder/ Contractor").

(Principal and the Bidder / Contractor are here-in-after are referred to individually as "Party" or collectively as "Parties").

**PREAMBLE**

The Principal intends to award under laid down organizational procedures, contract/s for \_\_\_\_\_. The Principal values full compliance with all relevant laws of land rules, regulations, and economic use of resources and of fairness /transparency in its relations with its Bidder (s) and/or Contractor (s).

In order to achieve these goals, the Principal will appoint Independent External Monitors (IEMs) who will monitor the tender process and the execution of the contract for compliance with the principles mentioned above.

**Section 1 – Commitments of the Principal**

1. The Principal commits itself to take all measures necessary to prevent corruption and to observe the following Principles:-
  - i) No employee of the Principal, personally or through family members, will in connection with the tender for, or the execution of a contract, demand, take a promise for or accept, for self or for a third person, any material or immaterial benefit which the person is not legally entitled to.
  - ii) The Principal will, during the tender process treat all Bidder(s) with equity and reasons. The Principal will in particular, before and during the tender process, provide to all Bidder(s) the same information and will not provide to any Bidder(s) confidential / additional information through which the Bidder(s) could obtain an advantage in relation to the tender process or the contract execution.



- iii) The Principal will exclude from the process all known prejudiced persons.
2. If the Principal obtains information on the conduct of any of its employees which is a criminal offence under the Indian Penal Code (IPC) / Prevention of Corruption Act (PC Act), or if there be a substantive suspicion in this regard, the Principal will inform the Chief Vigilance Officers and in addition can initiate disciplinary actions.

**Section 2 – Commitments of the Bidder (s)/Contractor (s)**

1. The Bidder(s) / Contractor(s) commits themselves to take all measures necessary to prevent corruption. The Bidder(s) / Contractor(s) commits themselves to observe the following principles during participation in the tender process and during the contract execution:
- i) The Bidder (s) / Contractor (s) will not, directly or through any other person or firm, offer, promise or give to any of the Principal's employees involved in the tender process or the execution of the contract or to any third person any material or other benefit which he / she is not legally entitled to, in order to obtain in exchange any advantage of any kind whatsoever during the tender process or during the execution of the contract.
  - ii) The Bidder (s) / Contractor (s) will not enter with other Bidders into any undisclosed agreement or understanding, whether formal or informal. This applies in particular to prices, specifications, certifications, subsidiary contracts, submission or non-submission of bids or any other action to restrict competitiveness or to introduce cartelisation in the bidding process.
  - iii) The Bidder (s) / Contractor (s) will not commit any offence under the relevant IPC/PC Act; further, the Bidder (s) / Contractor (s) will not use improperly, for purposes of competition or personal gain, or pass on to others, any information or document provided by the Principal as part of the business relationship, regarding plans, technical proposals and business details, including information contained or transmitted electronically.
  - iv) The Bidder (s)/ Contractor (s) of foreign origin shall disclose the name and address of the Agents/ representatives in India, if any. Similarly, the Bidder (s)/ Contractor (s) of Indian Nationality shall furnish the name and address of the foreign principals, if any. Further, all the payments made to the Indian agent/ representative have to be in India Rupees only.
  - v) The Bidder (s) / Contractor (s) will, when presenting their bid, disclose any and all payments made, is committed to or intends to make to agents,





brokers or any other intermediaries in connection with the award of the contract.

- vi) Bidder(s) / Contractor(s) who have signed the Integrity Pact shall not approach the Courts while representing the matter to IEMs and shall wait for their decision in the matter.
2. The Bidder(s)/ Contractor(s) shall not instigate third person to commit offences outlined above or be an accessory to such offences.

**Section 3 – Disqualification from tender process and exclusion from future contracts**

If the Bidder (s) / Contractor (s), before award or during execution has committed a transgression through a violation of Section 2, above or in any other form such as to put their reliability or credibility in question, the Principal is entitled to disqualify the Bidder (s) / Contractor (s) from the tender process or take action as per provisions of "Procedure for action in case Corrupt /Fraudulent/ Collusive/Coercive Practices".

**Section 4 – Compensation for Damages**

1. If the Principal has disqualified the Bidder (s) from the tender process prior to the award according to Section 3, the Principal is entitled to demand and recover the damages equivalent to Earnest Money Deposit / Bid Security.
2. If the Principal has terminated the contract according to Section 3, or if the Principal is entitled to terminate the contract according to Section 3, the Principal shall be entitled to demand and recover from the Contractor liquidated damages equal to the Contract Value or the amount equivalent to Performance Bank Guarantee.

**Section 5 – Previous transgression**

1. The Bidder declares that no previous transgression occurred in the last three years, with any other Company in any country conforming to the anti-corruption approach or with any Public Sector Enterprise in India that could justify his exclusion from the tender process.
2. If the Bidder makes incorrect statement on this subject, he can be disqualified from the tender process or actions can be taken as per provisions of "Procedure for action in case Corrupt /Fraudulent/ Collusive/Coercive Practices"



### **Section 6 – Equal treatment to all Bidders / Contractors / Subcontractors**

1. In case of Sub-Contracting, the Principal Contractor shall take the responsibility of the adoption of Integrity Pact by the Sub-contractor.
2. The Principal will enter into agreements with identical conditions as this one with all Bidders and Contractors.
3. The Principal will disqualify from the tender process all bidders who do not sign this Pact or violate its provisions.

### **Section 7 – Criminal charges against violating Bidder (s) / Contractor (s) / Sub-contractor (s)**

If the Principal obtains knowledge of conduct of a Bidder, Contractor or Subcontractor, or of an employee or a representative or an associate of a Bidder, Contractor or Subcontractor which constitutes corruption, or if the Principal has substantive suspicion in this regard, the Principal will inform the same to the Chief Vigilance Officer.

### **Section 8 –Independent External Monitor / Monitors**

1. The Principal appoints competent and credible Independent External Monitor for this Pact after approval by Central Vigilance Commission. The task of the Monitor is to review independently and objectively, whether and to what extent the parties comply with the obligations under this agreement.
2. The Monitor is not subject to instructions by the representatives of the parties and performs his/her functions neutrally and independently. The Monitor would have access to all Contract documents, whenever required. It will be obligatory for him/ her to treat the information and documents of the Bidders/ Contractors as confidential. He/she reports to the MD, TFL.
3. The Bidder (s)/ Contractor (s) accepts that the Monitor has the right to access without restriction to all Project documentation of the Principal including that provided by the Contractor. The Contractor will also grant the Monitor, upon his/her request and demonstration of a valid interest, unrestricted and unconditional access to their project documentation. The same is applicable to Sub-contractors.
4. The Principal will provide to the Monitor sufficient information about all meetings among the parties related to the Project provided such meetings could have an impact on the contractual relations between the Principal and the Contractor. The parties offer to the Monitor the option to participate in such meetings.
5. As soon as the Monitor notices, or believes to notice, a violation of this agreement, he/she will so inform the Management of the Principal and request





the Management to discontinue or to take corrective action, or to take other relevant action. The monitor can in this regard submit non-binding recommendations. Beyond this, the Monitor has no right to demand from the parties that they act in a specific manner, refrain from action or tolerate action.

6. The Monitor will submit a written report to the MD, TFL within 10 days as far as possible from the date of reference or intimation to him by the 'Principal' and, should the occasion arise, submit proposals for correcting problematic situations.
7. If the Monitor has reported to the MD, TFL, a substantiated suspicion of an offence under relevant IPC/PC Act, and the MD, TFL has not, within reasonable time, taken visible action to proceed against such offence or reported it to the Chief Vigilance Officer, the Monitor may also transmit this information directly to the Central Vigilance Commissioner.
8. The word 'Monitor' would include both singular and plural.
9. In case of any complaints referred under IP Program, the role of IEMs is advisory and would not be legally binding and it is restricted to resolving the issues raised by an intending bidder regarding any aspect of the tender which allegedly restricts competition or bias towards some bidder.

#### **Section 9 – Pact Duration**

This Pact begins when both parties have legally signed it. It expires for the Contractor 12 months after the last payment under the respective contract, and for all other Bidders 6 months after the contract has been awarded. Any violation to the same would entail disqualification of the bidders and exclusion from future business dealing.

If any claim is made / lodged during this time, the same shall be binding and continue to be valid despite the lapse of this pact as specified above, unless it is discharged/determined by the MD, TFL.

#### **Section 10 – Miscellaneous provisions**

1. This agreement is subject to Indian Law. Place of performance and exclusive jurisdiction is the Registered Office of the Principal, i.e. New Delhi.
2. Changes and supplements as well as termination notices, if any, need to be made in writing. Side agreements have not been made.
3. If the Contractor / Bidder is a partnership concern or a consortium, this agreement must be signed by all partners or consortium members.



4. Should one or several of the provisions of this agreement turn out to be invalid, the remainder of this agreement shall remain valid. In this case, the parties will strive to come to an agreement to their original intentions in such a case.
5. Issues like warranty / guarantee, etc. shall be outside the purview of IEMs.
6. In the event of any contradiction between the Integrity Pact and its Annexure, the Clause in Integrity Pact will prevail.



-----  
 (For & on Behalf of Principal)

ए. एस. दासगुप्ता / S. DASGUPTA

उप महासंचालक (संविदा एवं प्रत्येक) / Dy. General Manager (C&P)  
 ताल्चर फर्टिलाइजर्स लिमिटेड / Talcher Fertilizers Ltd.  
 जीटीपार्क पीएआरसी बिल्डिंग / GTI PARC Building  
 प्लॉट नं० 24, सेक्टर-16ए, नोएडा-201301 (उ.प्र.)  
 Plot No. 24, Sec.-16A, Noida-201 301(U.P.)

(Office Seal)

-----  
 (For & on Behalf of Bidder/Contractor)

(Office Seal)

Place -----



Date -----

Witness 1:  
 (Sign, Name & Address)  
 [FOR PRINCIPAL]

Seogam (Sura Deogam)  
 Talcher Fertilizers Limited (T.F.L.), Plot No. 24,  
 Sector-16A, Film City, Noida (U.P.) - 201301

Witness 2:  
 (Sign, Name & Address)  
 [FOR BIDDER / CONTRACTOR]

.....  
 .....  
 .....

	<b>ELECTRICAL WORKS (SUPPLY &amp; ERECTION) FOR ALTERNATE POWER SUPPLY ARRANGEMENT OF VIKARMPUR GUEST HOUSE AT TALCHER FERTILIZERS LTD., ANGUL, ODISHA</b>	PC-183/E/ 8001 /S III	0	
		DOC. NO.	REV	
		Page 101 of 120		

F-14

**INDEMNITY BOND**

WHEREAS TALCHER FERTILIZERS LIMITED (hereinafter referred to as “TFL”) which expression shall, unless repugnant to the context include its successors and assigns, having its registered office at Plot 2/H, Kalpana Area, BJB Nagar, Khorda, Bhubaneswar – 751014 has entered into a contract with M/s\*..... (hereinafter referred to as the “Contractor”) which expression shall unless repugnant to the context include its representatives, successors and assigns, having its registered office at \* ..... and on the terms and conditions as set out, inter-alia in the ..... [*mention the work order/LOA/Tender No.*]and various documents forming part thereof, hereinafter collectively referred to as the ‘CONTRACT’ which expression shall include all amendments, modifications and / or variations thereto.

TFL has also advised the Contractor to execute an Indemnity Bond in general in favour of TFL indemnifying TFL and its employees and Directors including Independent Directors from all consequences which may arise out of any prospective litigation or proceedings filed or may be initiated by any third party, including any Banker / financial institution / worker(s) / vendor(s)/ subcontractor(s) etc. who may have been associated or engaged by the Contractor directly or indirectly with or without consent of TFL for above works.

NOW, THEREFORE, in consideration of the promises aforesaid, the Contractor hereby irrevocably and unconditionally undertakes to indemnify and keep indemnified TFL and all its employees, Directors, including Independent Directors, from and against all/any claim(s), damages, loss, which may arise out of any litigations/ liabilities that may be raised by the Contractor or any third party against TFL under or in relation to this contract. The Contractor undertakes to compensate and pay to TFL and/or any of its employees, Directors including Independent Directors, forth with on demand without any protest the amount claimed by TFL for itself and for and on behalf of its employees, Directors including Independent Directors together with direct/indirect expenses including all legal expenses incurred by them or any of them on account of such litigation or proceedings.

AND THE CONTRACTOR hereby further agrees with TFL that:

- (i) This Indemnity shall remain valid and irrevocable for all claims of TFL and/or any of its employees and Directors including Independent Directors arising out of said contract with respect to any such litigation / court case for which TFL and/or its employees and Directors including Independent Directors has been made party until now or here-in-after.
- (ii) This Indemnity shall not be discharged/ revoked by any change/ modification/ amendment/ assignment of the contract or any merger of the Contractor with other entity or any change in the constitution/structure of the Contractor’s firm/Company or any

	<b>ELECTRICAL WORKS (SUPPLY &amp; ERECTION) FOR ALTERNATE POWER SUPPLY ARRANGEMENT OF VIKARMPUR GUEST HOUSE AT TALCHER FERTILIZERS LTD., ANGUL, ODISHA</b>	PC-183/E/ 8001 /S III	0	
		DOC. NO.	REV	
		Page 102 of 120		

conditions thereof including insolvency etc. of the Contractor, but shall be in all respects and for all purposes binding and operative until any/all claims for payment of TFL are settled by the Contractor and/or TFL discharges the Contractor in writing from this Indemnity.

The undersigned has full power to execute this Indemnity Bond for and on behalf of the Contractor and the same stands valid.

SIGNED BY :

For [ Contractor ]

*Authorised Representative*

Place:

Dated:

Witnesses:

1.

2



	<b>ELECTRICAL WORKS (SUPPLY &amp; ERECTION) FOR ALTERNATE POWER SUPPLY ARRANGEMENT OF VIKARMPUR GUEST HOUSE AT TALCHER FERTILIZERS LTD., ANGUL, ODISHA</b>	PC-183/E/ 8001 /S III	0	
		DOC. NO.	REV	
		Page 103 of 120		

**F-15**

**POWER OF ATTORNEY (POA)  
(to be submitted on the Non-Judicial stamp paper / Company's Letter Head)**

TENDER NO: \_\_\_\_\_ dated \_\_\_\_\_

Description of work:

Name of Bidder: \_\_\_\_\_



"The undersigned \_\_\_\_\_ (Name of LEGAL PERSON, i.e. CEO/C&MD/Company Secretary/Partners) is lawfully authorized to issue this POA\* on behalf of the company M/s \_\_\_\_\_ (Name of bidder) whose \_\_\_\_\_ registered \_\_\_\_\_ address \_\_\_\_\_ is \_\_\_\_\_ and does hereby appoint Mr./Ms \_\_\_\_\_ (name of authorized person signing the bid document) \_\_\_\_\_ (Designation) of M/s \_\_\_\_\_ (Name of bidder) whose signature appears below to be the true and lawful attorney/(s) and authorize him/her to sign the bid (both physically & digitally on CPP Portal), conduct negotiation, sign contracts and execute all the necessary matter related thereto, in the name and on behalf of the company in connection with the tender no. \_\_\_\_\_.

The signature of the authorized person/(s) herein constitutes unconditional obligations of M/s \_\_\_\_\_ (Name of bidder).

This Power of Attorney (POA) shall remain valid and in full force and effect before we withdraw it in writing (by fax, or mail or post). All the documents signed (within the period of validity of the Power of Attorney) by the authorized person herein shall not be invalid because of such withdrawal.

(\*)

- (I) In case of a single Bidder, the power of Attorney shall be issued as per the constitution of the bidder as below.
- e) **In case of Proprietorship:** By Proprietor
  - f) **In case of Partnership:** by all Partners or Managing Partner.
  - g) **In case of Limited Liability Partnership:** by any bidder's employee authorized in terms of Deed of LLP.
  - h) **In case of Public /Limited Company:** POA in favour of authorized employee(s) by Board of Directors through Board Resolution or by the designated officer authorized by Board to do so. Such Board Resolution should be duly countersigned by Company Secretary / MD / CMD / CEO.

	<b>ELECTRICAL WORKS (SUPPLY &amp; ERECTION) FOR ALTERNATE POWER SUPPLY ARRANGEMENT OF VIKARMPUR GUEST HOUSE AT TALCHER FERTILIZERS LTD., ANGUL, ODISHA</b>	PC-183/E/ 8001 /S III	0	
		DOC. NO.	REV	
		Page 104 of 120		

(II) ~~In case of a Consortium, Power of Attorney shall be issued both by leader as well as Consortium Member(s) of the Consortium as per procedure defined herein above in favour of employee of Leader Consortium.~~

SIGNATURE OF THE LEGAL PERSON

\_\_\_\_\_

(Name of person with Company seal)

SIGNATURE OF THE AUTHORIZED PERSON  
(FOR SIGNING THE BID)



\_\_\_\_\_

(Signature)

Name of person: \_\_\_\_\_

E-mail id: \_\_\_\_\_

DSC (Digital Signature Certificate) No.: \_\_\_\_\_

	<b>ELECTRICAL WORKS (SUPPLY &amp; ERECTION) FOR ALTERNATE POWER SUPPLY ARRANGEMENT OF VIKARMPUR GUEST HOUSE AT TALCHER FERTILIZERS LTD., ANGUL, ODISHA</b>	PC-183/E/ 8001 /S III	0	
		DOC. NO.	REV	
		Page 105 of 120		

**F-16  
PROFORMA FOR CONTRACT AGREEMENT**



DLOA No. .... dated -----  
-

**TFL's PAN No. ....**

Contract Agreement for the work of ----- of TALCHER FERTILIZERS LIMITED made on ----- between (Name and Address)-----, hereinafter called the "CONTRACTOR" (which term shall unless excluded by or repugnant to the subject or context include its successors and permitted assignees) of the one part and TALCHER FERTILIZERS LIMITED hereinafter called the "EMPLOYER" (which term shall, unless excluded by or repugnant to the subject or context include its successors and assignees) of the other part.

**WHEREAS**

- A. The EMPLOYER being desirous of having provided and executed certain work mentioned, enumerated or referred to in the Tender Documents including Letter Inviting Tender, General Tender Notice, General Conditions of Contract, Special Conditions of Contract, Specifications, Drawings, Plans, Time Schedule of completion of jobs, Schedule of Rates, Agreed Variations, other documents has called for Tender.
- B. The CONTRACTOR has inspected the SITE and surroundings of WORK specified in the Tender Documents and has satisfied himself by careful examination before submitting his tender as to the nature of the surface, strata, soil, sub-soil and ground, the form and nature of site and local conditions, the quantities, nature and magnitude of the work, the availability of labour and materials necessary for the execution of work, the means of access to SITE, the supply of power and water thereto and the accommodation he may require and has made local and independent enquiries and obtained complete information as to the matters and thing referred to, or implied in the tender documents or having any connection therewith and has considered the nature and extent of all probable and possible situations, delays, hindrances or interferences to or with the execution and completion of the work to be carried out under the CONTRACT, and has examined and considered all other matters, conditions and things and probable and possible contingencies, and generally all matters incidental thereto and ancillary thereof affecting the execution and completion of the WORK and which might have influenced him in making his tender.
- C. The Tender Documents including the Notice Letter Inviting Tender, General Conditions of Contract, Special Conditions of Contract, Schedule of Rates, General Obligations, SPECIFICATIONS, DRAWINGS, PLANS, Time Schedule for completion of Jobs, Letter of Acceptance of Tender and any statement of agreed variations with its enclosures copies of which are hereto annexed form part of this CONTRACT though separately set out herein and are included in the expression "CONTRACT" wherever herein used.

	<b>ELECTRICAL WORKS (SUPPLY &amp; ERECTION) FOR ALTERNATE POWER SUPPLY ARRANGEMENT OF VIKARPUR GUEST HOUSE AT TALCHER FERTILIZERS LTD., ANGUL, ODISHA</b>	PC-183/E/ 8001 /S III	0	
		DOC. NO.	REV	
		Page 106 of 120		

**AND WHEREAS**

The EMPLOYER accepted the Tender of the CONTRACTOR for the provision and the execution of the said WORK at the rates stated in the schedule of quantities of the work and finally approved by EMPLOYER (hereinafter called the "Schedule of Rates") upon the terms and subject to the conditions of CONTRACT.

**NOW THIS AGREEMENT WITNESSETH AND IT IS HEREBY AGREED AND DECLARED AS FOLLOWS:-**

1. In consideration of the payment to be made to the CONTRACTOR for the WORK to be executed by him, the CONTRACTOR hereby covenants with EMPLOYER that the CONTRACTOR shall and will duly provide, execute and complete the said work and shall do and perform all other acts and things in the CONTRACT mentioned or described or which are to be implied there from or may be reasonably necessary for the completion of the said WORK and at the said times and in the manner and subject to the terms and conditions or stipulations mentioned in the contract.



2. In consideration of the due provision execution and completion of the said WORK, EMPLOYER does hereby agree with the CONTRACTOR that the EMPLOYER will pay to the CONTRACTOR the respective amounts for the WORK actually done by him and approved by the EMPLOYER at the Schedule of Rates and such other sum payable to the CONTRACTOR under provision of CONTRACT, such payment to be made at such time in such manner as provided for in the CONTRACT.

**A N D**

3. In consideration of the due provision, execution and completion of the said WORK the CONTRACTOR does hereby agree to pay such sums as may be due to the EMPLOYER for the services rendered by the EMPLOYER to the CONTRACTOR, such as power supply, water supply and others as set for in the said CONTRACT and such other sums as may become payable to the EMPLOYER towards the controlled items of consumable materials or towards loss, damage to the EMPLOYER'S equipment, materials construction plant and machinery, such payments to be made at such time and in such manner as is provided in the CONTRACT.

It is specifically and distinctly understood and agreed between the EMPLOYER and the CONTRACTOR that the CONTRACTOR shall have no right, title or interest in the SITE made available by the EMPLOYER for execution of the works or in the building, structures or work executed on the said SITE by the CONTRACTOR or in the goods, articles, materials etc., brought on the said SITE (unless the same specifically belongs to the CONTRACTOR) and the CONTRACTOR shall not have or deemed to have any lien whatsoever charge for unpaid bills will not be entitled to assume or retain possession or control of the SITE or structures and the EMPLOYER shall have an absolute and unfettered right to take full possession of SITE and to remove the CONTRACTOR, their servants, agents and materials belonging to the CONTRACTOR and lying on the SITE.



	<b>ELECTRICAL WORKS (SUPPLY &amp; ERECTION) FOR ALTERNATE POWER SUPPLY ARRANGEMENT OF VIKARMPUR GUEST HOUSE AT TALCHER FERTILIZERS LTD., ANGUL, ODISHA</b>	PC-183/E/ 8001 /S III	0	
		DOC. NO.	REV	
		Page 107 of 120		

The CONTRACTOR shall be allowed to enter upon the SITE for execution of the WORK only as a licensee simpliciter and shall not have any claim, right, title or interest in the SITE or the structures erected thereon and the EMPLOYER shall be entitled to terminate such license at any time without assigning any reason.

The materials including sand, gravel, stone, loose, earth, rock etc., dug up or excavated from the said SITE shall, unless otherwise expressly agreed under this CONTRACT, exclusively belong to the EMPLOYER and the CONTRACTOR shall have no right to claim over the same and such excavation and materials should be disposed off on account of the EMPLOYER according to the instruction in writing issued from time to time by the ENGINEER-IN-CHARGE.

In Witness whereof the parties have executed these presents in the day and the year first above written.

Signed and Delivered for and on behalf of EMPLOYER

Signed and Delivered for and on behalf of the CONTRACTOR.

TALCHER FERTILIZERS LIMITED  
\_\_\_\_\_

NAME OF CONTRACTOR  
\_\_\_\_\_

Date : \_\_\_\_\_

Date : \_\_\_\_\_

Place: \_\_\_\_\_

Place: \_\_\_\_\_



**IN PRESENCE OF TWO WITNESSES**

1. \_\_\_\_\_

1. \_\_\_\_\_

2. \_\_\_\_\_

2. \_\_\_\_\_



	<b>ELECTRICAL WORKS (SUPPLY &amp; ERECTION) FOR ALTERNATE POWER SUPPLY ARRANGEMENT OF VIKARMPUR GUEST HOUSE AT TALCHER FERTILIZERS LTD., ANGUL, ODISHA</b>	PC-183/E/ 8001 /S III	0	
		DOC. NO.	REV	
		Page 108 of 120		

**F-17**

**FREQUENTLY ASKED QUESTIONS (FAQs)**

SL.NO.	QUESTION	ANSWER
1.0	Can any vendor quote for subject Tender?	Yes. A Vendor has to meet Bid Evaluation Criteria given under Section II of Tender document in addition to other requirements.
2.0	Should the Bid Evaluation Criteria documents be attested?	Yes. Please refer Section II of Tender document
3.0	Is attending Pre-Bid Meeting mandatory.	No. Refer Clause No. 17 of Instruction to Bidders of Tender Document. However attending Pre Bid Meeting is recommended to sort out any issue before submission of bid by a Bidder.
4.0	Can a vendor submit more than 1 offer?	No. Please refer Clause No. 4 of "Instruction to Bidders" of Tender Document.
5.0	Is there any Help document available for e-Tender.	Yes. Refer Annexure III to "Instruction to Bidders" of Tender Document and FAQs as available on OWNER E-Tender portal.
6.0	Are there are any benefits available to Start-ups?	Refer Clause No. 50 of Instructions to Bidders of Tender Document
7.0	Are there are any MSE (Micro & Small Enterprises) benefits available?	Refer Clause No. 40 of Instructions to Bidders of Tender Document.

All the terms and conditions of Tender remain unaltered.

	<b>ELECTRICAL WORKS (SUPPLY &amp; ERECTION) FOR ALTERNATE POWER SUPPLY ARRANGEMENT OF VIKARMPUR GUEST HOUSE AT TALCHER FERTILIZERS LTD., ANGUL, ODISHA</b>	PC-183/E/ 8001 /S III	0	
		DOC. NO.	REV	
		Page 109 of 120		

F-18

**NOT APPLICABLE FOR THIS TENDER**



**~~POLICY FOR PROVIDING PREFERENCE TO DOMESTICALLY MANUFACTURED  
IRON & STEEL PRODUCTS IN GOVERNMENT PROCUREMENT  
(TO BE SUBMITTED ON BIDDER'S LETTERHEAD)~~**

**SELF-CERTIFICATE**

~~This has reference to "Policy for providing Preference to Domestically Manufactured Iron & Steel Products in Government Procurement" issued by Ministry of Steel, Govt. of India, vide their revised notification "The Gazette of India, Notification No. 385 (E) dated 29.05.2019".~~

~~We confirm that we will obtain Affidavit of Self Certification of Domestic value addition in Iron & Steel Products from manufacturer before supply of iron and steel products required under the tender/bidding document.~~

Sign & Stamp of bidder

	<b>ELECTRICAL WORKS (SUPPLY &amp; ERECTION) FOR ALTERNATE POWER SUPPLY ARRANGEMENT OF VIKARMPUR GUEST HOUSE AT TALCHER FERTILIZERS LTD., ANGUL, ODISHA</b>	PC-183/E/ 8001 /S III	0	
		DOC. NO.	REV	
		Page 110 of 120		

**NOT APPLICABLE FOR THIS TENDER**

**F-19**

**Format for Undertaking from TPIA**  
(on TPIA letter head duly stamped & signed)

Ref.: \_\_\_\_\_ Date: \_\_\_\_\_

To,

Talcher Fertilizers Limited

Dear Sir,

**Subject: ~~Verification and certification of documents pertaining to Technical Bid Evaluation Criteria (BEC)~~**

**Ref: \_\_\_\_\_ Tender no. .... for .....**

~~M/s. .... having Registered office at ..... intend to participate in above referred tender of Talcher Fertilizers Limited having registered office at Plot 2/H, Kalpana Area, BJB Nagar, Khordha, Bhubaneswar-751014, Odisha~~

~~The tender conditions stipulates that the BIDDER shall submit Documents pertaining to Technical Bid Evaluation Criteria (BEC) duly verified and certified by designated independent Third Party Inspection Agency.~~



~~In this regard, this is to certify that copies of documents pertaining to Technical Bid Evaluation Criteria (BEC) submitted to us by the bidder have been verified and certified by us with the originals and found to be genuine. We have signed and stamped on the copies of all the verified and certified documents.~~

~~(Signature of a person duly authorized to Sign on behalf of the TPIA)~~

~~(Seal of the Company)~~

~~Name: .....~~

~~Contact No.....~~

	<b>ELECTRICAL WORKS (SUPPLY &amp; ERECTION) FOR ALTERNATE POWER SUPPLY ARRANGEMENT OF VIKARMPUR GUEST HOUSE AT TALCHER FERTILIZERS LTD., ANGUL, ODISHA</b>	PC-183/E/ 8001 /S III	0	
		DOC. NO.	REV	
		Page 111 of 120		

F-20

**UNDERTAKING ON LETTERHEAD**

To,

M/s Talcher Fertilizers Limited

\_\_\_\_\_

SUB:

TENDER NO:

Dear Sir

We have read the clause regarding Provisions for Procurement from a Bidder which shares a land border with India, we certify that, bidder M/s \_\_\_\_\_ **(Name of Bidder)** is :

- (i) Not from such a country [    ]
- (ii) If from such a country, has been registered [    ]  
with the Competent Authority.

(Evidence of valid registration by the Competent Authority shall be attached)

***(Bidder is to tick appropriate option (✓ or X) above).***



We hereby certify that bidder M/s \_\_\_\_\_ **(Name of Bidder)** fulfills all requirements in this regard and is eligible to be considered against the tender.

Place: [Signature of Authorized Signatory of Bidder]

Date: Name:

Designation:

Seal:

	<b>ELECTRICAL WORKS (SUPPLY &amp; ERECTION) FOR ALTERNATE POWER SUPPLY ARRANGEMENT OF VIKARMPUR GUEST HOUSE AT TALCHER FERTILIZERS LTD., ANGUL, ODISHA</b>	PC-183/E/ 8001 /S III	0	
		DOC. NO.	REV	
		Page 112 of 120		

F-21

**CERTIFICATE FOR TENDERS FOR WORKS INVOLVING POSSIBILITY OF SUB-  
CONTRACTING**

To,

M/s Talcher Fertilizers Limited

\_\_\_\_\_

SUB:

TENDER NO:

Dear Sir



We have read the Provisions for Procurement from a Bidder which shares a land border with India as per Clause No. 54 of Section-III, we certify that bidder M/s .....(Name of Bidder) will not sub-contract any work to a contractor from such countries unless such contractor is registered with the Competent Authority.

Place: [Signature of Authorized Signatory of Bidder]

Date: Name:

Designation:

Seal:

	<b>ELECTRICAL WORKS (SUPPLY &amp; ERECTION) FOR ALTERNATE POWER SUPPLY ARRANGEMENT OF VIKARMPUR GUEST HOUSE AT TALCHER FERTILIZERS LTD., ANGUL, ODISHA</b>	PC-183/E/ 8001 /S III	0	
		DOC. NO.	REV	
		Page 113 of 120		

**NOT APPLICABLE FOR THIS TENDER**

**F-22**

**DECLARATION BY BIDDER TOWARDS MINIMUM LOCAL CONTENT  
(FOR SUPPLY OF GOODS / SERVICES / WORKS / EPC / LSTK )**

To,  
~~M/s Talcher Fertilizers Limited~~

**SUB:**

**TENDER NO:**

Dear Sir,

A. We M/s ..... (**Name of Bidder**) hereby confirm/certify that the goods / services offered vide our offer no..... dated ..... meets the following-

Sl. No.	Description	Confirmation
A	<del>Bidder meets the mandatory minimum Local content requirement of 20% for participating in the Bidding process under Public Procurement (Preference to Make in India) Policy. (In case bidder does not meet the minimum Local content requirement of 20%, such bidders are not allowed to participate in the Bidding process)</del>	<del>Confirmed.</del>
B	<del>The bidder meets mandatory minimum Local content requirement of 50% for claiming purchase preference under Public Procurement (Preference to Make in India) Policy</del>	<del>Confirmed / Not Confirmed</del>

B. The details of the location at which the local value addition is made as follows:

Sl. No.	Item Description	Details of the Location(s) where the local value addition is made
1.		
2.		

	<b>ELECTRICAL WORKS (SUPPLY &amp; ERECTION) FOR ALTERNATE POWER SUPPLY ARRANGEMENT OF VIKARMPUR GUEST HOUSE AT TALCHER FERTILIZERS LTD., ANGUL, ODISHA</b>	PC-183/E/ 8001 /S III	0	
		DOC. NO.	REV	
		Page 114 of 120		

Place: \_\_\_\_\_ [Signature of Authorized Signatory of Bidder]

Date: \_\_\_\_\_ Name: \_\_\_\_\_



\_\_\_\_\_ Designation: \_\_\_\_\_

\_\_\_\_\_ Seal: \_\_\_\_\_

**Note:**

- i. ~~The Authorized Signatory of Bidder shall be the person in whose name Power of Attorney has been issued.~~



	<b>ELECTRICAL WORKS (SUPPLY &amp; ERECTION) FOR ALTERNATE POWER SUPPLY ARRANGEMENT OF VIKARMPUR GUEST HOUSE AT TALCHER FERTILIZERS LTD., ANGUL, ODISHA</b>	PC-183/E/ 8001 /S III	0	
		DOC. NO.	REV	
		Page 115 of 120		

**F-23**

**CERTIFICATE FROM STATUTORY AUDITOR OR COST AUDITOR OF THE COMPANY (IN THE CASE OF COMPANIES) OR FROM A PRACTICING COST ACCOUNTANT OR PRACTICING CHARTERED ACCOUNTANT (IN RESPECT OF SUPPLIERS OTHER THAN COMPANIES) TOWARDS MINIMUM LOCAL CONTENT**

**(FOR SUPPLY OF GOODS/ SERVICES / WORKS / EPC / LSTK)**

To,  
M/s Talcher Fertilizers Limited

**SUB:**

**TENDER NO:**

Dear Sir

**A.** We..... the Statutory Auditor / Cost Auditor / Practicing Cost Accountant / Practicing Chartered Accountant) have verified relevant records of M/s ..... **(Name of the bidder)** and certify that M/s ..... **(Name of the bidder)** meet the mandatory minimum Local content requirement of .....% specified in tender document no.....for claiming purchase preference under Public Procurement (Preference to Make in India) Policy.

**B.** The **details of the location** at which the local value addition is made as follows:

Sl. No.	Item Description	Details of the Location(s) where the local value addition is made
1.		
2.		
3.		
4.		

Name of Audit Firm / Chartered Accountant:



**ELECTRICAL WORKS (SUPPLY & ERECTION)  
FOR  
ALTERNATE POWER SUPPLY ARRANGEMENT OF  
VIKARMPUR GUEST HOUSE  
AT TALCHER FERTILIZERS LTD., ANGUL, ODISHA**

PC-183/E/ 8001 /S III

0

DOC. NO.

REV

.



Page 116 of 120

[Signature of Authorized Signatory]

Date:

Name:

Designation:

Seal:

Membership No.:

	<b>ELECTRICAL WORKS (SUPPLY &amp; ERECTION) FOR ALTERNATE POWER SUPPLY ARRANGEMENT OF VIKARMPUR GUEST HOUSE AT TALCHER FERTILIZERS LTD., ANGUL, ODISHA</b>	PC-183/E/ 8001 /S III	0	
		DOC. NO.	REV	
		Page 117 of 120		

**F-24.**

**UNDERTAKING REGARDING SUBMISSION CONTRACT PERFORMANCE  
SECURITY(CPS) / SECURITY DEPOSIT (SD) WITHIN STIPULATED TIME LINE  
(to be submitted on letter head of bidder)**

To,

M/s Talcher Fertilizers Limited



SUB:  
TENDER NO:

**Dear Sir,**

We hereby confirm that we have clearly understood the requirement of Contract Performance Security (CPS) / Security Deposit (SD) specified in the tender document.

We also hereby confirm that in case of award of contract / order, we will submit Contract Performance Security (CPS) / Security Deposit (SD) within 30 days from the date of issuance of Fax of Acceptance.

Place:	[Signature of Authorized Signatory of Bidder]
Date:	Name:
	Designation:
	Bidder Name:
	Seal:

	<b>ELECTRICAL WORKS (SUPPLY &amp; ERECTION) FOR ALTERNATE POWER SUPPLY ARRANGEMENT OF VIKARMPUR GUEST HOUSE AT TALCHER FERTILIZERS LTD., ANGUL, ODISHA</b>	PC-183/E/ 8001 /S III	0	
		DOC. NO.	REV	
		Page 118 of 120		

**F-25**

**UNDERTAKING REGARDING SUBMISSION OF ELECTRONIC INVOICE (E-INVOICE AS  
PER GST LAWS)**

**(to be submitted on letter head along with documents for release of payment)**

To,  
M/s Talcher Fertilizers Limited

\_\_\_\_\_

SUB:  
DLOA NO:

**Dear Sir,**

We \_\_\_\_\_ (Name of the Supplier/Contractor/Service Provider/ Consultant) hereby confirm that E-Invoice provision as per the GST Law is



(i) Applicable to us [       ]

(ii) Not Applicable to us [       ]

**(Supplier/Contractor/Service Provider/ Consultant is to tick appropriate option (✓ or X) above).**

In case, same is applicable to us, we confirm that we will submit E-Invoice after complying with all the requirements of GST Laws. If the invoice issued without following this process, such invoice can-not be processed for payment by TFL as no ITC is allowed on such invoices. We also confirm that If input tax credit is not available to TFL for any reason attributable to Supplier/Contractor/Service Provider/ Consultant (both for E-invoicing cases and non-E-invoicing cases), then TFL shall not be obligated or liable to pay or reimburse GST (CGST & SGST/UTGST or IGST) claimed in the invoice(s) and shall be entitled to deduct / setoff / recover such GST amount (CGST & SGST/UTGST or IGST) or Input Tax Credit amount together with penalties and interest, if any, by adjusting against any amounts paid or becomes payable in future to the Supplier/Contractor/Service Provider/ Consultant under this contract or under any other contract.

Place: [Signature of Authorized Signatory of Bidder]  
Date: Name:  
Designation:  
Bidder Name:  
Seal:

	<b>ELECTRICAL WORKS (SUPPLY &amp; ERECTION) FOR ALTERNATE POWER SUPPLY ARRANGEMENT OF VIKARMPUR GUEST HOUSE AT TALCHER FERTILIZERS LTD., ANGUL, ODISHA</b>	PC-183/E/ 8001 /S III	0	
		DOC. NO.	REV	
		Page 119 of 120		

## Annexure-VII

By virtue of this Annexure-VII, all the corresponding clauses/provisions/guidelines in the existing tender document stand superseded by this Annexure.

1. **Authentication of documents pertaining to BEC, etc:** Bids shall be evaluated based on the self-certified documents submitted by Bidders. The authenticated documents will be submitted by bidder, on whom order/ contract is placed, after normalization of situation. An undertaking (as per modified proforma attached Appendix-1) to this effect shall be submitted by bidder in Bid.
2. **Submission of original Integrity Pact (IP) and Power of Attorney (POA):** Bidder(s) shall upload/submit scanned copy of Integrity Pact (IP) and Power of Attorney (POA) in their bids. The same shall be considered for evaluation of bid. The original Integrity Pact (IP) and Power of Attorney (POA) will be submitted by successful bidder(s) after normalization of situation.
3. **Affidavit / certified documents regarding Domestic Value Addition as per extant Policy to provide Preference to Domestically Manufactured Iron and Steel Products and other Preference Policies (i.e. PPP for MSEs, PP-LC, DMEP, etc.):**

Bidder will submit self-certified document as per prescribed proforma / provision of policy and undertaking (as per modified proforma attached Appendix-1) along with bid.

The Affidavit of Self Certification in original and / or the certification from statutory auditor / cost auditor/ practising cost accountant/ practising chartered accountant regarding Domestic Value Addition as per extant Policy to provide Preference to Domestically Manufactured Iron and Steel Products and other Preference Policies (i.e, PPP for MSEs, PP-LC, DMEP, etc.) in vogue will be submitted by bidder, on whom order/ contract is placed, after normalization of situation.

#### 4. **Security Deposit/Contract Performance Guarantee**

In case due date for submission of Security Deposit/Contract Performance Guarantee against the awarded order/ contract is within the restricted/ lockdown / curfew period, the same shall be extended upto 31<sup>st</sup>July 2021. During the aforesaid period, in case any payment is to be made against such order/ contract, the payment to supplier/ contractor/ consultant/ service provider may be released after deduction of Security deposit/ Initial Security Deposit from due payment after getting confirmation from supplier/ contractor/ consultant/ service provider.

All other terms and conditions of the tender document shall remain unchanged.

	<b>ELECTRICAL WORKS (SUPPLY &amp; ERECTION) FOR ALTERNATE POWER SUPPLY ARRANGEMENT OF VIKARMPUR GUEST HOUSE AT TALCHER FERTILIZERS LTD., ANGUL, ODISHA</b>	PC-183/E/ 8001 /S III	0	
		DOC. NO.	REV	
		Page 120 of 120		

**Appendix-1**

**UNDERTAKING REGARDING SUBMISSION OF AUTHENTICATED DOCUMENTS  
RELATING TO BEC, AFFIDAVIT / CERTIFIED DOCUMENTS FOR PURCHASE  
PREFERENCE POLICY (IES), ETC.**

To,

**M/s Talcher Fertilizers Limited,**

**Noida, Uttar Pradesh**

**SUB:**

**TENDER NO:**

**Dear Sir,**

We hereby confirm that due to COVID-19 situation, we are unable to submit the Authenticated documents relating to BEC and Affidavit / Certified Documents for Purchase Preference Policy(s), etc. (wherever applicable) as specified in tender document. Hence, we are submitting the self-certified documents relating to BEC and Affidavit / Certified Documents for Purchase Preference Policy(s), etc (wherever applicable).

We hereby confirm that in case of award of contract/order, we will submit Authenticated documents relating to BEC and Affidavit / Certified Documents for Purchase Preference Policy(s), etc. (wherever applicable) as per tender provisions after normalization of situation.

Place: [Signature of Authorized Signatory of Bidder]

Date: Name:

Designation:

Name of Bidder:

Seal:



PROJECTS & DEVELOPMENT INDIA LIMITED

PC-183 / E / 8001 /S-IV

0

DOC. NO.

REV.



Page 1 of 67

## GENERAL CONDITIONS OF CONTRACT



**ELECTRICAL WORKS (SUPPLY & ERECTION)  
FOR ALTERNATE POWER SUPPLY  
ARRANGEMENT OF VIKARMPUR GUEST HOUSE  
AT TALCHER FERTILIZERS LTD., ANGUL, ODISHA  
GENERAL CONDITIONS OF CONTRACT**

PC-183 /E/8001/S-IV

0

DOC. NO.

REV.

Page 2 of 67



## TABLE OF CONTENTS

<b>Sl.No.</b>	<b>Description</b>
(i)	<b>TABLE OF CONTENTS</b>
(II)	<b>SUBMISSION OF TENDER</b>
<b>SECTION-I (DEFINITIONS)</b>	
1.0	Definition of Terms
<b>SECTION-II (GENERAL INFORMATIONS)</b>	
2.0	General Information
2.1	(a) Location of Site (b) Access by Road
2.2	Scope of Work
2.3	Water Supply
2.4	Power Supply
2.5	Land for Contractor's field office, Godown and Workshop
2.6	Land for Residential Accommodation
<b>SECTION-III (GENERAL INSTRUCTIONS TO TENDERERS)</b>	
3.0	Submission of Tender
4.0	Documents
4.1	General
4.2	All pages to be initialed
4.3	Rates to be in figures and words
4.4	Corrections and Erasures
4.5	Signature of Tenderer
4.6	Witness
4.7	Details of Experience
4.8	Liability of Government of India
5.0	Transfer of Tender Documents
6.0	Earnest Money
7.0	Validity
8.0	Addenda/Corrigenda
9.0	Right of Employer to Accept or Reject Tender
10.0	Time Schedule
11.0	Tenderer's Responsibility
12.0	Retired Government or Company Officers
13.0	Signing of the Contract
14.0	Field Management & Controlling/Coordinating Authority
15.0	Note to Schedule of Rates
16.0	16.1 Policy for Tenders under consideration 16.2 Zero Deviation
17.0	Award of Contract





**ELECTRICAL WORKS (SUPPLY & ERECTION)  
FOR ALTERNATE POWER SUPPLY  
ARRANGEMENT OF VIKARMPUR GUEST HOUSE  
AT TALCHER FERTILIZERS LTD., ANGUL, ODISHA  
GENERAL CONDITIONS OF CONTRACT**

PC-183 /E/8001/S-IV

0

DOC. NO.

REV.

Page 3 of 67



- 18.0 Clarification of Tender Document  
19.0 Local Conditions  
20.0 Abnormal Rates

**SECTION-IV (GENERAL OBLIGATIONS)**

- 21.1 Priority of Contract Documents
- 21.2 Headings & Marginal Notes
- 21.3 Singular and Plural
- 21.4 Interpretation
- 22.0 Special Conditions of Contract
- 23.0 Contractor to obtain his own information
- 24.0 Contract Performance Security
- 25.0 Time of Performance
- 25.1 Time for Mobilization
- 25.2 Time Schedule of Construction
- 26.0 Force Majeure
- 26.1 Conditions for Force Majeure
- 26.2 Outbreak of War
- 27.0 Price Reduction Schedule
- 27.3 Bonus for Early Completion
- 28.0 Rights of Employer to forfeit Contract Performance Security
- 29.0 Failure by the Contractor to comply with the provisions of the contract
- 30.0 Contractor remains liable to pay compensation if action not taken under Clause 29.0
- 31.0 Change in Constitution
- 32.0 -A Termination of Contract for Death
- 32.0-B Termination of Contract for Liquidation, Bankruptcy etc.
- 32.0-C Termination of Contract for Non-Performance and subsequently putting the Contractor on Holiday
- 33.0 Members of the Employer not individually liable
- 34.0 Employer not bound by personal representations
- 35.0 Contractor's office at site
- 36.0 Contractor's subordinate staff and their conduct
- 37.0 Sub letting of Works
- i) Sub contracts for Temporary works etc.
- ii) List of sub-contractors to be supplied
- iii) Contractor's liability not limited by Sub-Contractors
- iv) Employer may terminate sub contracts
- v) No remedy for action taken under this clause
- 38.0 Power of Entry
- 39.0 Contractor's responsibility with Mechanical, Electrical, Intercommunication System, Air Conditioning Contractors and other agencies
- 40.0 Other Agencies at site
- 41.0 Notices
- 41.1 To the Contractor



**ELECTRICAL WORKS (SUPPLY & ERECTION)  
FOR ALTERNATE POWER SUPPLY  
ARRANGEMENT OF VIKARMPUR GUEST HOUSE  
AT TALCHER FERTILIZERS LTD., ANGUL, ODISHA  
GENERAL CONDITIONS OF CONTRACT**

PC-183 /E/8001/S-IV

0

DOC. NO.

REV.

Page 4 of 67



41.2	To the Employer
42.0	Rights of various Interests
43.0	Patents and Royalties
44.0	Liens
45.0	Delays by Employer or his authorized agents
46.0	Payments if Contract is terminated
47.0	No waiver of Rights
48.0	Certificate not to affect Right of Employer and Liability of Contractor
49.0	Languages & Measures
50.0	Transfer of Title
51.0	Release of Information
52.0	Brand Names
53.0	Completion of Contract
54.0	Spares

**SECTION-V (PERFORMANCE OF WORK)**

55.0	Execution of Work
56.0	Co-ordination and Inspection of work
57.0	Work in Monsoon & Dewatering
58.0	Work on Sundays & Holidays
59.0	General Conditions for construction & Erection Work
60.0	Alterations in specification, Design & Extra Work
61.0	Drawings to be supplied by the Employer
62.0	Drawings to be supplied by the Contractor
63.0	Setting out works
64.0	Responsibility for Levels and Alignment
65.0	Materials to be supplied by contractor
66.0	Stores supplied by Employer
67.0	Conditions for issue of material
68.0	Materials Procured with assistance of Employer/Return of surplus
69.0	Materials obtained from dismantling
70.0	Articles of Value found
71.0	Discrepancies between instructions
72.0	Action where no specification is issued
73.0	Inspection of Works
74.0	Tests for Quality of Works
75.0	Samples for approval
76.0	Action and Compensation in case of bad work
77.0	Suspension of Work
78.0	Employer may do part of work
79.0	Possession prior to completion
80.0	Twelve months period of liability from the date of issue of completion certificate
80.3	Limitation of Liability
81.0	Care of Works
81.1	Defects prior to taking over
81.2	Defects after taking over
82.0	Guarantee/Transfer of Guarantee



**ELECTRICAL WORKS (SUPPLY & ERECTION)  
FOR ALTERNATE POWER SUPPLY  
ARRANGEMENT OF VIKARMPUR GUEST HOUSE  
AT TALCHER FERTILIZERS LTD., ANGUL, ODISHA  
GENERAL CONDITIONS OF CONTRACT**

PC-183 /E/8001/S-IV

0

DOC. NO.

REV.

Page 5 of 67



- 83.0 Training of Employer's personnel  
84.0 Replacement of Defective parts & materials  
85.0 Indemnity  
86.0 Construction Aids, Equipments, Tools & Tackles

**SECTION-VI (CERTIFICATES AND PAYMENTS)**

- 87.0 Schedule of Rates and Payments  
i) Contractor's Remuneration  
ii) Schedule of Rates to be inclusive  
iii) Schedule of Rates to cover construction equipment, materials, labour etc.  
iv) Schedule of Rates to cover Royalties, Rents and claims.  
v) Schedule of Rates to cover taxes & duties  
vi) Schedule of Rates to cover risks of delay  
vii) Schedule of Rates cannot be altered  
88.0 Procedure for Measurement and billing of works in progress  
88.1 Billing Procedure  
88.2 Secured Advance on materials  
88.3 Dispute in mode of measurement  
88.4 Rounding of Amounts  
89.0 Lumpsum in Tender  
90.0 Running Account Payments to be regarded as advances  
91.0 Notices of Claims for Additional Payments  
92.0 Payment of Contractor's bills  
93.0 Receipt for Payment  
94.0 Completion Certificate  
94.1 Application for Completion Certificate  
94.2 Completion Certificate  
94.3 Completion Certificate Documents  
95.0 Final Decision & Final Certificate  
96.0 Certificate and Payments No evidence of completion  
97.0 Deduction from Contract Price

**SECTION-VII (TAXES AND INSURANCE)**

- 98.0 Taxes, Duties, Octroi etc.  
99.0 Sales Tax/Turnover Tax  
100.0 Statutory Variations  
101.0 Insurance  
101.1 General  
i) Employees State Insurance Act  
ii) Workmen Compensation and Employee's Liability Insurance  
iii) Accident or injury to workmen  
iv) Transit Insurance  
v) Automobile  
vi) General Liability  
vii) Any other Insurance required under law or regulations by

Employer



**ELECTRICAL WORKS (SUPPLY & ERECTION)  
FOR ALTERNATE POWER SUPPLY  
ARRANGEMENT OF VIKARMPUR GUEST HOUSE  
AT TALCHER FERTILIZERS LTD., ANGUL, ODISHA  
GENERAL CONDITIONS OF CONTRACT**

PC-183 /E/8001/S-IV

0

DOC. NO.

REV.

Page 6 of 67



102.0 Damage to Property or to any Person or any Third Party

**SECTION-VIII (LABOUR LAWS)**

103.0 Labour laws  
104.0 Implementation of Apprentices Act 1961  
105.0 Contractor to indemnify the Employer  
106.0 Health and Sanitary Arrangement for worker

**SECTION-IX (APPLICABLE LAWS AND SETTLEMENT OF DISPUTES)**

107.0 Arbitration  
108.0 Jurisdiction

**SECTION-X (SAFETY CODES)**

109.0 General  
110.0 Safety Regulations  
111.0 First Aid and Industrial Injuries  
112.0 General Rules  
113.0 Contractor's barricades  
114.0 Scaffolding  
115.0 Excavation and Trenching  
116.0 Demolition/General Safety  
117.0 Care in Handling Inflammable Gas  
118.0 Temporary Combustible Structures  
119.0 Precautions Against Fire  
120.0 Explosives  
121.0 Mines Act  
122.0 Preservation of Places  
123.0 Outbreak of Infectious diseases  
124.0 Use of intoxicants



**ELECTRICAL WORKS (SUPPLY & ERECTION)  
FOR ALTERNATE POWER SUPPLY  
ARRANGEMENT OF VIKARMPUR GUEST HOUSE  
AT TALCHER FERTILIZERS LTD., ANGUL, ODISHA  
GENERAL CONDITIONS OF CONTRACT**

PC-183 /E/8001/S-IV

0

DOC. NO.

REV.

Page 7 of 67



## General Conditions of Contract

### Section- I. Definitions

#### 1. Definition of Terms:

- 1.1 In this CONTRACT (as here-in-after defined) the following words and expressions shall have the meanings hereby assigned to them except where the context otherwise required.
- 1.1.1 The OWNER/EMPLOYER/COMPANY/TFL means Talcher Fertilizers Ltd. (a joint venture of four major Public Sector Units – M/s GAIL (India) Limited, M/s Rastriya Chemicals & Fertilizers Ltd., M/s Coal India Ltd. and M/s Fertilizers Corporation of India Ltd.) and having its Registered office at Plot 2/H, Kalpana Area, BJB Nagar, Khurda, Bhubaneswar-751 014 and includes its successors and assigns.
- 1.1.2 The "CONTRACTOR" means the person or the persons, firm or Company or corporation whose tender has been accepted by the EMPLOYER and includes the CONTRACTOR's legal Representatives his successors and permitted assigns.
- 1.1.3 The "ENGINEER/ENGINEER-IN-CHARGE" shall mean the person designated from time to time by the TFL and shall include those who are expressly authorized by him to act for and on his behalf for operation of this CONTRACT.
- 1.1.4 The "WORK" shall mean and include all items and things to be supplied/ done and services and activities to be performed by the CONTRACTOR in pursuant to and in accordance with CONTRACT or part thereof as the case may be and shall include all extra, additional, altered or substituted works as required for purpose of the CONTRACT.
- 1.1.5 The "PERMANENT WORK" means and includes works which will be incorporated in and form a part of the work to be handed over to the EMPLOYER by the CONTRACTOR on completion of the CONTRACT.
- 1.1.6 "CONSTRUCTION EQUIPMENT" means all appliances/equipment and things whatsoever nature for the use in or for the execution, completion, operation, or maintenance of the work or temporary works (as hereinafter defined) but does not include materials or other things intended to form or to be incorporated into the WORK, or camping facilities.
- 1.1.7 "CONTRACT DOCUMENTS" means collectively the Tender Documents, Designs, Drawings, Specification, Schedule of Quantities and Rates, Letter of Acceptance and agreed variations if any, and such other documents constituting the tender and acceptance thereof.
- 1.1.8 CONSULTANT: means Projects & Development India Ltd. (PDIL) who are the consulting engineer to the Employer for this project and having registered office at PDIL Bhawan, A-14, Sector 1, Noida - 201301 (U.P.)
- 1.1.9 The "SUB-CONTRACTOR" means any person or firm or Company (other than the CONTRACTOR) to whom any part of the work has been entrusted by the CONTRACTOR, with the written consent of the ENGINEER-IN-CHARGE, and the legal representatives, successors and permitted assigns of such person, firm or company.



**ELECTRICAL WORKS (SUPPLY & ERECTION)  
FOR ALTERNATE POWER SUPPLY  
ARRANGEMENT OF VIKARMPUR GUEST HOUSE  
AT TALCHER FERTILIZERS LTD., ANGUL, ODISHA  
GENERAL CONDITIONS OF CONTRACT**

PC-183 /E/8001/S-IV

0

DOC. NO.

REV.

Page 8 of 67



- 1.1.10 The "CONTRACT" shall mean the Agreement between the EMPLOYER and the CONTRACTOR for the execution of the works including therein all contract documents.
- 1.1.11 The "SPECIFICATION" shall mean all directions the various technical specifications, provisions attached and referred to the Tender Documents which pertain to the method and manner of performing the work or works to the quantities and qualities of the work or works and the materials to be furnished under the CONTRACT for the work or works, as may be amplified or modified by the TFL or ENGINEER-IN-CHARGE during the performance of CONTRACT in order to provide the unforeseen conditions or in the best interests of the work or works. It shall also include the latest edition of relevant Standard Specifications including all addenda/corrigenda published before entering into CONTRACT.
- 1.1.12 The "DRAWINGS" shall include maps, plans and tracings or prints or sketches thereof with any modifications approved in writing by the ENGINEER-IN-CHARGE and such other drawing as may, from time to time, be furnished or approved in writing by the ENGINEER-IN-CHARGE.
- 1.1.13 The "TENDER" means the proposal along with supporting documents submitted by the CONTRACTOR for consideration by the EMPLOYER.
- 1.1.14 The "CHANGE ORDER" means an order given in writing by the ENGINEER-IN-CHARGE to effect additions to or deletion from and alteration in the works.
- 1.1.15 The "COMPLETION CERTIFICATE" shall mean the certificate to be issued by the ENGINEER-IN-CHARGE when the works have been completed entirely in accordance with CONTRACT DOCUMENT to his satisfaction.
- 1.1.16 The "FINAL CERTIFICATE" in relation to a work means the certificate regarding the satisfactory compliance of various provision of the CONTRACT by the CONTRACTOR issued by the ENGINEER-IN- CHARGE/EMPLOYER after the period of liability is over.
- 1.1.17 "DEFECT LIABILITY PERIOD" in relation to a work means the specified period from the date of COMPLETION CERTIFICATE upto the date of issue of FINAL CERTIFICATE during which the CONTRACTOR stands responsible for rectifying all defects that may appear in the works executed by the CONTRACTOR in pursuance of the CONTRACT and includes warranties against Manufacturing/Fabrication/ Erection/Construction defects covering all materials plants, equipment, components, and the like supplied by the CONTRACTOR, works executed against workmanship defects.
- 1.1.18 The "APPOINTING AUTHORITY" for the purpose of arbitration shall be the CHAIRMAN and MANAGING DIRECTOR or any other person so designated by the EMPLOYER.
- 1.1.19 "TEMPORARY WORKS" shall mean all temporary works of every kind required in or about the execution, completion or maintenance of works.
- 1.1.20 "PLANS" shall mean all maps, sketches and layouts as are incorporated in the CONTRACT in order to define broadly the scope and specifications of the work or works, and all reproductions thereof.
- 1.1.21 "SITE" shall mean the lands and other places on, under, in or through which the permanent works are to be carried out and any other lands or places provided by



**ELECTRICAL WORKS (SUPPLY & ERECTION)  
FOR ALTERNATE POWER SUPPLY  
ARRANGEMENT OF VIKARMPUR GUEST HOUSE  
AT TALCHER FERTILIZERS LTD., ANGUL, ODISHA  
GENERAL CONDITIONS OF CONTRACT**

PC-183 /E/8001/S-IV

0

DOC. NO.

REV.

Page 9 of 67



the EMPLOYER for the purpose of the CONTRACT.

- 1.1.22 "NOTICE IN WRITING OR WRITTEN NOTICE" shall mean a notice in written, typed or printed characters sent (unless delivered personally or otherwise proved to have been received by the addressee) by registered post to the latest known private or business address or registered office of the addressee and shall be deemed to have been received in the ordinary course of post it would have been delivered.
- 1.1.23 "APPROVED" shall mean approved in writing including subsequent written confirmation of previous verbal approval and "APPROVAL" means approval in writing including as aforesaid.
- 1.1.24 "LETTER OF INTENT/FAX OF INTENT" shall mean intimation by a Fax/Letter to Tenderer(s) that the tender has been accepted in accordance with the provisions contained in the letter.
- 1.1.25 "DAY" means a day of 24 hours from midnight to midnight irrespective of the number of hours worked in that day.
- 1.1.26 "WORKING DAY" means any day which is not declared to be holiday or rest day by the EMPLOYER.
- 1.1.27 "WEEK" means a period of any consecutive seven days.
- 1.1.28 "METRIC SYSTEM" - All technical documents regarding the construction of works are given in the metric system and all work in the project should be carried out according to the metric system. All documents concerning the work shall also be maintained in the metric system.
- 1.1.29 "VALUE OF CONTRACT" or "TOTAL CONTRACT PRICE" shall mean the sum accepted or the sum calculated in accordance with the prices accepted in tender and/or the CONTRACT rates as payable to the CONTRACTOR for the entire execution and full completion of the work, including change order.
- 1.1.30 "LANGUAGE FOR DRAWINGS AND INSTRUCTION" All the drawings, titles, notes, instruction, dimensions, etc. shall be in English Language.
- 1.1.31 "MOBILIZATION" shall mean establishment of sufficiently adequate infrastructure by the CONTRACTOR at "SITE" comprising of construction equipments, aids, tools tackles including setting of site offices with facilities such as power, water, communication etc. establishing manpower organization comprising of Resident Engineers, Supervising personnel and an adequate strength of skilled, semi-skilled and un-skilled workers, who with the so established infrastructure shall be in a position to commence execution of work at site(s), in accordance with the agreed Time Schedule of Completion of Work. "MOBILISATION" shall be considered to have been achieved, if the CONTRACTOR is able to establish infrastructure as per Time Schedule, where so warranted in accordance with agreed schedule of work implementation to the satisfaction of ENGINEER-IN-CHARGE/ EMPLOYER.
- 1.1.32 "COMMISSIONING" shall mean pressing into service of the system including the plant(s), equipment(s), vessel(s), pipeline, machinery(ies), or any other section or sub-section of installation(s) pertaining to the work of the CONTRACTOR after successful testing and trial runs of the same.
- "COMMISSIONING" can be either for a completed system or a part of system of a combination of systems or sub-systems and can be performed in any sequence as desired by EMPLOYER and in a manner established to be made





**ELECTRICAL WORKS (SUPPLY & ERECTION)  
FOR ALTERNATE POWER SUPPLY  
ARRANGEMENT OF VIKARMPUR GUEST HOUSE  
AT TALCHER FERTILIZERS LTD., ANGUL, ODISHA  
GENERAL CONDITIONS OF CONTRACT**

PC-183 /E/8001/S-IV

0

DOC. NO.

REV.

Page 10 of 67



suited according to availability of pre-requisites. Any such readjustments made by EMPLOYER in performance of "COMMISSIONING" activity will not be construed to be violating CONTRACT provisions and CONTRACTOR shall be deemed to have provided for the same.

**Section-II General Information**

**2. General Information**

2.1 a) Location of Site: The proposed location of Project site is defined in the Special Conditions of Contract.

b) Access by Road: CONTRACTOR, if necessary, shall build other temporary access roads to the actual site of construction for his own work at his own cost. The CONTRACTOR shall be required to permit the use of the roads so constructed by him for vehicles of any other parties who may be engaged on the project site. The CONTRACTOR shall also facilitate the construction of the permanent roads should the construction there of start while he is engaged on this work. He shall make allowance in his tender for any inconvenience he anticipates on such account.

Non-availability of access roads, railway siding and railway wagons for the use of the CONTRACTOR shall in no case condone any delay in the execution of WORK nor be the cause for any claim for compensation against the EMPLOYER.

2.2 Scope of Work: The scope of WORK is defined in the Technical Part of the tender document. The CONTRACTOR shall provide all necessary materials, equipment, labour etc. for the execution and maintenance of the WORK till completion unless otherwise mentioned in the Tender Document.

2.3 Water Supply: Contractor will have to make his own arrangements for supply of water to his labour camps and for works. All pumping installations, pipe net work and distribution system will have to be carried out by the Contractor at his own risk and cost.

Alternatively the Employer at his discretion may endeavour to provide water to the Contractor at the Employer's source of supply provided the Contractor makes his own arrangement for the water meter which shall be in custody of the Employer and other pipe net works from source of supply and such distribution pipe network shall have prior approval of the Engineer-in-Charge so as not to interfere with the layout and progress of the other construction works. In such case, the rate for water shall be deducted from the running account bills.

However, the Employer does not guarantee the supply of water and this does not relieve the Contractor of his responsibility in making his own arrangement and for the timely completion of the various works as stipulated.

2.4 Power Supply:

2.4.1 Subject to availability, EMPLOYER will supply power at 400/440 V at only one point at the nearest sub-station, from where the CONTRACTOR will make his own arrangement for temporary distribution. The point of supply will not be more than 500 m away from the CONTRACTOR'S premises. All the works will be done as per the applicable regulations and passed by the ENGINEER-IN-CHARGE. The temporary line will be removed forthwith after the completion of work or if there is any hindrance caused to the other works due



**ELECTRICAL WORKS (SUPPLY & ERECTION)  
FOR ALTERNATE POWER SUPPLY  
ARRANGEMENT OF VIKARMPUR GUEST HOUSE  
AT TALCHER FERTILIZERS LTD., ANGUL, ODISHA  
GENERAL CONDITIONS OF CONTRACT**

PC-183 /E/8001/S-IV

0

DOC. NO.

REV.

Page 11 of 67



to the alignment of these lines, the CONTRACTOR will re-route or remove the temporary lines at his own cost. The CONTRACTOR at his cost will also provide suitable electric meters, fuses, switches, etc. for purposes of payment to the EMPLOYER which should be in the custody and control of the EMPLOYER. The cost of power supply shall be payable to the EMPLOYER every month for Construction Works power which would be deducted from the running account bills. The EMPLOYER shall not, however, guarantee the supply of electricity nor have any liability in respect thereof. No claim for compensation for any failure or short supply of electricity will be admissible.

- 2.4.2 It shall be the responsibility of the CONTRACTOR to provide and maintain the complete installation on the load side of the supply with due regard to safety requirement at site. All cabling, equipment, installations etc. shall comply in all respects with the latest statutory requirements and safety provisions i.e., as per the Central/State Electricity Acts and Rules etc. The CONTRACTOR will ensure that his equipment and Electrical Wiring etc., are installed, modified, maintained by a licensed Electrician/Supervisor. A test certificate is to be produced to the ENGINEER-IN-CHARGE for his approval, before power is made available.
- 2.4.3 At all times, IEA regulations shall be followed failing which the EMPLOYER has a right to disconnect the power supply without any reference to the CONTRACTOR. No claim shall be entertained for such disconnection by the ENGINEER-IN-CHARGE. Power supply will be reconnected only after production of fresh certificate from authorized electrical supervisors.
- 2.4.4 The EMPLOYER is not liable for any loss or damage to the CONTRACTOR's equipment as a result of variation in voltage or frequency or interruption in power supply or other loss to the CONTRACTOR arising therefrom.
- 2.4.5 The CONTRACTOR shall ensure that the Electrical equipment installed by him are such that average power factors does not fall below 0.90 at his premises. In case power factor falls below 0.90 in any month, he will reimburse to the EMPLOYER at the penal rate determined by the EMPLOYER for all units consumed during the month.
- 2.4.6 The power supply required for CONTRACTOR's colony near the plant site will be determined by the EMPLOYER and shall be as per State Electricity Board's Rules and other statutory provisions applicable for such installations from time to time. In case of power supply to CONTRACTOR's colony, the power will be made available at a single point and the CONTRACTOR shall make his own arrangement at his own cost for distribution to the occupants of the colony as per Electricity Rules and Acts. The site and colony shall be sufficiently illuminated to avoid accidents.
- 2.4.7 The CONTRACTOR will have to provide and install his own lights and power meters which will be governed as per Central/State Government Electricity Rules. The meters shall be sealed by the EMPLOYER.
- 2.4.8 In case of damage of any of the EMPLOYER's equipment on account of fault, intentional or unintentional on the part of the CONTRACTOR, the EMPLOYER reserves the right to recover the cost of such damage from the CONTRACTOR's bill. Cost of HRC Fuses replaced at the EMPLOYER's terminals due to any fault in the CONTRACTOR's installation shall be to CONTRACTOR's account at the rates decided by the ENGINEER-IN-CHARGE.
- 2.4.9 Only motors upto 3 HP will be allowed to be started direct on line. For motors above 3 HP and upto 100 HP a suitable Starting device approved by the ENGINEER- IN-CHARGE shall be provided by the CONTRACTOR. For motors



**ELECTRICAL WORKS (SUPPLY & ERECTION)  
FOR ALTERNATE POWER SUPPLY  
ARRANGEMENT OF VIKARMPUR GUEST HOUSE  
AT TALCHER FERTILIZERS LTD., ANGUL, ODISHA  
GENERAL CONDITIONS OF CONTRACT**

PC-183 /E/8001/S-IV

0

DOC. NO.

REV.

Page 12 of 67



above 100 HP slipring induction motors with suitable starting devices as approved by the ENGINEER- IN-CHARGE shall be provided by the CONTRACTOR.

- 2.4.10 The CONTRACTOR shall ensure at his cost that all electrical lines and equipment and all installations are approved by the State Electricity Inspector before power can be supplied to the EMPLOYER.
- 2.4.11 The total requirement of power shall be indicated by the tenderer alongwith his tender.
- 2.5 Land for Contractor's Field Office, Godown and Workshop: The EMPLOYER will, at his own discretion and convenience and for the duration of the execution of the work make available near the site, land for construction of CONTRACTOR's Temporary Field Office, godowns workshops and assembly yard required for the execution of the CONTRACT. The CONTRACTOR shall at his own cost construct all these temporary buildings and provide suitable water supply and sanitary arrangement and get the same approved by the ENGINEER-IN-CHARGE.

On completion of the works undertaken by the CONTRACTOR, he shall remove all temporary works erected by him and have the SITE cleaned as directed by ENGINEER-IN-CHARGE. If the CONTRACTOR shall fail to comply with these requirements, the ENGINEER-IN-CHARGE may at he expenses of the CONTRACTOR remove such surplus, and rubbish materials and dispose off the same as he deems fit and get the site cleared as aforesaid; and CONTRACTOR shall forthwith pay the amount of all expenses so incurred and shall have no claim in respect of any such surplus materials disposed off as aforesaid. But the EMPLOYER reserves the right to ask the CONTRACTOR any time during the pendency of the CONTRACT to vacate the land by giving 7 days notice on security reasons or on national interest or otherwise. Rent may be charged for the land so occupied from contractor by the Employer.

The CONTRACTOR shall put up temporary structures as required by them for their office, fabrication shop and construction stores only in the area allocated to them on the project site by the EMPLOYER or his authorized representative. No tea stalls/canteens should be put up or allowed to be put up by any CONTRACTOR in the allotted land or complex area without written permission of the EMPLOYER.

No unauthorized buildings, constructions or structures should be put up by the CONTRACTOR anywhere on the project site.

For uninterrupted fabrication work, the CONTRACTOR shall put up temporary covered structures at his cost within Area in the location allocated to them in the project site by the EMPLOYER or his authorized representative.

No person except for authorized watchman shall be allowed to stay in the plant area/CONTRACTOR's area after completion of the day's job without prior written permission from ENGINEER-IN-CHARGE.

- 2.6 Land for Residential Accommodation:- No Land shall be made available for residential accommodation for staff and labour of CONTRACTOR.

**Section-III. General Instructions to Tenderers**

**3. Submission of Tender:**

- 3.1 TENDER must be submitted without making any additions, alterations, and as per details given in other clauses hereunder. The requisite details shall be filled in by the TENDERER at space provided under "Submission of Tender" at the beginning of GCC of Tender Document. The rate shall be filled only in the schedule given in this Tender Document.



**ELECTRICAL WORKS (SUPPLY & ERECTION)  
FOR ALTERNATE POWER SUPPLY  
ARRANGEMENT OF VIKARMPUR GUEST HOUSE  
AT TALCHER FERTILIZERS LTD., ANGUL, ODISHA  
GENERAL CONDITIONS OF CONTRACT**

PC-183 /E/8001/S-IV

0

DOC. NO.

REV.

Page 13 of 67



3.2 Addenda/ Corrigenda to this Tender Document, if issued, must be signed, submitted along with the Tender Document. the tenderer should write clearly the revised quantities in Schedule of Rates of Tender Document and should price the WORK based on revised quantities when amendments of quantities are issued in addenda.

3.3 Covering letter along with its enclosures accompanying the Tender Document and all further correspondence shall be submitted in duplicate.

3.4 Tenderers are advised to submit quotations based strictly on the terms and conditions and specifications contained in the Tender Documents and not to stipulate any deviations.

~~3.5 Tenders should always be placed in double sealed covers, super scribing ["QUOTATION DO NOT OPEN" Tender for \_\_\_\_\_ Project of Talcher Fertilizers Ltd. due for opening on \_\_\_\_\_]. The Full Name, Address and Telegraphic Address, Fax No. of the Tenderers shall be written on the bottom left hand corner of the sealed cover.~~

**4. Documents:**

**4.1 General:**

The tenders as submitted, will consist of the following:

- i) Complete set of Tender Documents (Original) as sold duly filled in and signed by the tenderer as prescribed in different clauses of the Tender Documents.
- ii) Earnest money in the manner specified in Clause 6 hereof.
- iii) Power of Attorney or a true copy thereof duly attested by a Gazetted Officer in case an authorized representative has signed the tender, as required by Clause 14 hereof.
- iv) Information regarding tenderers in the proforma enclosed.
- v) Details of work of similar type and magnitude carried out by the Tenderer in the proforma provided in the tender document.
- vi) Organization chart giving details of field management at site, the tenderer proposes to have for this job.
- vii) Details of construction plant and equipments available with the tenderer for using in this work.
- viii) Solvency Certificate from Scheduled Bank to prove the financial ability to carry out the work tendered for.
- ix) Latest Balance Sheet and Profit & Loss Account duly audited.
- x) Details of present commitment as per proforma enclosed to tender.
- xi) Data required regarding SUB-CONTRACTOR(s)/ Supplier/ Manufacturers and other technical information the tenderer wish to furnish.
- xii) Provident fund registration certificate
- xiii) List showing all enclosures to tender.

4.2 All pages are to be Initiated: All signatures in Tender Documents shall be dated, as well



**ELECTRICAL WORKS (SUPPLY & ERECTION)  
FOR ALTERNATE POWER SUPPLY  
ARRANGEMENT OF VIKARMPUR GUEST HOUSE  
AT TALCHER FERTILIZERS LTD., ANGUL, ODISHA  
GENERAL CONDITIONS OF CONTRACT**

PC-183 /E/8001/S-IV

0

DOC. NO.

REV.

Page 14 of 67



as, all the pages of all sections of Tender Documents shall be initialed at the lower right hand corner and signed wherever required in the tender papers by the TENDERER or by a person holding power of attorney authorizing him to sign on behalf of the tenderer before submission of tender.

- 4.3 Rates to be in Figures and Words: The tender should quote in English both in figures as well as in words the rates and amounts tendered by him in the Schedule of Rates of Tender submitted by the CONTRACTOR for each item and in such a way that interpolation is not possible. The amount for each item should be worked out and entered and requisite total given of all items, both in figures and in words. The tendered amount for the work shall be entered in the tender and duly signed by the Tenderer.

If some discrepancies are found between the RATES in FIGURES and WORDS or the AMOUNT shown in the tender, the following procedure shall be followed:

- When there is difference between the rates in figures and words, the rate which corresponds to the amount worked out by the tenderer shall be taken as correct.
- When the rate quoted by the tenderer in figures and words tally but the amount is incorrect the rate quoted by the tenderer shall be taken as correct.
- When it is not possible to ascertain the correct rate by either of above methods, the rate quoted in words shall be taken as correct.

- 4.4 Corrections and Erasures: All correction(s) and alteration(s) in the entries of tender paper shall be signed in full by the TENDERER with date. No erasure or over writing is permissible.

4.5 Signature of Tenderer:

- 4.5.1 The TENDERER shall contain the name, residence and place of business of person or persons making the tender and shall be signed by the TENDERER with his usual signature. Partnership firms shall furnish the full names of all partners in the tender. It should be signed in the partnership's name by all the partners or by duly authorized representatives followed by the name and designation of the person signing. Tender by a corporation shall be signed by an authorized representative, and a Power of Attorney in that behalf shall accompany the tender. A copy of the constitution of the firm with names of all partners shall be furnished.

- 4.5.2 When a tenderer signs a tender in a language other than English, the total amount tendered should, in addition, be written in the same language. The signature should be attested by at least one witness.

- 4.6 Witness: Witness and sureties shall be persons of status and property and their names, occupation and address shall be stated below their signature.

- 4.7 Details of Experience: The tenderer should furnish, along with his tender, details of previous experience in having successfully completed in the recent past works of this nature, together with the names of Employers, location of sites and value of contract, date of commencement and completion of work, delays if any, reasons of delay and other details along with documentary evidence(s).

- 4.8 Liability of Government of India: It is expressly understood and agreed by and between Bidder or/Contractor and M/s Talcher Fertilizers Ltd., and that M/s Talcher Fertilizers Ltd., is entering into this agreement solely on its own behalf and not on behalf of any other person or entity. In particular, it is expressly understood and agreed that the Government of India is not a party to this agreement and has no liabilities, obligations or rights hereunder. It is expressly understood and agreed that M/s Talcher Fertilizers Ltd. is an independent legal entity with power and authority



**ELECTRICAL WORKS (SUPPLY & ERECTION)  
FOR ALTERNATE POWER SUPPLY  
ARRANGEMENT OF VIKARMPUR GUEST HOUSE  
AT TALCHER FERTILIZERS LTD., ANGUL, ODISHA  
GENERAL CONDITIONS OF CONTRACT**

PC-183 /E/8001/S-IV

0

DOC. NO.

REV.

Page 15 of 67



to enter into contracts solely on its own behalf under the applicable Laws of India and general principles of Contract Law. The Bidder/Contractor expressly agrees, acknowledges and understands that M/s Talcher Fertilizers Ltd. is not an agent, representative or delegate of the Government of India. It is further understood and agreed that the Government of India is not and shall not be liable for any acts, omissions, commissions, breaches or other wrongs arising out of the contract. Accordingly, Bidder/Contractor hereby expressly waives, releases and foregoes any and all actions or claims, including cross claims, impleader claims or counter claims against the Government of India arising out of this contract and covenants not to sue to Government of India as to any manner, claim, cause of action or thing whatsoever arising of or under this agreement.

**5. Transfer of Tender Documents:**

5.1 Transfer of Tender Documents purchased by one intending tenderer to another is not permissible.

**6. Earnest Money:**  
**(Clause not applicable for this Tender)**

6.1 The bidder must pay Earnest Money as given in the letter /notice inviting tenders and attach the official receipt with the tender failing which the tender is liable to be rejected and representatives of such tenderers will not be allowed to attend the tender opening. Earnest Money can be paid in Demand Drafts or Bank Guarantee or Banker's Cheque or Letter of Credit from any Indian scheduled bank or a branch of an International bank situated in India and registered with Reserve Bank of India as scheduled foreign bank. However, other than the Nationalized Indian Banks, the banks whose BGs are furnished, must be commercial banks having net worth in excess of Rs. 100 crores and a declaration to this effect should be made by such commercial bank either in the bank guarantee itself or separately on a letter head.

The bid guarantee shall be submitted in the prescribed format.

Note: The Bank Guarantee so furnished by the tenderer shall be in the proforma prescribed by the EMPLOYER. No interest shall be paid by the EMPLOYER on the Earnest Money deposited by the tenderer. The Bank Guarantee furnished in lieu of Earnest Money shall be kept valid for a period of "SIX MONTHS" from the date of opening of tender.(TWO MONTHS beyond the bid due date).

The Earnest Money deposited by successful tenderer shall be forfeited if the Contractor fails to furnish the requisite Contract Performance Security as per clause 24 hereof and /or fails to start work within a period of 15 days or fails to execute the AGREEMENT within 15 days of the receipt by him of the Notification of Acceptance of Tender.

Note: The Earnest Money of the unsuccessful bidder will be returned by EMPLOYER/CONSULTANT, directly to the tenderer(s), within a reasonable period of time but not later than 30 days after the expiration of the period of bid validity prescribed by EMPLOYER.

**7 Validity:**

7.1 Tender submitted by tenderers shall remain valid for acceptance for a period of "4 MONTHS" from the date of opening of the tender. The tenderers shall not be entitled during the said period of 4 months, without the consent in writing of the EMPLOYER, to revoke or cancel his tender or to vary the tender given or any term thereof. In case of tender revoking or canceling his tender or varying any term in regard thereof without the consent of EMPLOYER in writing, the EMPLOYER shall forfeit Earnest Money paid by him alongwith tender.

**8 Addenda/Corrigenda**

8.1 Addenda/ Corrigenda to the Tender Documents will be issued in duplicate prior to the date of opening of the tenders to clarify documents or to reflect modification in





**ELECTRICAL WORKS (SUPPLY & ERECTION)  
FOR ALTERNATE POWER SUPPLY  
ARRANGEMENT OF VIKARMPUR GUEST HOUSE  
AT TALCHER FERTILIZERS LTD., ANGUL, ODISHA  
GENERAL CONDITIONS OF CONTRACT**

PC-183 /E/8001/S-IV

0

DOC. NO.

REV.

Page 16 of 67



design or CONTRACT terms.

8.2 Each addenda/ corrigendum issued will be issued in duplicate to each person or organization to whom set of Tender Documents has been issued. Recipient will retain tenderer's copy of each Addendum/ Corrigendum and attach original copy duly signed along with his offer. All Addenda/ Corrigenda issued shall become part of Tender Documents.

**9 Right of Employer to Accept or Reject Tender:**

9.1 The right to accept the tender will rest with the EMPLOYER. The EMPLOYER, however, does not bind himself to accept the lowest tender, and reserves to itself the authority to reject any or all the tenders received without assigning any reason whatsoever. At the option of the Employer, the work for which the tender had been invited, may be awarded to one Contractor or split between more than one bidders, in which case the award will be made for only that part of the work, in respect of which the bid has been accepted. The quoted rates should hold good for such eventualities.

Tenders in which any of the particulars and prescribed information are missing or are incomplete in any respect and/or the prescribed conditions are not fulfilled are liable to be rejected. The Tender containing uncalled for remarks or any additional conditions are liable to be rejected.

Canvassing in connection with tenders is strictly prohibited and tenders submitted by the Tenderers who resort to canvassing will be liable to rejection.

**10 Time Schedule**

10.1 The WORK shall be executed strictly as per the TIME SCHEDULE specified in TENDER/ CONTRACT Document. The period of construction given in Time Schedule includes the time required for mobilization as well as testing, rectifications if any, retesting and completion in all respects to the entire satisfaction of the ENGINEER-IN- CHARGE.

10.2 A joint program of execution of the WORK will be prepared by the ENGINEER-IN-CHARGE and CONTRACTOR based on priority requirement of this project. This program will take into account the time of completion mentioned in 10.1 above and the time allowed for the priority works by the ENGINEER-IN-CHARGE.

10.3 Monthly/ Weekly construction program will; be drawn up by the ENGINEER-IN-CHARGE jointly with the CONTRACTOR, based on availability of work fronts and the joint construction program as per 10.2 above. The CONTRACTOR shall scrupulously adhere to these targets/ programs by deploying adequate personnel, construction tools and tackles and he shall also supply himself all materials of his scope of supply in good time to achieve the targets/program. In all matters concerning the extent of targets set out in the weekly and monthly programs and the degree of achievements the decision of the ENGINEER-IN-CHARGE will be final and binding on the CONTRACTOR.

**11 Tenderer's Responsibility**

11.1 The intending tenderers shall be deemed to have visited the SITE and familiarized submitting the tender. Non-familiarity with the site conditions will not be considered a reason either for extra claims or for not carrying out the works in strict conformity with the DRAWINGS and SPECIFICATIONS or for any delay in performance.

**12 Retired Government or Company Officers**

12.1 No Engineer of Gazetted rank or other Gazetted Officer employed in Engineering or Administrative duties in an Engineering Department of the States/ Central Government or of the EMPLOYER is allowed to work as a CONTRACTOR for a period of two years after his retirement from Government Service, or from the





**ELECTRICAL WORKS (SUPPLY & ERECTION)  
FOR ALTERNATE POWER SUPPLY  
ARRANGEMENT OF VIKARMPUR GUEST HOUSE  
AT TALCHER FERTILIZERS LTD., ANGUL, ODISHA  
GENERAL CONDITIONS OF CONTRACT**

PC-183 /E/8001/S-IV

0

DOC. NO.

REV.

Page 17 of 67



employment of the EMPLOYER without the previous permission of the EMPLOYER. The CONTRACT, if awarded, is liable to be cancelled if either the CONTRACTOR or any of his employees is found at any time to be such a person, who has not obtained the permission of the State/ Central Government or of the EMPLOYER as aforesaid before submission of tender, or engagement in the CONTRACTOR'S service as the case may be.

- 13 Signing of the Contract:**
- 13.1 The successful tenderer shall be required to execute an AGREEMENT in the proforma attached with TENDER DOCUMENT within 15 days of the receipt by him of the Notification of Acceptance of Tender. In the event of failure on the part of the successful tenderer to sign the AGREEMENT within the above stipulated period, the Earnest Money or his initial deposit will be forfeited and the acceptance of the tender shall be considered as cancelled.
- 14 Field Management & Controlling/Coordinating Authority:**
- 14.1 The field management will be the responsibility of the ENGINEER-IN-CHARGE, who will be nominated by the EMPLOYER. The ENGINEER-IN-CHARGE may also authorize his representatives to assist in performing his duties and functions.
- 14.2 The ENGINEER-IN-CHARGE shall coordinate the works of various agencies engaged at site to ensure minimum disruption of work carried out by different agencies. It shall be the responsibility of the CONTRACTOR to plan and execute the work strictly in accordance with site instructions to avoid hindrance to the work being executed by other agencies.
- 15 Note to Schedule of Rates:**
- 15.1 The Schedule of Rates should be read in conjunction with all the other sections of the tender.
- 15.2 The tenderer shall be deemed to have studied the DRAWINGS, SPECIFICATIONS and details of work to be done within TIME SCHEDULE and to have acquainted himself of the condition prevailing at site.
- 15.3 Rates must be filled in the Schedule of Rates of original Tender Documents. If quoted in separate typed sheets no variation in item description or specification shall be accepted. Any exceptions taken by the tenderer to the Schedule of Rates shall be brought out in the terms and conditions of the offer.
- 15.4 The quantities shown against the various items are only approximate. Any increase or decrease in the quantities shall not form the basis of alteration of the rates quoted and accepted.
- 15.5 The EMPLOYER reserves the right to interpolate the rates for such items of work falling between similar items of lower and higher magnitude.
- 16 Policy for Tenders Under Consideration:**
- 16.1 Only Those Tenders which are complete in all respects and are strictly in accordance with the Terms and Conditions and Technical Specifications of Tender Document, shall be considered for evaluation. Such Tenders shall be deemed to be under consideration immediately after opening of Tender and until such time an official intimation of acceptance/ rejection of Tender is made by TFL to the Bidder.
- 16.2 Zero Deviation: Bidders to note that this is a ZERO DEVIATION TENDER. TFL will appreciate submission of offer based on the terms and conditions in the enclosed General Conditions of Contract (GCC), Special Conditions of Contract (SCC), Instructions to Bidders (ITB), Scope of Work, technical specifications etc. to avoid wastage of time and money in seeking clarifications on technical/ commercial aspects of the offer. Bidder may note that no technical and commercial clarifications will be sought for after the receipt of the bids. In case of any deviation/ nonconformity observed in the bid, it will be liable for



**ELECTRICAL WORKS (SUPPLY & ERECTION)  
FOR ALTERNATE POWER SUPPLY  
ARRANGEMENT OF VIKARMPUR GUEST HOUSE  
AT TALCHER FERTILIZERS LTD., ANGUL, ODISHA  
GENERAL CONDITIONS OF CONTRACT**

PC-183 /E/8001/S-IV

0

DOC. NO.

REV.

Page 18 of 67



rejection.

- 17 Award of Contract:**
- 17.1 The Acceptance of Tender will be intimated to the successful Tenderer by TFL either by Telex/ Telegram/ Fax or by Letter or like means-defined as LETTER OF ACCEPTANCE OF TENDER.
- 17.2 TFL will be the sole judge in the matter of award of CONTRACT and the decision of TFL shall be final and binding.
- 18 Clarification of Tender Document:**
- 18.1 The Tender is required to carefully examine the Technical Specifications, Conditions of Contract, Drawings and other details relating to WORK and given in Tender Document and fully inform himself as to all conditions and matters which may in any way affect the WORK or the cost thereof. In case the Tenderer is in doubt about the completeness or correctness of any of the contents of the Tender Documents he should request in writing for an interpretation/ clarification to TFL in triplicate. TFL will then issue interpretation/ clarification to Tenderer in writing. Such clarifications and or interpretations shall form part of the Specifications and Documents and shall accompany the tender which shall be submitted by tenderer within time and date as specified in invitations to tender.
- 18.2 Verbal clarification and information given by TFL or its employee(s) or its representatives shall not in any way be binding on TFL.
- 19 Local Conditions:**
- 19.1 It will be imperative on each tenderer to inform himself of all local conditions and factors which may have any effect on the execution of WORK covered under the Tender Document. In their own interest, the tenderer are requested to familiarize themselves with the Indian Income Tax Act 1961, Indian Companies Act 1956, Indian Customs Act 1962 and other related Acts and Laws and Regulations of India with their latest amendments, as applicable TFL shall not entertain any requests for clarifications from the tenderer regarding such local conditions.
- 19.2 It must be understood and agreed that such factors have properly been investigated and considered while submitting the tender. No claim for financial or any other adjustments to VALUE OF CONTRACT, on lack of clarity of such factors shall be entertained.
- 20 Abnormal Rates:**
- 20.1 The tenderer is expected to quote rate for each item after careful analysis of cost involved for the performance of the completed item considering all specifications and Conditions of Contract. This will avoid loss of profit or gain in case of curtailment or change of specification for any item. In case it is noticed that the rates quoted by the tenderer for any item are unusually high or unusually low, it will be sufficient cause for the rejection of the tender unless the EMPLOYER is convinced about the reasonableness after scrutiny of the analysis for such rate(s) to be furnished by the tenderer (on demand).

**Section-IV. General Obligations**

- 21 Priority of Contract Documents**
- 21.1 Except if and the extent otherwise provided by the Contract, the provisions of the General Conditions of Contract and Special Conditions shall prevail over those of any other documents forming part of the CONTRACT. Several documents forming the CONTRACT are to be taken as mutually explanatory of one another, but in case of ambiguities or discrepancies the same shall be explained and adjusted by the ENGINEER-IN-CHARGE who shall thereupon issue to the Contractor instructions thereon and in such event, unless otherwise provided in the Contract, the priority of the documents forming the Contract shall be as follows :
- 1) The Contract Agreement ;
  - 2) The Letter of Acceptance;



**ELECTRICAL WORKS (SUPPLY & ERECTION)  
FOR ALTERNATE POWER SUPPLY  
ARRANGEMENT OF VIKARMPUR GUEST HOUSE  
AT TALCHER FERTILIZERS LTD., ANGUL, ODISHA  
GENERAL CONDITIONS OF CONTRACT**

PC-183 /E/8001/S-IV

0

DOC. NO.

REV.

Page 19 of 67



- 3) The Instructions to Bidders (ITB);
- 4) Special Conditions of Contract (SCC);
- 5) General Conditions of Contract (GCC)
- 6) Any other document forming part of the Contract.

Works shown in the DRAWING but not mentioned in the SPECIFICATIONS OR described in the SPECIFICATIONS without being shown in the DRAWINGS shall nevertheless be deemed to be included in the same manner as if they had been specifically shown upon the DRAWINGS and described in the SPECIFICATIONS.

21.2 Headings and Marginal Notes: All headings and marginal notes to the clauses of these General Conditions of Contract or to the SPECIFICATIONS or to any other Tender Document are solely for the purpose of giving a concise indication and not a summary of the contents thereof, and they shall never be deemed to be part thereof or be used in the interpretation or construction thereof the CONTRACT.

21.3 Singular and Plural: In CONTRACT DOCUMENTS unless otherwise stated specifically, the singular shall include the plural and vice versa wherever the context so requires.

21.4 Interpretation: Words implying 'Persons' shall include relevant 'Corporate Companies / Registered Associations/ Body of Individuals/ Firm of Partnership' as the case may be.

**22 Special Conditions of Contract:**

22.1 Special Conditions of Contract shall be read in conjunction with the General Conditions of Contract, specification of Work, Drawings and any other documents forming part of this CONTRACT wherever the context so requires.

22.2 Notwithstanding the sub-division of the documents into these separate sections and volumes every part of each shall be deemed to be supplementary to and complementary of every other part and shall be read with and into the CONTRACT so far as it may be practicable to do so.

22.3 Where any portion of the General Condition of Contract is repugnant to or at variance with any provisions of the Special Conditions of Contract, unless a different intention appears the provisions of the Special Conditions of Contract shall be deemed to over-ride the provisions of the General Conditions of Contract and shall to the extent of such repugnancy, or variations, prevail.

22.4 Wherever it is mentioned in the specifications that the CONTRACTOR shall perform certain WORK or provide certain facilities, it is understood that the CONTRACTOR shall do so at his cost and the VALUE OF CONTRACT shall be deemed to have included cost of such performance and provisions, so mentioned.

22.5 The materials, design and workmanship shall satisfy the relevant INDIAN STANDARDS, the JOB SPECIFICATIONS contained herein and CODES referred to. Where the job specification stipulate requirements in addition to those contained in the standard codes and specifications, these additional requirements shall also be satisfied.

**23 Contractor to obtain his own Information:**

23.1 The CONTRACTOR in fixing his rate shall for all purpose whatsoever reason may be, deemed to have himself independently obtained all necessary information for the purpose of preparing his tender and his tender as accepted shall be deemed to have taken into account all contingencies as may arise due to such information or lack of same. The correctness of the details, given in the Tender Document to help the CONTRACTOR to make up the tender is not guaranteed.



**ELECTRICAL WORKS (SUPPLY & ERECTION)  
FOR ALTERNATE POWER SUPPLY  
ARRANGEMENT OF VIKARMPUR GUEST HOUSE  
AT TALCHER FERTILIZERS LTD., ANGUL, ODISHA  
GENERAL CONDITIONS OF CONTRACT**

PC-183 /E/8001/S-IV

0

DOC. NO.

REV.

Page 20 of 67



The CONTRACTOR shall be deemed to have examined the CONTRACT DOCUMENTS, to have generally obtained his own information in all matters whatsoever that might affect the carrying out of the works at the scheduled rates and to have satisfied himself to the sufficiency of his tender. Any error in description of quantity or omission there from shall not vitiate the CONTRACT or release the CONTRACTOR from executing the work comprised in the CONTRACT according to DRAWINGS and SPECIFICATIONS at the scheduled rates. He is deemed to have known the scope, nature and magnitude of the WORKS and the requirements of materials and labour involved etc., and as to what all works he has to complete in accordance with the CONTRACT documents whatever be the defects, omissions or errors that may be found in the DOCUMENTS. The CONTRACTOR shall be deemed to have visited surroundings, to have satisfied himself to the nature of all existing structures, if any, and also as to the nature and the conditions of the Railways, Roads, Bridges and Culverts, means of transport and communication, whether by land, water or air, and as to possible interruptions thereto and the access and egress from the site, to have made enquiries, examined and satisfied himself as to the sites for obtaining sand, stones, bricks and other materials, the sites for disposal of surplus materials, the available accommodation as to whatever required, depots and such other buildings as may be necessary for executing and completing the works, to have made local independent enquiries as to the sub-soil, subsoil water and variations thereof, storms, prevailing winds, climatic conditions and all other similar matters effecting these works. He is deemed to have acquainted himself as to his liability of payment of Government Taxes, Customs duty and other charges, levies etc.

Any neglect or omission or failure on the part of the CONTRACTOR in obtaining necessary and reliable information upon the foregoing or any other matters affecting the CONTRACT shall not relieve him from any risks or liabilities or the entire responsibility from completion of the works at the scheduled rates and times in strict accordance with the CONTRACT.

It is, therefore, expected that should the CONTRACTOR have any doubt as to the meaning of any portion of the CONTRACT DOCUMENT he shall set forth the particulars thereof in writing to EMPLOYER in duplicate, before submission of tender. The EMPLOYER may provide such clarification as may be necessary in writing to CONTRACT, such clarifications as provided by EMPLOYER shall form part of CONTRACT DOCUMENTS.

No verbal agreement or inference from conversation with any effect or employee of the EMPLOYER either before, during or after the execution of the CONTRACT agreement shall in any way affect or modify and of the terms or obligations herein contained.

Any change in layout due to site conditions or technological requirement shall be binding on the CONTRACTOR and no extra claim on this account shall be entertained.

**24 Contract Performance Security:**

- 24.1 The CONTRACTOR shall furnish to the EMPLOYER, within 30 days from the date of notification of award, a security in the sum of 3% of the accepted value of the tender or the actual value of work to be done whichever is applicable due to any additional work or any other reasons, in the form of a Bank draft/Banker's cheque or Bank Guarantee or irrevocable Letter of credit (as per proforma enclosed) as Contract Performance Security with the EMPLOYER which will be refunded after the expiry of DEFECTS LIABILITY PERIOD.
- 24.2 CONTRACTOR can furnish the Contract Performance Security in the form of Demand Draft or through a Bank Guarantee or through an irrevocable Letter of Credit from any Indian scheduled bank or a branch of an International bank



**ELECTRICAL WORKS (SUPPLY & ERECTION)  
FOR ALTERNATE POWER SUPPLY  
ARRANGEMENT OF VIKARMPUR GUEST HOUSE  
AT TALCHER FERTILIZERS LTD., ANGUL, ODISHA  
GENERAL CONDITIONS OF CONTRACT**

PC-183 /E/8001/S-IV

0

DOC. NO.

REV.

Page 21 of 67



situated in India and registered with Reserve Bank of India as scheduled foreign bank. However, other than the Nationalized Indian Banks, the banks whose BGs are furnished, must be commercial banks having net worth in excess of Rs. 100 crores and a declaration to this effect should be made by such commercial bank either in the bank guarantee itself or separately on a letter head.

The bank guarantee or the Letter of Credit shall be submitted in the prescribed format.

- 24.3 If the CONTRACTOR/SUB-CONTRACTOR or their employees or the CONTRACTOR's agents and representatives shall damage, break, deface or destroy any property belonging to the EMPLOYER or others during the execution of the CONTRACT, the same shall be made good by the CONTRACTOR at his own expenses and in default thereof, the ENGINEER-IN-CHARGE may cause the same to be made good by other agencies and recover expenses from the CONTRACTOR (for which the certificate of the ENGINEER- IN-CHARGE shall be final).
- 24.4 All compensation or other sums of money payable by the CONTRACTOR to the EMPLOYER under terms of this CONTRACT may be deducted from or paid by the encashment or sale of a sufficient part of his Contract Performance Security or from any sums which may be due or may become due to the CONTRACTOR by the EMPLOYER of any account whatsoever and in the event of his Contract Performance Security being reduced by reasons of any such deductions or sale of aforesaid, the CONTRACTOR shall within ten days thereafter make good in cash, bank drafts as aforesaid any sum or sums which may have been deducted from or realized by sale of his Contract Performance Security, or any part thereof. No interest shall be payable by the EMPLOYER for sum deposited as Contract Performance Security.
- 24.5 Failure of the successful bidder to comply with the requirements of this Clause shall constitute sufficient grounds for the annulment of the award and the forfeiture of bid security.

**25 Time of Performance:**

**25.1 Time for Mobilization**

The work covered by this CONTRACT shall be commenced within fifteen (15) days, the date of letter/Fax of Intent and be completed in stages on or before the dates as mentioned in the TIME SCHEDULE OF COMPLETION OF WORK. The CONTRACTOR should bear in mind that time is the essence of this agreement. Request for revision of construction time after tenders are opened will not receive consideration. The above period of fifteen (15) days is included within the overall COMPLETION SCHEDULE, not over and above the completion time to any additional work or any other reasons.

**25.2 Time Schedule of Construction:**

25.2.1 The general Time Schedule of construction is given in the TENDER DOCUMENT. CONTRACTOR should prepare a detailed monthly or weekly construction program jointly with the ENGINEER-IN-CHARGE within 15 days of receipt of LETTER/FAX OF INTENT or ACCEPTANCE OF TENDER. The WORK shall be executed strictly as per the Time Schedule given in the CONTRACT DOCUMENT. The period of construction given includes the time required for mobilization testing, rectifications, if any, retesting and completion in all respects in accordance with CONTRACT DOCUMENT to the entire satisfaction of the ENGINEER-IN-CHARGE.

25.2.2 The CONTRACTOR shall submit a detailed PERT network within the time frame agreed above consisting of adequate number of activities covering various key



**ELECTRICAL WORKS (SUPPLY & ERECTION)  
FOR ALTERNATE POWER SUPPLY  
ARRANGEMENT OF VIKARMPUR GUEST HOUSE  
AT TALCHER FERTILIZERS LTD., ANGUL, ODISHA  
GENERAL CONDITIONS OF CONTRACT**

PC-183 /E/8001/S-IV

0

DOC. NO.

REV.

Page 22 of 67



phases of the WORK such as design, procurement, manufacturing, shipment and field erection activities within fifteen (15) days from the date of LETTER/FAX OF INTENT. This network shall also indicate the interface facilities to be provided by the EMPLOYER and the dates by which such facilities are needed.

25.2.3 CONTRACTOR shall discuss the network so submitted with the EMPLOYER and the agreed network which may be in the form as submitted with the EMPLOYER or in revised form in line with the outcome of discussions shall form part of the CONTRACT, to be signed within fifteen (15) days from the date of LETTER OF ACCEPTANCE OF TENDER. During the performance of the CONTRACT, if in the opinion of the EMPLOYER proper progress is not maintained suitable changes shall be made in the CONTRACTOR's operation to ensure proper progress.

The above PERT network shall be reviewed periodically and reports shall be submitted by the CONTRACTOR as directed by EMPLOYER.

**26 Force Majeure:**

**26.1 CONDITIONS FOR FORCE MAJEURES**

In the event of either party being rendered unable by Force Majeure to perform any obligations required to be performed by them under the CONTRACT the relative obligation of the party affected by such Force Majeures shall upon notification to the other party be suspended for the period during which Force Majeures event lasts. The cost and loss sustained by the either party shall be borne by the respective parties.

The term "Force Majeures" as employed herein shall mean acts of God, earthquake, war (declared or undeclared), revolts, riots, fires, floods, rebellions, explosions, hurricane, sabotage, civil commotions and acts and regulations of respective Government of the two parties, namely the EMPLOYER and the CONTRACTOR.

Upon the occurrence of such cause(s) and upon its termination, the party alleging that it has been rendered unable as aforesaid thereby, shall notify the other party in writing immediately but not later than 72 (Seventy-two) hours of the alleged beginning and ending thereof giving full particulars and satisfactory evidence in support of its claim.

Time for performance of the relative obligation suspended by the Force Majeures shall then stand extended by the period for which such cause lasts.

If deliveries of bought out items and/or works to be executed by the CONTRACTOR are suspended by Force Majeure conditions lasting for more than 2 (two) months the EMPLOYER shall have the option to terminate the CONTRACT or re-negotiate the contract provisions.

**26.2 OUTBREAK OF WAR**

26.2.1 If during the currency of the CONTRACT there shall be an out-break of war whether declared or not, in that part of the World which whether financially or otherwise materially affect the execution of the WORK the CONTRACTOR shall unless and until the CONTRACT is terminated under the provisions in this clause continue to use his best Endeavour to complete the execution of the WORK, provided always that the EMPLOYER shall be entitled, at any time after such out-break of war to terminate or re-negotiate the CONTRACT by giving notice in writing to the CONTRACTOR and upon such notice being given the CONTRACT shall, save as to the rights of the parties under this clause and to the operation of the clauses entitled settlement of Disputes and Arbitration hereof, be





**ELECTRICAL WORKS (SUPPLY & ERECTION)  
FOR ALTERNATE POWER SUPPLY  
ARRANGEMENT OF VIKARMPUR GUEST HOUSE  
AT TALCHER FERTILIZERS LTD., ANGUL, ODISHA  
GENERAL CONDITIONS OF CONTRACT**

PC-183 /E/8001/S-IV

0

DOC. NO.

REV.

Page 23 of 67



terminated but without prejudice to the right of either party in respect of any antecedent breach thereof.

26.2.2 If the CONTRACT shall be terminated under the provisions of the above clause, the CONTRACTOR shall with all reasonable diligence remove from the SITE all the CONTRACTOR's equipment and shall give similar facilities to his SUB-CONTRACTORS to do so.

**27 Price reduction schedule:**

27.1 Time is the essence of the CONTRACT. In case the CONTRACTOR fails to complete the WORK within the stipulated period, then, unless such failure is due to Force Majeure as defined in Clause 26 here above or due to EMPLOYER's defaults, the Total Contract price shall be reduced by ½ % of the total Contract Price per complete week of delay or part thereof subject to a maximum of 5 % of the Total Contract Price, by way of reduction in price for delay and not as penalty. The said amount will be recovered from amount due to the Contractor/ Contractor's Contract Performance Security payable on demand.

The decision of the OWNER in regard to applicability of Price Reduction Schedule shall be final and binding on the CONTRACTOR.

27.2 All sums payable under this clause is the reduction in price due to delay in completion period at the above agreed rate.

**27.3 BONUS FOR EARLY COMPLETION**

**Bonus For Early Completion  
27.3 (\*)**

If the Contractor achieves completion of Works in all respect prior to the time schedule stipulated in the SCC, the Employer shall pay to the Contractor the relevant sum, if mentioned specifically in SCC, as bonus for early completion. The bonus for early completion, if provided specifically in SCC, shall be payable to the maximum ceiling of 2 ½ % of the total contract price.

**(Clause not applicable for this Tender)**

(\*) Partial earlier completion may not always produce net benefits to the Employer, for example where utilization of the completed Works requires (a) the fulfillment of all parts of the Contract (e.g. the training of personnel); or (b) the completion of all Sections (e.g. in pipeline laying, where early completion of the laying of pipeline would not be useful if the compressor is still under installation); or (c) certain seasonal effects to take place (e.g. onset of the rainy season, for impounding a reservoir); or (d) other circumstances. Also a more rapid drawdown of budgeted funds may be required. All such factors should be considered prior to the inclusion of a bonus clause in the Contract.

**28 Rights of the employer to  
forfeit contract performance  
security:**

28.1 Whenever any claim against the CONTRACTOR for the payment of a sum of money arises out or under the CONTRACT, the EMPLOYER shall be entitled to recover such sum by appropriating in part or whole the Contract Performance Security of the CONTRACTOR. In the event of the security being insufficient or if no security has been taken from the CONTRACTOR, then the balance or the total sum recoverable, as the case may be shall be deducted from any sum then due or which at any time thereafter may become due to the CONTRACTOR. The CONTRACTOR shall pay to the EMPLOYER on demand any balance remaining due.

28.2 In case of forfeiture of Contract Performance Security/ Security Deposit, the forfeited amount will be considered inclusive of tax and tax invoice will be issued by TFL. The forfeiture amount will be subject to final decision of TFL based on other terms and conditions of order/ contract.

**29 Failure by the contractor to**

29.1 If the CONTRACTOR refuses or fails to execute the WORK or any separate part





**ELECTRICAL WORKS (SUPPLY & ERECTION)  
FOR ALTERNATE POWER SUPPLY  
ARRANGEMENT OF VIKARMPUR GUEST HOUSE  
AT TALCHER FERTILIZERS LTD., ANGUL, ODISHA  
GENERAL CONDITIONS OF CONTRACT**

PC-183 /E/8001/S-IV

0

DOC. NO.

REV.

Page 24 of 67



**comply with the provisions  
of the contract:**

thereof with such diligence as will ensure its completion within the time specified in the CONTRACT or extension thereof or fails to perform any of his obligation under the CONTRACT or in any manner commits a breach of any of the provisions of the CONTRACT it shall be open to the EMPLOYER at its option by written notice to the CONTRACTOR:

a) TO DETERMINE THE CONTRACT in which event the CONTRACT shall stand terminated and shall cease to be in force and effect on and from the date appointed by the EMPLOYER on that behalf, whereupon the CONTRACTOR shall stop forthwith any of the CONTRACTOR's work then in progress, except such WORK as the EMPLOYER may, in writing, require to be done to safeguard any property or WORK, or installations from damage, and the EMPLOYER, for its part, may take over the work remaining unfinished by the CONTRACTOR and complete the same through a fresh contractor or by other means, at the risk and cost of the CONTRACTOR, and any of his sureties if any, shall be liable to the EMPLOYER for any excess cost occasioned by such work having to be so taken over and completed by the EMPLOYER over and above the cost at the rates specified in the schedule of quantities and rate/prices.

b) WITHOUT DETERMINING THE CONTRACT to take over the work of the CONTRACTOR or any part thereof and complete the same through a fresh contractor or by other means at the risk and cost of the CONTRACTOR. The CONTRACTOR and any of his sureties are liable to the EMPLOYER for any excess cost over and above the cost at the rates specified in the Schedule of Quantities/ rates, occasioned by such works having been taken over and completed by the EMPLOYER.

29.2 In such events of Clause 29.1(a) or (b) above.

a) The whole or part of the Contract Performance Security furnished by the CONTRACTOR is liable to be forfeited without prejudice to the right of the EMPLOYER to recover from the CONTRACTOR the excess cost referred to in the sub-clause aforesaid, the EMPLOYER shall also have the right of taking possession and utilizing in completing the works or any part thereof, such as materials equipment and plants available at work site belonging to the CONTRACTOR as may be necessary and the CONTRACTOR shall not be entitled for any compensation for use or damage to such materials, equipment and plant.

b) The amount that may have become due to the CONTRACTOR on account of work already executed by him shall not be payable to him until after the expiry of Six (6) calendar months reckoned from the date of termination of CONTRACT or from the taking over of the WORK or part thereof by the EMPLOYER as the case may be, during which period the responsibility for faulty materials or workmanship in respect of such work shall, under the CONTRACT, rest exclusively with the CONTRACTOR. This amount shall be subject to deduction of any amounts due from the CONTRACT to the EMPLOYER under the terms of the CONTRACT authorized or required to be reserved or retained by the EMPLOYER.

29.3 Before determining the CONTRACT as per Clause 29.1(a) or (b) provided in the judgment of the EMPLOYER, the default or defaults committed by the CONTRACTOR is/are curable and can be cured by the CONTRACTOR if an opportunity given to him, then the EMPLOYER may issue Notice in writing



**ELECTRICAL WORKS (SUPPLY & ERECTION)  
FOR ALTERNATE POWER SUPPLY  
ARRANGEMENT OF VIKARMPUR GUEST HOUSE  
AT TALCHER FERTILIZERS LTD., ANGUL, ODISHA  
GENERAL CONDITIONS OF CONTRACT**

PC-183 /E/8001/S-IV

0

DOC. NO.

REV.

Page 25 of 67



calling the CONTRACTOR to cure the default within such time specified in the Notice.

- 29.4 The EMPLOYER shall also have the right to proceed or take action as per 29.1(a) or (b) above, in the event that the CONTRACTOR becomes bankrupt, insolvent, compounds with his creditors, assigns the CONTRACT in favour of his creditors or any other person or persons, or being a company or a corporation goes into voluntary liquidation, provided that in the said events it shall not be necessary for the EMPLOYER to give any prior notice to the CONTRACTOR.
- 29.5 Termination of the CONTRACT as provided for in sub- clause 29.1(a) above shall not prejudice or affect their rights of the EMPLOYER which may have accrued upto the date of such termination.
- 30 Contractor remains liable to pay compensation if action not taken under clause 29:**
- 30.1 In any case in which any of the powers conferred upon the EMPLOYER BY CLAUSE 29.0 thereof shall have become exercisable and the same had not been exercised, the non-exercise thereof shall not constitute a waiver of any of the conditions hereof and such powers shall notwithstanding be exercisable in .the event of any further case of default by the CONTRACTOR for which by any clause or clauses hereof he is declared liable to pay compensation amounting to the whole of his Contract Performance Security, and the liability of the CONTRACTOR for past and future compensation shall remain unaffected. In the event of the EMPLOYER putting in force the power under above sub-clause (a), (b) or (c) vested in him under the preceding clause he may, if he so desired, take possession of all or any tools, and plants, materials and stores in or upon the works or the site thereof belonging to the CONTRACTOR or procured by him and intended to be used for the execution of the WORK or any part thereof paying or allowing for the same in account at the CONTRACT rates or in case of these not being applicable at current market rates to be certified by the ENGINEER-IN-CHARGE whose certificate thereof shall be final, otherwise the ENGINEER-IN- CHARGE may give notice in writing to the CONTRACTOR or his clerk of the works, foreman or other authorized agent, requiring him to remove such tools, plant, materials or stores from the premises (within a time to be specified in such notice), and in the event of the CONTRACTOR failing to comply with any such requisition, the ENGINEER-IN-CHARGE may remove them at the CONTRACTOR's expense or sell them by auction or private sale on account of the CONTRACTOR and at his risk in all respects without any further notice as to the date, time or place of sale and the certificate of the ENGINEER-IN-CHARGE as to the expenses of any such removal and the amount of the proceeds and expenses of any such sale shall be final and conclusive against the CONTRACTOR.
- 31 Change in constitution:**
- 31.1 Where the CONTRACTOR is a partnership firm, the prior approval of the EMPLOYER shall be obtained in writing, before any change is made in the constitution of the firm. Where the CONTRACTOR is an individual or a Hindu undivided family business concern, such approval as aforesaid shall, likewise be obtained before such CONTRACTOR enters into any agreement with other parties, where under, the reconstituted firm would have the right to carry out the work hereby undertaken by the CONTRACTOR. In either case if prior approval as aforesaid is not obtained, the CONTRACT shall be deemed to have been allotted in contravention of clause 37 hereof and the same action may be taken and the same consequence shall ensue as provided in the said clause.
- 32 Termination of contract**
- 32(A) **TERMINATION OF CONTRACT FOR DEATH:**  
If the CONTRACTOR is an individual or a proprietary concern and the individual or the proprietor dies or if the CONTRACTOR is a partnership concern and one of the partner dies then unless, the EMPLOYER is satisfied that the legal representative of the individual or the proprietary concern or the



**ELECTRICAL WORKS (SUPPLY & ERECTION)  
FOR ALTERNATE POWER SUPPLY  
ARRANGEMENT OF VIKARMPUR GUEST HOUSE  
AT TALCHER FERTILIZERS LTD., ANGUL, ODISHA  
GENERAL CONDITIONS OF CONTRACT**

PC-183 /E/8001/S-IV

0

DOC. NO.

REV.

Page 26 of 67



surviving partners are capable of carrying out and completing CONTRACT, he (the EMPLOYER) is entitled to cancel the CONTRACT for the uncompleted part without being in any way liable for any compensation payment to the estate of the diseased CONTRACTOR and/or to the surviving partners of the CONTRACTOR'S firm on account of the cancellation of CONTRACT. The decision of the EMPLOYER in such assessment shall be final and binding on the parties. In the event of such cancellation, the EMPLOYER shall not hold the estate of the diseased CONTRACTOR and/or the surviving partners of the CONTRACTOR'S firm liable for any damages for non-completion of CONTRACT.

**32(B) TERMINATION OF CONTRACT IN CASE OF LIQUIDATION / BANKRUPTCY ETC.**

If the Contractor shall dissolve or become bankrupt or insolvent or cause or suffer any receiver to be appointed of his business of any assets thereof compound with his Creditors, or being a corporation commence to be wound up, not being a member's voluntary winding up for the purpose of amalgamation or reconstruction, or carry on its business under a Receiver for the benefits of its Creditors any of them, EMPLOYER shall be at liberty :-

To terminate the contract forthwith upon coming to know of the happening of any such event as aforesaid by notice in writing to the Contractor or to give the Receiver or liquidator or other person, the option of carrying out the contract subject to his providing a guarantee up to an amount to be agreed upon by EMPLOYER for due and faithful performance of the contract.

**32 (C) In case of termination of CONTRACT herein set forth (under clause 29.0) except under conditions of Force Majeure and termination after expiry of contract, the CONTRACTOR shall be put under holiday [i.e. neither any enquiry will be issued to the party by Talcher Fertilizers Ltd. against any type of tender nor their offer will be considered by TFL against any ongoing tender (s) where contract between TFL and that particular CONTRACTOR (as a bidder) has not been finalized] for three years from the date of termination by Talcher Fertilizers Ltd. to such CONTRACTOR.**

**33 Members of the employer not individually liable :**

33.1 No Director, or official or employee of the EMPLOYER/ CONSULTANT shall in any way be personally bound or liable for the acts or obligations of the EMPLOYER under the CONTRACT or answerable for any default or omission in the observance or performance of any of the acts, matters or things which are herein contained.

**34 Employer not bound by personal representations:**

34.1 The CONTRACTOR shall not be entitled to any increase on the scheduled rates or any other right or claim whatsoever by reason of any representation, explanation statement or alleged representation, promise or guarantees given or alleged to have been given to him by any person.

**35 Contractor's office at site:**

35.1 The CONTRACTOR shall provide and maintain an office at the site for the accommodation of his agent and staff and such office shall be open at all reasonable hours to receive instructions, notice or other communications. The CONTRACTOR at all time shall maintain a site instruction book and compliance of these shall be communicated to the ENGINEER-IN CHARGE from time to time and the whole document to be preserved and handed over after completion of works.

**36 Contractor's subordinate**

36.1 The CONTRACTOR, on or after award of the WORK shall name and depute a



**ELECTRICAL WORKS (SUPPLY & ERECTION)  
FOR ALTERNATE POWER SUPPLY  
ARRANGEMENT OF VIKARMPUR GUEST HOUSE  
AT TALCHER FERTILIZERS LTD., ANGUL, ODISHA  
GENERAL CONDITIONS OF CONTRACT**

PC-183 /E/8001/S-IV

0

DOC. NO.

REV.

Page 27 of 67



**staff and their conduct**

qualified engineer having sufficient experience in carrying out work of similar nature, to whom the equipments, materials, if any, shall be issued and instructions for works given. The CONTRACTOR shall also provide to the satisfaction of the ENGINEER-IN-CHARGE sufficient and qualified staff to superintend the execution of the WORK, competent sub-agents, foremen and leading hands including those specially qualified by previous experience to supervise the types of works comprised in the CONTRACT in such manner as will ensure work of the best quality, expeditious working. Whenever in the opinion of the ENGINEER-IN-CHARGE additional properly qualified supervisory staff is considered necessary, they shall be employed by the CONTRACTOR without additional charge on accounts thereof. The CONTRACTOR shall ensure to the satisfaction of the ENGINEER-IN-CHARGE that SUB-CONTRACTORS, if any, shall provide competent and efficient supervision, over the work entrusted to them.

36.2 If and whenever any of the CONTRACTOR's or SUB- CONTRACTOR'S agents, sub-agents, assistants, foremen, or other employees shall in the opinion of ENGINEER-IN- CHARGE be guilty of any misconduct or be incompetent or insufficiently qualified or negligent in the performance of their duties of that in the opinion of the EMPLOYER or the ENGINEER-IN-CHARGE, it is undesirable for administrative or any other reason for such person or persons to be employed in the works, the CONTRACTOR, is so directed by the ENGINEER-IN-CHARGE, shall at once remove such person or persons from employment thereon. Any person or persons so removed from the works shall not again be employed in connection with the WORKS without the written permission of the ENGINEER-IN- CHARGE. Any person so removed from the WORK shall be immediately re-placed at the expense of the CONTRACTOR by a qualified and competent substitute. Should the CONTRACTOR be requested to repatriate any person removed from the works he shall do so and shall bear all costs in connection herewith.

36.3 The CONTRACTOR shall be responsible for the proper behavior of all the staff, foremen, workmen, and others, and shall exercise a proper degree of control over them and in particular and without prejudice to the said generality, the CONTRACTOR shall be bound to prohibit and prevent any employees from trespassing or acting in any way detrimental or prejudicial to the interest of the community or of the properties or occupiers of land and properties in the neighborhood and in the event of such employee so trespassing, the CONTRACTOR shall be responsible therefore and relieve the EMPLOYER of all consequent claims or actions for damages or injury or any other grounds whatsoever. The decision of the ENGINEER-IN-CHARGE upon any matter arising under this clause shall be final. The CONTRACTOR shall be liable for any liability to EMPLOYER on account of deployment of CONTRACTOR's staff etc. or incidental or arising out of the execution of CONTRACT.

The CONTRACTOR shall be liable for all acts or omissions on the part of his staff, Foremen and Workmen and others in his employment, including misfeasance or negligence of whatever kind in the course of their work or during their employment, which are connected directly or indirectly with the CONTRACT.

36.4 If and when required by the EMPLOYER and CONTRACTOR's personnel entering upon the EMPLOYER's premises shall be properly identified by badges of a type acceptable to the EMPLOYER which must be worn at all times on EMPLOYER's premises. CONTRACTOR may be required to obtain daily entry passes for his staff/employees from EMPLOYER to work within operating areas. These being safety requirements, no relaxations on this account shall be given to CONTRACTOR.



**ELECTRICAL WORKS (SUPPLY & ERECTION)  
FOR ALTERNATE POWER SUPPLY  
ARRANGEMENT OF VIKARMPUR GUEST HOUSE  
AT TALCHER FERTILIZERS LTD., ANGUL, ODISHA  
GENERAL CONDITIONS OF CONTRACT**

PC-183 /E/8001/S-IV

0

DOC. NO.

REV.

Page 28 of 67



**37 Sub-letting of works:**

37.1

No part of the CONTRACT nor any share or interest therein shall in any manner or degree be transferred, assigned or sublet by the CONTRACTOR directly or indirectly to any person, firm or corporation whatsoever without the consent in writing, of the ENGINEER/ EMPLOYER except as provided for in the succeeding sub-clause.

**i) SUB-CONTRACTS FOR TEMPORARY WORKS ETC.:**

The EMPLOYER may give written consent to Sub- contract for the execution of any part of the WORK at the site, being entered in to by CONTRACTOR provided each individual Sub- contract is submitted to the ENGINEER-IN-CHARGE before being entered into and is approved by him.

**ii) LIST OF SUB-CONTRACTORS TO BE SUPPLIED:**

At the commencement of every month the CONTRACTOR shall furnish to the ENGINEER-IN- CHARGE list of all SUB-CONTRACTORS or other persons or firms engaged by the CONTRACTOR and working at the SITE during the previous month with particulars of the general nature of the Subcontract or works done by them.

**iii) CONTRACTOR'S LIABILITY NOT LIMITED BY SUB-CONTRACTORS:**

Notwithstanding any sub-letting with such approval as aforesaid and notwithstanding that the ENGINEER-IN-CHARGE shall have received copies of any Subcontracts, the contractor shall be and shall remain solely responsible for the quality, proper and expeditious execution of the Contract in all respects as if such sub-letting or Subcontracting had not taken place, and as if such work had been done directly by the CONTRACTOR. The CONTRACTOR shall bear all responsibility for any act or omission on the part of sub-contractors in regard to work to be performed under the CONTRACT.

**iv) EMPLOYER MAY TERMINATE SUB-CONTRACTS:**

If any SUB-CONTRACTOR engaged upon the works at the site executes any works which in the opinion of the ENGINEER-IN-CHARGE is not in accordance with the CONTRACT documents, the EMPLOYER may by written notice to the CONTRACTOR request him to terminate such subcontract and the CONTRACTOR upon the receipt of such notice shall terminate such Subcontract and dismiss the SUB-CONTRACTOR(S) and the later shall forthwith leave the works, failing which the EMPLOYER shall have the right to remove such SUB- CONTRACTOR(S) from the site.

**v) NO REMEDY FOR ACTION TAKEN UNDER THIS CLAUSE:**

No action taken by the EMPLOYER under the clause shall relieve the CONTRACTOR of any of his liabilities under the CONTRACT or give rise to any right or compensation, extension of time or otherwise failing which the EMPLOYER shall have the right to remove such SUB-CONTRACTOR(S) from the site.



**ELECTRICAL WORKS (SUPPLY & ERECTION)  
FOR ALTERNATE POWER SUPPLY  
ARRANGEMENT OF VIKARMPUR GUEST HOUSE  
AT TALCHER FERTILIZERS LTD., ANGUL, ODISHA  
GENERAL CONDITIONS OF CONTRACT**

PC-183 /E/8001/S-IV

0

DOC. NO.

REV.

Page 29 of 67



**38 Power of entry:**

38.1 If the CONTRACTOR shall not commence the WORK in the manner previously described in the CONTRACT documents or if he shall at any time in the opinion of the ENGINEER-IN-CHARGE.

- i) fail to carry out the WORK in conformity with the CONTRACT documents, or
- ii) fail to carry out the WORK in accordance with the Time Schedule, or
- iii) substantially suspend work or the WORK for a period of fourteen days without authority from the ENGINEER-IN-CHARGE, or
- iv) fail to carry out and execute the WORK to the satisfaction of the ENGINEER-IN-CHARGE, or
- v) fail to supply sufficient or suitable construction plant, temporary works, labour, materials or things, or
- vi) Commit, suffer, or permit any other breach of any of the provisions of the CONTRACT on his part to be performed or observed or persist in any of the above mentioned breaches of the CONTRACT for fourteen days, after notice in writing shall have been given to the CONTRACTOR by the ENGINEER-IN-CHARGE requiring such breach to be remedied, or
- vii) if the CONTRACTOR shall abandon the WORK or
- viii) If the CONTRACTOR during the continuance of the CONTRACT shall become bankrupt, make any arrangement or composition with his creditors, or permit any execution to be levied or go into liquidation whether compulsory or voluntary not being merely a voluntary liquidation for the purpose of amalgamation or reconstruction

then in any such case, the EMPLOYER shall have the power to enter upon the WORK and take possession thereof and of the materials, temporary WORK, construction plant, and stock thereon, and to revoke the CONTRACTOR's license to use the same, and to complete the WORK by his agents, other CONTRACTORS or workmen or to relate the same upon any terms and to such other person, firm or corporation as the EMPLOYER in his absolute discretion may think proper to employ and for the purpose aforesaid to use or authorize the use of any materials, temporary work, CONSTRUCTION PLANT, and stock as aforesaid, without making payment or allowance to the CONTRACTOR for the said materials other than such as may be certified in writing by the ENGINEER-IN-CHARGE to be reasonable, and without making any payment or allowance to the CONTRACTOR for the use of the temporary said works, construction plant and stock or being liable for any loss or damage thereto, and if the EMPLOYER shall by reason of his taking possession of the WORK or of the WORK being completed by other CONTRACTOR (due account being taken of any such extra work or works which may or be omitted) then the amount of such excess as certified by the ENGINEER-IN-CHARGE shall be deducted from any money which may be due for work done by the CONTRACTOR under the CONTRACT and not paid for. Any deficiency shall forthwith be made good and





**ELECTRICAL WORKS (SUPPLY & ERECTION)  
FOR ALTERNATE POWER SUPPLY  
ARRANGEMENT OF VIKARMPUR GUEST HOUSE  
AT TALCHER FERTILIZERS LTD., ANGUL, ODISHA  
GENERAL CONDITIONS OF CONTRACT**

PC-183 /E/8001/S-IV

0

DOC. NO.

REV.

Page 30 of 67



paid to the EMPLOYER by the CONTRACTOR and the EMPLOYER shall have power to sell in such manner and for such price as he may think fit all or any of the construction plant, materials etc. constructed by or belonging to and to recoup and retain the said deficiency or any part thereof out of proceeds of the sale.

**39 Contractor's responsibility with the mechanical, electrical, intercommunication system, air-conditioning contractors and other agencies:**

39.1

Without repugnance of any other condition, it shall be the responsibility of the CONTRACTOR executing the work of civil construction, to work in close cooperation and coordinate the WORK with the Mechanical, Electrical, Air-conditioning and Intercommunication Contractor's and other agencies or their authorized representatives, in providing the necessary grooves, recesses, cuts and opening etc., in wall, slabs beams and columns etc. and making good the same to the desired finish as per specification, for the placement of electrical, intercommunication cables, conduits, air-conditioning inlets and outlets grills and other equipments etc. where required. For the above said requirements in the false ceiling and other partitions, the CONTRACTOR before starting-up the work shall in consultation with the Electrical, Mechanical, Intercommunication, Air-conditioning contractor and other agencies prepare and put-up a joint scheme, showing the necessary openings, grooves, recesses, cuts, the methods of fixing required for the WORK of the aforesaid, and the finishes therein, to the ENGINEER-IN-CHARGE and get the approval. The CONTRACTOR before finally submitting the scheme to the ENGINEER-IN-CHARGE, shall have the written agreement of the other agencies. The ENGINEER- IN-CHARGE, before communicating his approval to the scheme, with any required modification, shall get the final agreement of all the agencies, which shall be binding. No claim shall be entertained on account of the above.

The CONTRACTOR shall confirm in all respects with provision of any statutory regulations, ordinances or byelaws of any local or duly constituted authorities or public bodies which may be applicable from time to time to the WORK or any temporary works. The CONTRACTOR shall keep the EMPLOYER indemnified against all penalties and liabilities of every kind, arising out of non- adherence to such stains, ordinances, laws, rules, regulations, etc.

**40 Other agencies at site:**

40.1

The CONTRACTOR shall have to execute the WORK in such place and conditions where other agencies will also be engaged for other works such as site grading, filling, and leveling, electrical and mechanical engineering works, etc. No claim shall be entertained due to WORK being executed in the above circumstances.

**41 Notice:**

41.1

TO THE CONTRACTOR:

Any notice hereunder may be served on the CONTRACTOR or his duly authorized representative at the job site or may be served by registered mail direct to the address furnished by the CONTRACTOR. Proof of issue of any such notice could be conclusive of the CONTRACTOR having been duly informed of all contents therein.

41.2

TO THE EMPLOYER:

Any notice to be given to the EMPLOYER under the terms of the CONTRACTOR shall be served by sending the same by Registered mail to or delivering the same at the respective site offices of M/s Talcher Fertilizers Ltd. addressed to the HEAD/SITE-IN-CHARGE.

**42 Right of various interests:**

i)

The EMPLOYER reserves the right to distribute the work between more than one agency(ies). The CONTRACTOR shall cooperate and afford other agency(ies) reasonable opportunity for





**ELECTRICAL WORKS (SUPPLY & ERECTION)  
FOR ALTERNATE POWER SUPPLY  
ARRANGEMENT OF VIKARMPUR GUEST HOUSE  
AT TALCHER FERTILIZERS LTD., ANGUL, ODISHA  
GENERAL CONDITIONS OF CONTRACT**

PC-183 /E/8001/S-IV

0

DOC. NO.

REV.

Page 31 of 67



access to the WORK for the carriage and storage of materials and execution of their works.

- ii) Wherever the work being done by any department of the EMPLOYER or by other agency(ies) employed by the EMPLOYER is contingent upon WORK covered by this CONTRACT, the respective rights of the various interests involved shall be determined by the ENGINEER-IN-CHARGE to secure the completion of the various portions of the work in general harmony.

**43 Patents and royalties:**

- 43.1 The CONTRACTOR, if licensed under any patent covering equipment, machinery, materials or compositions of matter to be used or supplied or methods and process to be practiced or employed in the performance of this CONTRACT, agrees to pay all royalties and license fees which may be due with respect thereto. If any equipment, machinery, materials, composition of matters, be used or supplied or methods and processes to be practiced or employed in the performance of this CONTRACT, is covered by a patent under which the CONTRACTOR is not licensed then the CONTRACTOR before supplying or using the equipment, machinery materials, composition method or processes shall obtain such licenses and pay such royalties and license fees as may be necessary for performance of this CONTRACT. In the event the CONTRACTOR fails to pay any such royalty or obtain any such license, any suit for infringement of such patents which is brought against the CONTRACTOR or the EMPLOYER as a result such failure will be defended by the CONTRACTOR at his own expense and the CONTRACTOR will pay any damages and costs awarded in such suit. The CONTRACTOR shall promptly notify the EMPLOYER if the CONTRACTOR has acquired the knowledge of any plant under which a suit for infringement could be reasonably brought because of the use by the EMPLOYER of any equipment, machinery, materials, process, methods to be supplied hereunder. The CONTRACTOR agrees to and does hereby grant to EMPLOYER, together with the right to extend the same to any of the subsidiaries of the EMPLOYER as irrevocable, royalty free license to use in any country, any invention made by the CONTRACTOR or his employee in or as result of the performance of the WORK under the CONTRACT.
- 43.2 All charges on account of royalty, tollage, rent, octroi terminal or sales tax and/ or other duties or any other levy on materials obtained for the work or temporary work or part thereof (excluding materials provided by the EMPLOYER) shall be borne by the CONTRACTOR.
- 43.3 The CONTRACTOR shall not sell or otherwise dispose of or remove except for the purpose of this CONTRACT, the sand, stone, clay, ballast, earth, rock or other substances, or materials obtained from any excavation made for the purpose of the WORK or any building or produce upon the site at the time of delivery of the possession thereof, but all such substances, materials, buildings and produce shall be the property of the EMPLOYER provided that the CONTRACTOR may with the permission of the ENGINEER-IN-CHARGE, use the same for the purpose of the work by payment of cost of the same at such a rate as may be determined by the ENGINEER-IN- CHARGE.
- 43.4 The EMPLOYER shall indemnify and save harmless the CONTRACTOR from any loss on account of claims against CONTRACTOR for the contributory infringement of patent rights arising out and based upon the claim that the use of the EMPLOYER of the process included in the design prepared by the EMPLOYER and used in the operation of the plant infringes on any patent right. With respect to any subcontract entered into by CONTRACTOR pursuant to the provisions of the relevant clause hereof, the CONTRACTOR shall obtain from the SUB-CONTRACTOR an undertaking to provide the EMPLOYER with the same



**ELECTRICAL WORKS (SUPPLY & ERECTION)  
FOR ALTERNATE POWER SUPPLY  
ARRANGEMENT OF VIKARMPUR GUEST HOUSE  
AT TALCHER FERTILIZERS LTD., ANGUL, ODISHA  
GENERAL CONDITIONS OF CONTRACT**

PC-183 /E/8001/S-IV

0

DOC. NO.

REV.

Page 32 of 67



patent protection that CONTRACTOR is required to provide under the provisions of this clause.

**44 Liens:**

- 44.1 If, at any time there should be evidence or any lien or claim for which the EMPLOYER might have become liable and which is chargeable to the CONTRACTOR, the EMPLOYER shall have the right to retain out of any payment then due or thereafter to become due an amount sufficient to completely indemnify the EMPLOYER against such lien or claim and if such lien or claim be valid, the EMPLOYER may pay and discharge the same and deduct the amount so paid from any money which may be or may become due and payable to the CONTRACTOR. If any lien or claim remain unsettled after all payments are made, the CONTRACTOR shall refund or pay to the EMPLOYER all money that the latter may be compelled to pay in discharging such lien or claim including all costs and reasonable expenses. EMPLOYER reserves the right to do the same.
- 44.2 The EMPLOYER shall have lien on all materials, equipments including those brought by the CONTRACTOR for the purpose of erection, testing and commissioning of the WORK.
- 44.3 The final payment shall not become due until the CONTRACTOR delivers to the ENGINEER-IN-CHARGE a complete release or waiver of all liens arising or which may arise out of his agreement or receipt in full or certification by the CONTRACTOR in a form approved by ENGINEER-IN-CHARGE that all invoices for labour, materials, services have been paid in lien thereof and if required by the ENGINEER-IN-CHARGE in any case an affidavit that so far as the CONTRACTOR has knowledge or information the releases and receipts include all the labour and material for which a lien could be filled.
- 44.4 CONTRACTOR will indemnify and hold the EMPLOYER harmless, for a period of two years after the issue of FINAL CERTIFICATE, from all liens and other encumbrances against the EMPLOYER on account of debts or claims alleged to be due from the CONTRACTOR or his SUB-CONTRACTOR to any person including SUB- CONTRACTOR and on behalf of EMPLOYER will defend at his own expense, any claim or litigation brought against the EMPLOYER or the CONTRACTOR in connection therewith. CONTRACTOR shall defend or contest at his own expense any fresh claim or litigation by any person including his SUB-CONTRACTOR, till its satisfactory settlement even after the expiry of two years from the date of issue of FINAL CERTIFICATE.

**45 Delays by employer or his authorized agents:**

- 45.1 In case the CONTRACTOR's performance is delayed due to any act or omission on the part of the EMPLOYER or his authorized agents, then the CONTRACTOR shall be given due extension of time for the completion of the WORK, to the extent such omission on the part of the EMPLOYER has caused delay in the CONTRACTOR's performance of his WORK.
- 45.2 No adjustment in CONTRACT PRICE shall be allowed for reasons of such delays and extensions granted except as provided in TENDER DOCUMENT, where the EMPLOYER reserves the right to seek indulgence of CONTRACTOR to maintain the agreed Time Schedule of Completion.

In such an event the CONTRACTOR shall be obliged for working by CONTRACTOR's personnel for additional time beyond stipulated working hours as also Sundays and Holidays and achieve the completion date/interim targets.

**46 Payment if the contract is terminated:**

- 46.1 If the CONTRACT shall be terminated as per Tender pursuant to Clause no. 29 of GCC, the CONTRACTOR shall be paid by the EMPLOYER in so far as such amounts or items shall not have already been covered by payments of amounts made to the CONTRACTOR for the WORK executed and accepted by



**ELECTRICAL WORKS (SUPPLY & ERECTION)  
FOR ALTERNATE POWER SUPPLY  
ARRANGEMENT OF VIKARMPUR GUEST HOUSE  
AT TALCHER FERTILIZERS LTD., ANGUL, ODISHA  
GENERAL CONDITIONS OF CONTRACT**

PC-183 /E/8001/S-IV

0

DOC. NO.

REV.

Page 33 of 67



ENGINEER-IN-CHARGE prior to the date of termination at the rates and prices provided for in the CONTRACT and in addition to the following:

a) The amount payable in respect of any preliminary items, so far as the Work or service comprised therein has been carried out or performed and an appropriate portion as certified by ENGINEER-IN-CHARGE of any such items or service comprised in which has been partially carried out or performed.

b) Any other expenses which the CONTRACTOR has expended for performing the WORK under the CONTRACT subject to being duly recommended by ENGINEER-IN-CHARGE and approved by EMPLOYER for payment, based on documentary evidence of his having incurred such expenses.

46.2 The CONTRACTOR will be further required to transfer the title and provide the following in the manner and as directed by the EMPLOYER.

a) Any and all completed works.

b) Such partially completed WORK including drawings, information's and CONTRACT rights as the CONTRACTOR has specially performed, produced or acquired for the performance of the CONTRACTOR.

**47 No waiver of rights:**

47.1 Neither the inspection by the EMPLOYER or any of their officials, employees, or agents nor any order by the EMPLOYER for payment of money or any payment for or acceptance of the whole or any part of the Work by the EMPLOYER nor any extension of time, nor any possession taken by EMPLOYER shall operate as a waiver of any provision of the CONTRACT, or of any power herein reserved to the EMPLOYER, or any right to damages herein provided, nor shall any waiver of any breach in the CONTRACT be held to be a waiver of any other subsequent breach.

**48 Certificate not to affect right of employer and liability of contractor:**

48.1 No interim payment certificate(s) issued by the Engineer-in-Charge of the EMPLOYER, nor any sum paid on account by the EMPLOYER, nor any extension of time for execution of the work granted by EMPLOYER shall affect or prejudice the rights of the Employer against the CONTRACTOR or relieve the CONTRACTOR of his obligations for the due performance of the CONTRACT, or be interpreted as approval of the WORK done or of the equipment supplied and no certificate shall create liability for the EMPLOYER to pay for alterations, amendments, variations or additional works not ordered, in writing, by EMPLOYER or discharge the liability of the CONTRACTOR for the payment of damages whether due, ascertained, or certified or not or any sum against the payment of which he is bound to indemnify the EMPLOYER.

**49 Language and measures:**

49.1 All documents pertaining to the CONTRACT including Specifications, Schedules, Notices, Correspondence, operating and maintenance Instructions, DRAWINGS, or any other writing shall be written in English language. The Metric System of measurement shall be used in the CONTRACT unless otherwise specified.

**50 Transfer of title:**

50.1 The title of Ownership of supplies furnished by the CONTRACTOR shall not pass on to the EMPLOYER for all Supplies till the same are finally accepted by the EMPLOYER after the successful completion of PERFORMANCE TEST and GUARANTEE TEST and issue of FINAL CERTIFICATE.



**ELECTRICAL WORKS (SUPPLY & ERECTION)  
FOR ALTERNATE POWER SUPPLY  
ARRANGEMENT OF VIKARMPUR GUEST HOUSE  
AT TALCHER FERTILIZERS LTD., ANGUL, ODISHA  
GENERAL CONDITIONS OF CONTRACT**

PC-183 /E/8001/S-IV

0

DOC. NO.

REV.

Page 34 of 67



- 50.2 However, the EMPLOYER shall have the lien on all such works performed as soon as any advance or progressive payment is made by the EMPLOYER to the CONTRACTOR and the CONTRACTOR shall not subject these works for use other than those intended under this CONTRACT.
- 51 Release of information:** 51.1 The CONTRACTOR shall not communicate or use in advertising, publicity, sales releases or in any other medium, photographs, or other reproduction of the Work under this CONTRACT or description of the site dimensions, quantity, quality or other information, concerning the Work unless prior written permission has been obtained from the EMPLOYER.
- 52 Brand names:** 52.1 The specific reference in the SPECIFICATIONS and documents to any material by trade name, make or catalogue number shall be construed as establishing standard or quality and performance and not as limited competition. However, TENDERER may offer other similar equipments provided it meets the specified standard design and performance requirements.
- 53 Completion of contract:** 53.1 Unless otherwise terminated under the provisions of any other relevant clause, this CONTRACT shall be deemed to have been completed at the expiration of the PERIOD OF LIABILITY as provided for under the CONTRACT.
- 54 Spares:** 54.1 The CONTRACTOR shall furnish to the EMPLOYER all spares required for COMMISSIONING of the plants, recommendatory and/or mandatory spares, which are required essential by the manufacturer/supplier. The same shall be delivered at SITE, 3(Three) months before COMMISSIONING.

Also the CONTRACTOR should furnish the manufacturing drawings for fast wearing spares.

- 54.2 The CONTRACTOR guarantees the EMPLOYER that before the manufacturers of the equipments, plants and machineries go out of production of spare parts for the equipment furnished and erected by him, he shall give at least twelve (12) months' advance notice to the EMPLOYER, so that the latter may order his requirement of spares in one lot, if he so desires.

**SECTION-V Performance of Work**

- 55 Execution of work:** 55.1 All the Works shall be executed in strict conformity with the provisions of the CONTRACT Documents and with such explanatory detailed drawings, specification and instructions as may be furnished from time to time to the CONTRACTOR by the ENGINEER-IN-CHARGE whether mentioned in the CONTRACT or not. The CONTRACTOR shall be responsible for ensuring that works throughout are executed in the most substantial, proper and workmanlike manner with the quality of material and workmanship in strict accordance with the SPECIFICATIONS and to the entire satisfaction of the ENGINEER-IN-CHARGE. The CONTRACTOR shall provide all necessary materials equipment labour etc. for execution and maintenance of WORK till completion unless otherwise mentioned in the CONTRACT.
- 56 Co-ordination and inspection of work:** 56.1 The coordination and inspection of the day-to-day work under the CONTRACT shall be the responsibility of the ENGINEER-IN-CHARGE. The written instruction regarding any particular job will normally be passed by the ENGINEER-IN-CHARGE or his authorized representative. A work order book will be maintained by the CONTRACTOR for each sector in which the aforesaid written instructions will be entered. These will be signed by the CONTRACTOR or his authorized representative by way of acknowledgement within 12 hours.



**ELECTRICAL WORKS (SUPPLY & ERECTION)  
FOR ALTERNATE POWER SUPPLY  
ARRANGEMENT OF VIKARMPUR GUEST HOUSE  
AT TALCHER FERTILIZERS LTD., ANGUL, ODISHA  
GENERAL CONDITIONS OF CONTRACT**

PC-183 /E/8001/S-IV

0

DOC. NO.

REV.

Page 35 of 67



- 57 Work in monsoon and dewatering:**
- 57.1 Unless otherwise specified elsewhere in the tender, the execution of the WORK may entail working in the monsoon also. The CONTRACTOR must maintain a minimum labour force as may be required for the job and plan and execute the construction and erection according to the prescribed schedule. No extra rate will be considered for such work in monsoon.
- 57.2 During monsoon and other period, it shall be the responsibility of the CONTRACTOR to keep the construction work site free from water at his own cost.
- 58 Work on sundays and holidays:**
- 58.1 For carrying out Work on Sundays, and Holidays, the CONTRACTOR will approach the ENGINEER-IN-CHARGE or his representative at least two days in advance and obtain permission in writing. The CONTRACTOR shall observe all labour laws and other statutory rules and regulations in force. In case of any violations of such laws, rules and regulations, consequence if any, including the cost thereto shall be exclusively borne by the CONTRACTOR and the EMPLOYER shall have no liability whatsoever on this account.
- 59 General conditions for construction and erection work:**
- 59.1 The working time at the site of work is 48 hours per week. Overtime work is permitted in cases of need and the EMPLOYER will not compensate the same. Shift working at 2 or 3 shifts per day will become necessary and the CONTRACTOR should take this aspect into consideration for formulating his rates for quotation. No extra claims will be entertained by the EMPLOYER on this account. For carrying out work beyond working hours the CONTRACTOR will approach the ENGINEER-IN-CHARGE or his authorized representative and obtain his prior written permission.
- 59.2 The CONTRACTOR must arrange for the placement of workers in such a way that the delayed completion of the WORK or any part thereof for any reason whatsoever will not affect their proper employment. The EMPLOYER will not entertain any claim for idle time payment whatsoever.
- 59.3 The CONTRACTOR shall submit to the EMPLOYER/ ENGINEER-IN-CHARGE reports at regular intervals regarding the state and progress of WORK. The details and proforma of the report will mutually be agreed after the award of CONTRACT. The CONTRACTOR shall provide display boards showing progress and labour strengths at worksite, as directed by the ENGINEER-IN-CHARGE.
- 60 Alterations in specifications, design and extra works:**
- 60.1 The WORK covered under this CONTRACT having to be executed by the CONTRACTOR on a lumpsum firm price/item rate quoted by him, the EMPLOYER will not accept any proposals for changes in VALUE OF CONTRACT or extension in time on account of any such changes which may arise to the CONTRACTOR's scope of WORK as a result of detailed Engineering and thereafter during the execution of WORK. The only exception to this will be a case where the EMPLOYER requests in writing to the CONTRACTOR to upgrade the SPECIFICATIONS or the size of any major pieces of equipments, plant or machinery beyond what is normally required to meet the scope of WORK as defined in the CONTRACT DOCUMENT.
- In such cases, a change order will be initialled by the CONTRACTOR at the appropriate time for the EMPLOYER's prior approval giving the full back-up data for their review and for final settlement of any impact on price within 30 (thirty) days thereafter.
- 60.2 The ENGINEER-IN-CHARGE shall have to make any alterations in, omission from, additions to or substitutions for, the Schedule of Rates, the original specifications, drawings, designs and instructions that may appear to him to be



**ELECTRICAL WORKS (SUPPLY & ERECTION)  
FOR ALTERNATE POWER SUPPLY  
ARRANGEMENT OF VIKARMPUR GUEST HOUSE  
AT TALCHER FERTILIZERS LTD., ANGUL, ODISHA  
GENERAL CONDITIONS OF CONTRACT**

PC-183 /E/8001/S-IV

0

DOC. NO.

REV.

Page 36 of 67



necessary or advisable during the progress of the WORK and the CONTRACTOR shall be bound to carry out the such altered/ extra/ new items of WORK in accordance with any instructions which may be given to him in writing signed by the ENGINEER-IN- CHARGE, and such alterations, omissions, additions or substitutions shall not invalidate the CONTRACT and any altered, additional or substituted work which the CONTRACTOR may be directed to do in the manner above specified as part of the WORK shall be carried out by the CONTRACTOR on the same conditions in all respects on which he agreed to do the main WORK. The time of completion of WORK may be extended for the part of the particular job at the discretion of the ENGINEER-IN- CHARGE, for only such alterations, additions or substitutions of the WORK, as he may consider as just and reasonable. The rates for such additional, altered or substituted WORK under this clause shall be worked out in accordance with the following provisions:-

I. For Item Rate Contract

- a) If the rates for the additional, altered or substituted WORK are specified in the CONTRACT for the WORK, the CONTRACTOR is bound to carry on the additional, altered or substituted WORK at the same rates as are specified in the CONTRACT.
- b) If the rates for the additional, altered or substituted WORK are not specifically provided in the CONTRACT for the WORK, the rates will be derived from the rates for similar class of WORK as are specified in the CONTRACT for the WORK. The opinion of the ENGINEER-IN- CHARGE, as to whether or not the rates can be reasonably so derived from the items in this CONTRACT will be final and binding on the CONTRACTOR.
- c) If the rates for the altered, additional or substituted WORK cannot be determined in the manner specified in sub-clause(s) (a) and (b) above, then the CONTRACTOR shall, within 7 days of the date of receipt of order to carry out the WORK, inform the ENGINEER-IN-CHARGE of the rates which it is his intention to charge for such class of WORK, supported by analysis of the rate or rates claimed, and the ENGINEER-IN-CHARGE shall determine the rate or rates on the basis of the prevailing market rates, labour cost at schedule of labour rates plus 10% to cover contractor's supervision, overheads and profit and pay the CONTRACTOR accordingly. The opinion of the ENGINEER- IN-CHARGE as to current market rates of materials and the quantum of labour involved per unit of measurement will be final and binding on the CONTRACTOR.
- d) Where the item of work will be executed through nominated specialist agency as approved by the ENGINEER-IN-CHARGE, then the actual amount paid to such nominated agency supported by documentary evidence and as certified by ENGINEER-IN-CHARGE shall be considered plus 10% (ten percent) to cover all contingencies, overhead, profits to arrive at the rates.
- e) Provisions contained in the Sub-clause (a) & (d) above shall, however, not apply for the following:-





**ELECTRICAL WORKS (SUPPLY & ERECTION)  
FOR ALTERNATE POWER SUPPLY  
ARRANGEMENT OF VIKARMPUR GUEST HOUSE  
AT TALCHER FERTILIZERS LTD., ANGUL, ODISHA  
GENERAL CONDITIONS OF CONTRACT**

PC-183 /E/8001/S-IV

0

DOC. NO.

REV.

Page 37 of 67



Where the value of additions of new items together with the value of alterations, additions/ deletions or substitutions does not exceed by or is not less than plus/minus (±)25% of the VALUE OF CONTRACT. The item rates in the Schedule of Rates shall hold good for all such variations between the above mentioned limits, irrespective of any increase/decrease of quantities in the individual items of Schedule of Rates.

Where the value of addition of new items together with the value of alterations, additions/ deletions or substitutions reduces more than 25% of the contract value but is within the following limits the tenderer shall be paid compensation for decrease in the value of work, as follows:

S.No.	Range of Variation	Percentage compensation for decrease in the value of work in the respective range.
a)	Beyond (+) 25% upto & inclusive of (+) 50%	No increase and/ or decrease shall be applicable for the Schedule of Rates (The rates quoted for this increase shall be valid).
b)	Beyond (-) 25% upto & inclusive of (-) 50%	For reduction beyond 25% contractor shall be compensated by an amount equivalent to 10% of the reduction in value of the contract as awarded. For example if the actual contract value is 70% of awarded value then compensation shall be 10% of (75-70) i.e. 0.5% of awarded contract value.

**II. For Lumpsum Contracts**

CONTRACTOR shall, within 7 days of the date of receipt of order to carry out the WORK, inform the ENGINEER-IN- CHARGE of the rates which it is his intention to charge for such class of WORK, supported by analysis of the rate or rates claimed, and the ENGINEER-IN-CHARGE shall determine the rate or rates on the basis of the prevailing market rates, labour cost at schedule of labour rates plus 10% to cover contractor's supervision, overheads and profit and pay the CONTRACTOR accordingly. The opinion of the ENGINEER-IN-CHARGE as to current market rates of materials and the quantum of labour involved per unit of measurement will be final and binding on the CONTRACTOR.

**61 Drawings to be supplied by the employer**

- 61.1 The drawings attached with tender are only for the general guidance to the CONTRACTOR to enable him to visualize the type of work contemplated and scope of work involved. The CONTRACTOR will be deemed to have studied the DRAWINGS and formed an idea about the WORK involved.
- 61.2 Detailed working drawings on the basis of which actual execution of the WORK is to proceed, will be furnished from time to time during the progress of the work. The CONTRACTOR shall be deemed to have gone through the DRAWINGS supplied to him thoroughly and carefully and in conjunction with all other connected drawings and bring to the notice of the ENGINEER-IN-CHARGE discrepancies, if any, therein before actually carrying out the Work.





**ELECTRICAL WORKS (SUPPLY & ERECTION)  
FOR ALTERNATE POWER SUPPLY  
ARRANGEMENT OF VIKARMPUR GUEST HOUSE  
AT TALCHER FERTILIZERS LTD., ANGUL, ODISHA  
GENERAL CONDITIONS OF CONTRACT**

PC-183 /E/8001/S-IV

0

DOC. NO.

REV.

Page 38 of 67



- 61.3 Copies of all detailed working drawings relating to the WORK shall be kept at the CONTRACTOR's office on the site and shall be made available to the ENGINEER-IN- CHARGE at any time during the CONTRACT. The drawings and other documents issued by the EMPLOYER shall be returned to the EMPLOYER on completion of the WORK.
- 62 Drawings to be supplied by the contractor:**
- 62.1 The drawings/date which are to be furnished by the CONTRACTOR are enumerated in the special conditions of contract, and shall be furnished within the specified time.
- 62.2 Where approval/review of drawings before manufacture/ construction/fabrication has been specified, it shall be CONTRACTOR's responsibility to have these drawings prepared as per the directions of ENGINEER-IN-CHARGE and got approved before proceeding with manufacture/construction/fabrication as the case may be. Any change that may have become necessary in these drawings during the execution of the work shall have to be carried out by the CONTRACTOR to the satisfaction of ENGINEER-IN-CHARGE at no extra cost. All final drawings shall bear the certification stamp as indicated below duly signed by both the CONTRACTOR and ENGINEER-IN-CHARGE.
- "Certified true for \_\_\_\_\_ (Name of Work)
- Agreement No. \_\_\_\_\_
- Signed: \_\_\_\_\_ (CONTRACTOR) \_\_\_\_\_ (ENGINEER-IN-CHARGE)
- 62.3 The DRAWINGS submitted by the CONTRACTOR shall be reviewed by the ENGINEER-IN-CHARGE as far as practicable within 3 (Three) weeks and shall be modified by the CONTRACTOR, if any modifications and/or corrections are required by the ENGINEER-IN-CHARGE. The CONTRACTOR shall incorporate such modifications and/or corrections and submit the final drawings for approval. Any delays arising out of failure by the CONTRACTOR to rectify the drawing in good time shall not alter the Contract Completion Time.
- 62.4 As built drawings showing all corrections, adjustments etc. shall be furnished by the CONTRACTOR in six copies and one transparent for record purposed to the EMPLOYER.
- 63 Setting out works:**
- 63.1 The ENGINEER-IN-CHARGE shall furnish the CONTRACTOR with only the four corners of the Works site and a level bench mark and the CONTRACTOR shall set out the Works and shall provide an efficient staff for the purpose and shall be solely responsible for the accuracy of such setting out.
- 63.2 The CONTRACTOR shall provide, fix and be responsible for the maintenance of all stakes, templates, level marks, profiles and other similar things and shall take all necessary precautions to prevent their removal or disturbance and shall be responsible for the consequence of such removal or disturbance should the same take place and for their efficient and timely reinstatement. The CONTRACTOR shall also be responsible for the maintenance of all existing survey marks, boundary marks, distance marks and center line marks, either existing or supplied and fixed by the CONTRACTOR. The work shall be set out to the satisfaction of the ENGINEER-IN-CHARGE. The approval there of joining with the CONTRACTOR by the ENGINEER- IN-CHARGE in setting out the work, shall not relieve the CONTRACTOR of any of his responsibility.
- 63.3 Before beginning the Works, the CONTRACTOR shall at his own cost, provide all necessary reference and level posts, pegs, bamboos, flags, ranging rods, strings



**ELECTRICAL WORKS (SUPPLY & ERECTION)  
FOR ALTERNATE POWER SUPPLY  
ARRANGEMENT OF VIKARMPUR GUEST HOUSE  
AT TALCHER FERTILIZERS LTD., ANGUL, ODISHA  
GENERAL CONDITIONS OF CONTRACT**

PC-183 /E/8001/S-IV

0

DOC. NO.

REV.

Page 39 of 67



and other materials for proper layout of the works in accordance with the schemes for bearing marks acceptable to the ENGINEER-IN-CHARGE. The center, longitudinal or face lines and cross lines shall be marked by means of small masonry pillars. Each pillar shall have distinct mark at the centre to enable theodolite to be set over it. No work shall be started until all these points are checked and approved by the ENGINEER-IN-CHARGE in writing but such approval shall not relieve the CONTRACTOR of any of his responsibilities. The CONTRACTOR shall also provide all labour, material and other facilities, as necessary, for the proper checking of layout and inspection of the points during construction.

- 63.4 Pillars bearing geodetic marks located at the sites of units of WORKS under construction should be protected and fenced by the CONTRACTOR.
- 63.5 On completion of WORK, the CONTRACTOR must submit the geodetic documents according to which the WORK was carried out.
- 64 Responsibility for level and alignment:**
- 64.1 The CONTRACTOR shall be entirely and exclusively responsible for the horizontal and vertical alignment, the levels and correctness of every part of the WORK and shall rectify effectively any errors or imperfections therein, such rectifications shall be carried out by the CONTRACTOR, at his own cost, when instructions are issued to that effect by the ENGINEER- IN-CHARGE.
- 65 Materials to be supplied by contractor:**
- 65.1 The CONTRACTOR shall procure and provide within the VALUE OF CONTRACT the whole of the materials required for the construction including steels, cement and other building materials, tools, tackles, construction plant and equipment for the completion and maintenance of the WORK except the materials which will be issued by the EMPLOYER and shall make his own arrangement for procuring such materials and for the transport thereof. The EMPLOYER may give necessary recommendation to the respective authority if so desired by the CONTRACTOR but assumes no further responsibility of any nature. The EMPLOYER will insist on the procurement of materials which bear ISI stamp and/or which are supplied by reputed suppliers.
- 65.2 The CONTRACTOR shall properly store all materials either issued to him or brought by him to the SITE to prevent damages due to rain, wind, direct exposure to sun, etc. as also from theft, pilferage, etc. for proper and speedy execution of his works. The CONTRACTOR shall maintain sufficient stocks of all materials required by him.
- 65.3 No material shall be dispatched from the CONTRACTOR's stores before obtaining the approval in writing of the ENGINEER-IN-CHARGE.
- 66 Stores supplied by the employer:**
- (Clause not applicable for this Tender)*
- 66.1 If the SPECIFICATION of the WORK provides for the use of any material of special description to be supplied from the EMPLOYER's stores or it is required that the CONTRACTOR shall use certain stores to be provided by the ENGINEER-IN-CHARGE, such materials and stores, and price to be charged there for as hereinafter mentioned being so far as practicable for the convenience of the CONTRACTOR, but not so as in any way to control the meaning or effect of the CONTRACT, the CONTRACTOR shall be bound to purchase and shall be supplied such materials and stores as are from time to time required to be used by him for the purpose of the CONTRACT only. The sums due from the CONTRACTOR for the value of materials supplied by the EMPLOYER will be recovered from the running account bill on the basis of the actual consumption of materials in the works covered and for which the running account bill has been prepared. After the completion of the WORK, however, the CONTRACTOR has to account for the full quantity of materials supplied to him as per relevant clauses in this document.



**ELECTRICAL WORKS (SUPPLY & ERECTION)  
FOR ALTERNATE POWER SUPPLY  
ARRANGEMENT OF VIKARMPUR GUEST HOUSE  
AT TALCHER FERTILIZERS LTD., ANGUL, ODISHA  
GENERAL CONDITIONS OF CONTRACT**

PC-183 /E/8001/S-IV

0

DOC. NO.

REV.

Page 40 of 67



66.2 The value of the stores/materials as may be supplied to the CONTRACTOR by the EMPLOYER will be debited to the CONTRACTOR's account at the rates shown in the schedule of materials and if they are not entered in the schedule, they will be debited at cost price, which for the purpose of the CONTRACT shall include the cost of carriage and all other expenses whatsoever such as normal storage supervision charges which shall have been incurred in obtaining the same at the EMPLOYER's stores. All materials so supplied to the CONTRACTOR shall remain the absolute property of the EMPLOYER and shall not be removed on any account from the SITE of the WORK, and shall be at all times open for inspection to the ENGINEER-IN-CHARGE. Any such materials remaining unused at the time of the completion or termination of the CONTRACT shall be returned to the EMPLOYER's stores or at a place as directed by the ENGINEER-IN-CHARGE in perfectly good condition at CONTRACTOR's cost.

**67 Conditions for issue of materials:**

*(Clause not applicable for this Tender)*

- 67.1 i) Materials specified as to be issued by the EMPLOYER will be supplied to the CONTRACTOR by the EMPLOYER from his stores. It shall be responsibility of the CONTRACTOR to take delivery of the materials and arrange for its loading, transport and unloading at the SITE of WORK at his own cost. The materials shall be issued between the working hours and as per the rules of the EMPLOYER as framed from time to time.
- ii) The CONTRACTOR shall bear all incidental charges for the storage and safe custody of materials at site after these have been issued to him.
- iii) Materials specified as to be issued by the EMPLOYER shall be issued in standard sizes as obtained from the manufacturers.
- iv) The CONTRACTOR shall construct suitable Godowns at the SITE of WORK for storing the materials safe against damage by rain, dampness, fire, theft etc. He shall also employ necessary watch and ward establishment for the purpose.
- v) It shall be duty of the CONTRACTOR to inspect the materials supplied to him at the time of taking delivery and satisfy himself that they are in good condition. After the materials have been delivered by the EMPLOYER, it shall be the responsibility of the CONTRACTOR to keep them in good condition and if the materials are damaged or lost, at any time, they shall be repaired and/or replaced by him at his own cost according to the instructions of the ENGINEER-IN-CHARGE.
- vi) The EMPLOYER shall not be liable for delay in supply or non-supply of any materials which the EMPLOYER has undertaken to supply where such failure or delay is due to natural calamities, act of enemies, transport and procurement difficulties and any circumstances beyond the control of the EMPLOYER. In no case, the CONTRACTOR shall be entitled to claim any compensation or loss suffered by him on this account.
- vii) It shall be responsibility of the CONTRACTOR to arrange in time all materials required for the WORK other than those to be supplied by the EMPLOYER. If, however, in the opinion of the ENGINEER-IN-CHARGE the execution of the WORK is likely to be delayed due to the CONTRACTOR's inability to make arrangements for supply of materials which normally he has to arrange for, the ENGINEER-IN-CHARGE shall have the right at his own discretion to issue such materials, if available with the EMPLOYER or procure the



**ELECTRICAL WORKS (SUPPLY & ERECTION)  
FOR ALTERNATE POWER SUPPLY  
ARRANGEMENT OF VIKARMPUR GUEST HOUSE  
AT TALCHER FERTILIZERS LTD., ANGUL, ODISHA  
GENERAL CONDITIONS OF CONTRACT**

PC-183 /E/8001/S-IV

0

DOC. NO.

REV.

Page 41 of 67



materials from the market or as elsewhere and the CONTRACTOR will be bound to take such materials at the rates decided by the ENGINEER-IN-CHARGE. This, however, does not in any way absolve the CONTRACTOR from responsibility of making arrangements for the supply of such materials in part or in full, should such a situation occur nor shall this constitute a reason for the delay in the execution of the WORK.

- viii) None of the materials supplied to the CONTRACTOR will be utilized by the CONTRACTOR for manufacturing item which can be obtained as supplied from standard manufacturer in finished form.
- ix) The CONTRACTOR shall, if desired by the ENGINEER-IN-CHARGE, be required to execute an Indemnity Bond in the prescribed form for safe custody and accounting of all materials issued by the EMPLOYER.
- x) The CONTRACTOR shall furnish to the ENGINEER-IN-CHARGE sufficiently in advance a statement showing his requirement of the quantities of the materials to be supplied by the EMPLOYER and the time when the same will be required by him for the works, so as to enable the ENGINEER-IN-CHARGE to make necessary arrangements for procurement and supply of the material.
- xi) Account of the materials issued by the EMPLOYER shall be maintained by CONTRACTOR indicating the daily receipt, consumption and balance in hand. This account shall be maintained in a manner prescribed by the ENGINEER-IN-CHARGE along with all connected papers viz. requisitions, issues, etc., and shall be always available for inspection in the CONTRACTOR's office at SITE.
- xii) The CONTRACTOR should see that only the required quantities of materials are got issued. The CONTRACTOR shall not be entitled to cartage and incidental charges for returning the surplus materials, if any, to the stores wherefrom they were issued or to the place as directed by the ENGINEER-IN-CHARGE.
- xiii) Materials/ Equipment(s) supplied by EMPLOYER shall not be utilized for any purpose(s) than issued for.

**68 Material procured with assistance of employer/ return of surplus:**

*(Clause not applicable for this Tender)*

68.1 Notwithstanding anything contained to the contrary in any or all the clauses of this CONTRACT where any materials for the execution of the CONTRACT are procured with the assistance of the EMPLOYER either by issue from EMPLOYER's stock or purchases made under order or permits or licenses issued by Government, the CONTRACTOR shall hold the said materials as trustee for the EMPLOYER and use such materials economically and solely for the purpose of the CONTRACT and not dispose them off without the permission of the EMPLOYER and return, if required by the ENGINEER-IN-CHARGE, shall determine having due regard to the condition of the materials. The price allowed to the CONTRACTOR, however, shall not exceed the amount charged to him excluding the storage charges, if any. The decision of the ENGINEER-IN-CHARGE shall be final and conclusive in such matters. In the event of breach of the aforesaid condition, the CONTRACTOR shall, in terms of the licenses or permits and/or criminal breach of trust, be liable to compensate the EMPLOYER at double rate or any higher rate, in the event of those materials at that time having higher rate or not being available in the market, then any other rate to be determined by the ENGINEER-IN-CHARGE and his decision shall be final and conclusive.



**ELECTRICAL WORKS (SUPPLY & ERECTION)  
FOR ALTERNATE POWER SUPPLY  
ARRANGEMENT OF VIKARMPUR GUEST HOUSE  
AT TALCHER FERTILIZERS LTD., ANGUL, ODISHA  
GENERAL CONDITIONS OF CONTRACT**

PC-183 /E/8001/S-IV

0

DOC. NO.

REV.

Page 42 of 67



- 69 Materials obtained from dismantling:** 69.1 If the CONTRACTOR in the course of execution of the WORK is called upon to dismantle any part for reasons other than those stipulated in Clauses 74 and 77 hereunder, the materials obtained in the WORK of dismantling etc., will be considered as the EMPLOYER's property and will be disposed off to the best advantage of the EMPLOYER.
- 70 Articles of value found:** 70.1 All gold, silver and other minerals of any description and all precious stones, coins, treasure relics, antiquities and other similar things which shall be found in, under or upon the SITE, shall be the property of the EMPLOYER and the CONTRACTOR shall duly preserve the same to the satisfaction of the ENGINEER-IN-CHARGE and shall from time to time deliver the same to such person or persons indicated by the EMPLOYER.
- 71 Discrepancies between instructions:** 71.1 Should any discrepancy occur between the various instructions furnished to the CONTRACTOR, his agent or staff or any doubt arises as to the meaning of any such instructions or should there be any misunderstanding between the CONTRACTOR's staff and the ENGINEER-IN-CHARGE's staff, the CONTRACTOR shall refer the matter immediately in writing to the ENGINEER-IN-CHARGE whose decision thereon shall be final and conclusive and no claim for losses alleged to have been caused by such discrepancies between instructions, doubts, or misunderstanding shall in any event be admissible.
- 72 Action where no specification is issued:** 72.1 In case of any class of WORK for which there is no SPECIFICATION supplied by the EMPLOYER as mentioned in the Tender Documents such WORK shall be carried out in accordance with Indian Standard Specifications and if the Indian Standard Specifications do not cover the same, the WORK should be carried out as per standard Engineering Practice subject to the approval of the ENGINEER-IN-CHARGE.
- 73 Inspection of works:** 73.1 The ENGINEER-IN-CHARGE will have full power and authority to inspect the WORK at any time wherever in progress either on the SITE or at the CONTRACTOR's premises/workshops wherever situated, premises/ workshops of any person, firm or corporation where WORK in connection with the CONTRACT may be in hand or where materials are being or are to be supplied, and the CONTRACTOR shall afford or procure for the ENGINEER-IN-CHARGE every facility and assistance to carry out such inspection. The CONTRACTOR shall, at all time during the usual working hours and at all other time at which reasonable notice of the intention of the ENGINEER-IN-CHARGE or his representative to visit the WORK shall have been given to the CONTRACTOR, either himself be present or receive orders and instructions, or have a responsible agent duly accredited in writing, present for the purpose. Orders given to the CONTRACTOR's agent shall be considered to have the same force as if they had been given to the CONTRACTOR himself. The CONTRACTOR shall give not less than seven days notice in writing to the ENGINEER-IN-CHARGE before covering up or otherwise placing beyond reach of inspection and measurement of any work in order that the same may be inspected and measured. In the event of breach of above the same shall be uncovered at CONTRACTOR's expense for carrying out such measurement or inspection.
- 73.2 No material shall be dispatched from the CONTRACTOR's stores before obtaining the approval in writing of the Engineer-in-Charge.
- The CONTRACTOR is to provide at all time during the progress of the WORK and the maintenance period, proper means of access with ladders, gangways etc. and the necessary attendance to move and adopt as directed for inspection or measurements of the WORK by the ENGINEER-IN-CHARGE.





**ELECTRICAL WORKS (SUPPLY & ERECTION)  
FOR ALTERNATE POWER SUPPLY  
ARRANGEMENT OF VIKARMPUR GUEST HOUSE  
AT TALCHER FERTILIZERS LTD., ANGUL, ODISHA  
GENERAL CONDITIONS OF CONTRACT**

PC-183 /E/8001/S-IV

0

DOC. NO.

REV.

Page 43 of 67



- 73.3 The CONTRACTOR shall make available to the ENGINEER-IN- CHARGE free of cost all necessary instruments and assistance in checking or setting out of WORK and in the checking of any WORK made by the CONTRACTOR for the purpose of setting out and taking measurements of WORK.
- 74 Tests for quality of work:**
- 74.1 All workmanship shall be of the respective kinds described in the CONTRACT DOCUMENTS and in accordance with the instructions of the ENGINEER-IN-CHARGE and shall be subjected from time to time to such test at CONTRACTOR's cost as the ENGINEER-IN-CHARGE may direct at the place of manufacture or fabrication or on the site or at all or any such places. The CONTRACTOR shall provide assistance, instruments, labour and materials as are normally required for examining, measuring and testing any workmanship as may be selected and required by the ENGINEER-IN-CHARGE.
- 74.2 All the tests that will be necessary in connection with the execution of the WORK as decided by the ENGINEER- IN-CHARGE shall be carried out at the field testing laboratory of the EMPLOYER by paying the charges as decided by the EMPLOYER from time to time. In case of non- availability of testing facility with the EMPLOYER, the required test shall be carried out at the cost of CONTRACTOR at Government or any other testing laboratory as directed by ENGINEER-IN-CHARGE.
- 74.3 If any tests are required to be carried out in conjunction with the WORK or materials or workmanship not supplied by the CONTRACTOR, such tests shall be carried out by the CONTRACTOR as per instructions of ENGINEER-IN-CHARGE and cost of such tests shall be reimbursed by the EMPLOYER.
- 75 Samples for approval:**
- 75.1 The CONTRACTOR shall furnish to the ENGINEER-IN-CHARGE for approval, when requested or if required by the specifications, adequate samples of all materials and finished to be used in the WORK. Such samples shall be submitted before the WORK is commenced and in ample time to permit tests and examinations thereof. All materials furnished and finishes applied in actual WORK shall be fully equal to the approved samples.
- 76 Action and compensation in case of bad work:**
- 76.1 If it shall appear to the ENGINEER-IN-CHARGE that any work has been executed with unsound, imperfect or unskilled workmanship, or with materials of any inferior description, or that any materials or articles provided by the CONTRACTOR for the execution of the WORK are unsound, or of a quality inferior to that contracted for, or otherwise not in accordance with the CONTRACT, the CONTRACTOR shall on demand in writing from the ENGINEER-IN-CHARGE or his authorized representative specifying the WORK, materials or articles complained of notwithstanding that the same may have been inadvertently passed, certified and paid for, forthwith rectify or remove and reconstruct the WORK so specified and provide other proper and suitable materials or articles at his own cost and in the event of failure to do so within the period specified by the ENGINEER-IN-CHARGE in his demand aforesaid, the CONTRACTOR shall be liable to pay compensation at the rate of 1% (One percent) of the estimated cost of the whole WORK, for every week limited to a maximum of 10% (ten percent) of the value of the whole WORK, while his failure to do so shall continue and in the case of any such failure the ENGINEER-IN-CHARGE may on expiry of notice period rectify or remove and re-execute the WORK or remove and replaced with others, the materials or articles complained of to as the case may be at the risk and expense in all respects of the CONTRACTOR. The decision of the Engineering-in-charge as to any question arising under this clause shall be final and conclusive.



**ELECTRICAL WORKS (SUPPLY & ERECTION)  
FOR ALTERNATE POWER SUPPLY  
ARRANGEMENT OF VIKARMPUR GUEST HOUSE  
AT TALCHER FERTILIZERS LTD., ANGUL, ODISHA  
GENERAL CONDITIONS OF CONTRACT**

PC-183 /E/8001/S-IV

0

DOC. NO.

REV.

Page 44 of 67



- 77 **Suspension of works:** 77.1 i) Subject to the provisions of sub-para (ii) of this clause, the CONTRACTOR shall, if ordered in writing by the ENGINEER-IN-CHARGE, or his representative, temporarily suspend the WORKS or any part thereof for such written order, proceed with the WORK therein ordered to be suspended until, he shall have received a written order to proceed therewith. The CONTRACTOR shall not be entitled to claim compensation for any loss or damage sustained by him by reason of temporary suspension of the WORKS aforesaid. An extension of time for completion, corresponding with the delay caused by any such suspension of the WORKS as aforesaid will be granted to the CONTRACTOR should he apply for the same provided that the suspension was not consequent to any default or failure on the part of the CONTRACTOR.
- ii) In case of suspensions of entire WORK, ordered in writing by ENGINEER-IN-CHARGE, for a period of more than two months, the CONTRACTOR shall have the option to terminate the CONTRACT.
- 78 **Employer may do part of work:** 78.1 Upon failure of the CONTRACTOR to comply with any instructions given in accordance with the provisions of this CONTRACT the EMPLOYER has the alternative right, instead of assuming charge of entire WORK, to place additional labour force, tools, equipments and materials on such parts of the WORK, as the EMPLOYER may designate or also engage another CONTRACTOR to carry out the WORK. In such cases, the EMPLOYER shall deduct from the amount which otherwise might become due to the CONTRACTOR, the cost of such work and material with ten percent (10%) added to cover all departmental charges and should the total amount thereof exceed the amount due to the CONTRACTOR, the CONTRACTOR shall pay the difference to the EMPLOYER.
- 79 **Possession prior to completion:** 79.1 The ENGINEER-IN-CHARGE shall have the right to take possession of or use any completed or partially completed WORK or part of the WORK. Such possession or use shall not be deemed to be an acceptance of any work completed in accordance with the CONTRACT agreement. If such prior possession or use by the ENGINEER-IN-CHARGE delays the progress of WORK, equitable adjustment in the time of completion will be made and the CONTRACT agreement shall be deemed to be modified accordingly.
- 80 **(Defects liability period) twelve months period of liability from the date of issue of completion certificate:** 80.1 The CONTRACTOR shall guarantee the installation/WORK for a period of 12 months from the date of completion of WORK as certified by the ENGINEER-IN-CHARGE which is indicated in the Completion Certificate. Any damage or defect that may arise or lie undiscovered at the time of issue of Completion Certificate, connected in any way with the equipment or materials supplied by him or in the workmanship, shall be rectified or replaced by the CONTRACTOR at his own expense as deemed necessary by the ENGINEER-IN-CHARGE or in default, the ENGINEER-IN-CHARGE may carry out such works by other work and deduct actual cost incurred towards labour, supervision and materials consumables or otherwise plus 100% towards overheads (of which the certificate of ENGINEER-IN-CHARGE shall be final) from any sums that may then be or at any time thereafter, become due to the CONTRACTOR or from his Contract Performance Security, or the proceeds of sale thereof or a sufficient part on thereof.
- 80.2 If the CONTRACTOR feels that any variation in WORK or in quality of materials or proportions would be beneficial or necessary to fulfil the guarantees called for, he shall bring this to the notice of the ENGINEER-IN-CHARGE in writing.
- If during the period of liability any portion of the WORK/equipment, is found





**ELECTRICAL WORKS (SUPPLY & ERECTION)  
FOR ALTERNATE POWER SUPPLY  
ARRANGEMENT OF VIKARMPUR GUEST HOUSE  
AT TALCHER FERTILIZERS LTD., ANGUL, ODISHA  
GENERAL CONDITIONS OF CONTRACT**

PC-183 /E/8001/S-IV

0

DOC. NO.

REV.

Page 45 of 67



defective and is rectified/ replaced, the period of liability for such equipment/ portion of WORK shall be operative from the date such rectification/ replacement are carried out and Contract Performance Guarantee shall be furnished separately for the extended period of liability for that portion of WORK/ equipment only. Notwithstanding the above provisions the supplier's, guarantees/warrantees for the replaced equipment shall also be passed on to the EMPLOYER.

80.3 LIMITATION OF LIABILITY

Notwithstanding anything contrary contained herein, the aggregate total liability of CONTRACTOR under the Agreement or otherwise shall be limited to 100% of Agreement / Contract Value. However, neither party shall be liable to the other party for any indirect and consequential damages, loss of profits or loss of production.

**81 Care of works:**

81.0 From the commencement to completion of the WORK, the CONTRACTOR shall take full responsibility for the care for all works including all temporary works and in case any damages, loss or injury shall happen to the WORK or to any part thereof or to any temporary works from any cause whatsoever, shall at his own cost repair and make good the same so that at completion the WORK shall be in good order and in conformity in every respects with the requirement of the CONTRACT and the ENGINEER-IN-CHARGE's instructions.

81.1 DEFECTS PRIOR TO TAKING OVER:

If at any time, before the WORK is taken over, the ENGINEER-IN-CHARGE shall:

- a) Decide that any works done or materials used by the CONTRACTOR or by any SUB-CONTRACTOR is defective or not in accordance with the CONTRACT, or that the works or any portion thereof are defective, or do not fulfill the requirements of CONTRACT (all such matters being hereinafter, called 'Defects' in this clause), and
- b) As soon as reasonably practicable, gives to the CONTRACTOR notice in writing of the said decision, specifying particulars of the defects alleged to exist or to have occurred, then the CONTRACTOR shall at his own expenses and with all speed make good the defects so specified.

In case CONTRACTOR shall fail to do so, the EMPLOYER may take, at the cost of the CONTRACTOR, such steps as may in all circumstances, be reasonable to make good such defects. The expenditure so incurred by the EMPLOYER will be recovered from the amount due to the CONTRACTOR. The decision of the ENGINEER-IN-CHARGE with regard to the amount to be recovered from the CONTRACTOR will be final and binding on the CONTRACTOR. As soon as the WORK has been completed in accordance with the CONTRACT (except in minor respects that do not affect their use for the purpose for which they are intended and except for maintenance there of provided in clause 80.1 of General Conditions of Contract) and have passed the tests on completion, the ENGINEER-IN-CHARGE shall issue a certificate (hereinafter called Completion Certificate) in which he shall certify the date on which the WORK have been so completed and have passed the said tests and the EMPLOYER shall be deemed to have taken over the WORK on the date so certified. If the WORK has been divided into various groups in the CONTRACT, the EMPLOYER shall be entitled to take over any group or groups before the other or others and there upon the ENGINEER-IN-CHARGE shall issue a Completion Certificate which will, however, be for such group or groups so taken over only. In such an event if the group /section/ part so taken over is related, to the integrated system of the work,



**ELECTRICAL WORKS (SUPPLY & ERECTION)  
FOR ALTERNATE POWER SUPPLY  
ARRANGEMENT OF VIKARMPUR GUEST HOUSE  
AT TALCHER FERTILIZERS LTD., ANGUL, ODISHA  
GENERAL CONDITIONS OF CONTRACT**

PC-183 /E/8001/S-IV

0

DOC. NO.

REV.

Page 46 of 67



notwithstanding date of grant of Completion Certificate for group/ section/ part. The period of liability in respect of such group/ section/ part shall extend 12 (twelve) months from the date of completion of WORK.

81.2 DEFECTS AFTER TAKING OVER:

In order that the CONTRACTOR could obtain a COMPLETION CERTIFICATE he shall make good, with all possible speed, any defect arising from the defective materials supplied by the CONTRACTOR or workmanship or any act or omission of the CONTRACT or that may have been noticed or developed, after the works or groups of the works has been taken over, the period allowed for carrying out such WORK will be normally one month. If any defect be not remedied within a reasonable time, the EMPLOYER may proceed to do the WORK at CONTRACTOR's risk and expense and deduct from the final bill such amount as may be decided by the EMPLOYER.

If by reason of any default on the part of the CONTRACTOR a COMPLETION CERTIFICATE has not been issued in respect of any portion of the WORK within one month after the date fixed by the CONTRACT for the completion of the WORK, the EMPLOYER shall be at liberty to use the WORK or any portion thereof in respect of which a completion certificate has not been issued, provided that the WORK or the portion thereof so used as aforesaid shall be afforded reasonable opportunity for completing these works for the issue of Completion Certificate.

- |   |      |  |
|---|------|--|
| <b>82 Guarantee/transfer of guarantee:</b>                                    | 82.1 | For works like water-proofing, acid and alkali resisting materials, pre-construction soil treatment against termite or any other specialized works etc. the CONTRACTOR shall invariably engage SUB-CONTRACTORS who are specialists in the field and firms of repute and such a SUB-CONTRACTOR shall furnish guarantees for their workmanship to the EMPLOYER, through the CONTRACTOR. In case such a SUB-CONTRACTOR/ firm is not prepared to furnish a guarantee to the EMPLOYER, the CONTRACTOR shall give that guarantee to the EMPLOYER directly.   |
| <b>83 Training of employer's personnel:</b><br><u>(Clause not applicable)</u> | 83.1 | The CONTRACTOR undertakes to provide training to Engineering personnel selected and sent by the EMPLOYER at the works of the CONTRACTOR without any cost to the EMPLOYER. The period and the nature of training for the individual personnel shall be agreed upon mutually between the CONTRACTOR and the EMPLOYER. These engineering personnel shall be given special training at the shops, where the equipment will be manufactured and/ or in their collaborator's works and where possible, in any other plant where equipment manufactured by the CONTRACTOR or his collaborators is under installation or test to enable those personnel to become familiar with the equipment being furnished by the CONTRACTOR. EMPLOYER shall bear only the to and fro fare of the said engineering personnel.   |
| <b>84 Replacement of defective parts and materials:</b>                       | 84.1 | If during the progress of the WORK, EMPLOYER shall decide and inform in writing to the CONTRACTOR, that the CONTRACTOR has manufactured any plant or part of the plant unsound or imperfect or has furnished plant inferior to the quality specified, the CONTRACTOR on receiving details of such defects or deficiencies shall at his own expenses within 7 (seven) days of his receiving the notice, or otherwise within such time as may be reasonably necessary for making it good, proceed to alter, re-construct or remove such work and furnish fresh equipments up to the standards of the specifications. In case the CONTRACTOR fails to do so, EMPLOYER may on giving the CONTRACTOR 7 (seven) day's notice in writing of his intentions to do so, proceed to remove the portion of the WORK so complained of and at the cost of CONTRACTOR's, perform all such |



**ELECTRICAL WORKS (SUPPLY & ERECTION)  
FOR ALTERNATE POWER SUPPLY  
ARRANGEMENT OF VIKARMPUR GUEST HOUSE  
AT TALCHER FERTILIZERS LTD., ANGUL, ODISHA  
GENERAL CONDITIONS OF CONTRACT**

PC-183 /E/8001/S-IV

0

DOC. NO.

REV.

Page 47 of 67



works or furnish all such equipments provided that nothing in the clause shall be deemed to deprive the EMPLOYER of or affect any rights under the CONTRACT, the EMPLOYER may otherwise have in respect of such defects and deficiencies.

84.2 The CONTRACTOR's full and extreme liability under this clause shall be satisfied by the payments to the EMPLOYER of the extra cost, of such replacements procured including erection/installation as provided for in the CONTRACT; such extra cost being the ascertained difference between the price paid by the EMPLOYER for such replacements and the CONTRACT price portion for such defective plants and repayments of any sum paid by the EMPLOYER to the CONTRACTOR in respect of such defective plant. Should the EMPLOYER not so replace the defective plant the CONTRACTOR's extreme liability under this clause shall be limited to the repayment of all such sums paid by the EMPLOYER under the CONTRACT for such defective plant.

**85 Indemnity**

85.1 If any action is brought before a Court, Tribunal or any other Authority against the Employer or an officer or agent of the EMPLOYER, for the failure, omission or neglect on the part of the CONTRACTOR to perform any acts, matters, covenants or things under the CONTRACT, or damage or injury caused by the alleged omission or negligence on the part of the CONTRACTOR, his agents, representatives or his SUB- CONTRACTOR's, or in connection with any claim based on lawful demands of SUB-CONTRACTOR's workmen suppliers or employees, the CONTRACTOR, shall in such cases indemnify and keep the EMPLOYER and/or their representatives harmless from all losses, damages, expenses or decrees arising out of such action.

**86 Construction aids, equipments, tools & tackles:**

86.1 CONTRACTOR shall be solely responsible for making available for executing the WORK, all requisite CONSTRUCTION EQUIPMENTS, Special Aids, Barges, Cranes and the like, all Tools, Tackles and Testing Equipment and Appliances, including imports of such equipment etc. as required. In case of import of the same the rates applicable for levying of Custom Duty on such Equipment, Tools, & Tackles and the duty drawback applicable thereon shall be ascertained by the CONTRACTOR from the concerned authorities of Government of India. It shall be clearly understood that EMPLOYER shall not in any way be responsible for arranging to obtain Custom Clearance and/or payment of any duties and/or duty draw backs etc. for such equipments so imported by the CONTRACTOR and the CONTRACTOR shall be fully responsible for all taxes, duties and documentation with regard to the same. Tenderer in his own interest may contact, for any clarifications in the matter, concerned agencies/Dept./Ministries of Govt. of India. All clarifications so obtained and interpretations thereof shall be solely the responsibility of the CONTRACTOR.

**SECTION-VI Certificates and Payments**

**87 Schedule of rates and payments:**

87.1 i) CONTRACTOR'S REMUNERATION:

The price to be paid by the EMPLOYER to CONTRACTOR for the whole of the WORK to be done and for the performance of all the obligations undertaken by the CONTRACTOR under the CONTRACT DOCUMENTS shall be ascertained by the application of the respective Schedule of Rates (the inclusive nature of which is more particularly defined by way of application but not of limitation, with the succeeding sub-clause of this clause) and payment to be made accordingly for the WORK actually executed and approved by the ENGINEER-IN-CHARGE. The sum so ascertained shall (excepting only as and to the extent expressly provided herein) constitute the sole and inclusive



**ELECTRICAL WORKS (SUPPLY & ERECTION)  
FOR ALTERNATE POWER SUPPLY  
ARRANGEMENT OF VIKARMPUR GUEST HOUSE  
AT TALCHER FERTILIZERS LTD., ANGUL, ODISHA  
GENERAL CONDITIONS OF CONTRACT**

PC-183 /E/8001/S-IV

0

DOC. NO.

REV.

Page 48 of 67



remuneration of the CONTRACTOR under the CONTRACT and no further or other payment whatsoever shall be or become due or payable to the CONTRACTOR under the CONTRACT.

ii) SCHEDULE OF RATES TO BE INCLUSIVE:

The prices/rates quoted by the CONTRACTOR shall remain firm till the issue of FINAL CERTIFICATE and shall not be subject to escalation. Schedule of Rates shall be deemed to include and cover all costs, expenses and liabilities of every description and all risks of every kind to be taken in executing, completing and handing over the WORK to the EMPLOYER by the CONTRACTOR. The CONTRACTOR shall be deemed to have known the nature, scope, magnitude and the extent of the WORK and materials required though the CONTRACT DOCUMENT may not fully and precisely furnish them. Tenderer's shall make such provision in the Schedule of Rates as he may consider necessary to cover the cost of such items of WORK and materials as may be reasonable and necessary to complete the WORK. The opinion of the ENGINEER-IN-CHARGE as to the items of WORK which are necessary and reasonable for COMPLETION OF WORK shall be final and binding on the CONTRACTOR, although the same may not be shown on or described specifically in CONTRACT DOCUMENTS.

Generality of this present provision shall not be deemed to cut down or limit in any way because in certain cases it may and in other cases it may not be expressly stated that the CONTRACTOR shall do or perform a work or supply articles or perform services at his own cost or without addition of payment or without extra charge or words to the same effect or that it may be stated or not stated that the same are included in and covered by the Schedule of Rates.

iii) SCHEDULE OF RATES TO COVER CONSTRUCTION EQUIPMENTS, MATERIALS, LABOUR ETC.:

Without in any way limiting the provisions of the preceding sub-clause the Schedule of Rates shall be deemed to include and cover the cost of all construction equipment, temporary WORK (except as provided for herein), pumps, materials, labour, insurance, fuel, consumables, stores and appliances to be supplied by the CONTRACTOR and all other matters in connection with each item in the Schedule of Rates and the execution of the WORK or any portion thereof finished, complete in every respect and maintained as shown or described in the CONTRACT DOCUMENTS or as may be ordered in writing during the continuance of the CONTRACT.

iv) SCHEDULE OF RATES TO COVER ROYALTIES, RENTS AND CLAIMS:

The Schedule of Rates (i.e., VALUE OF CONTRACT) shall be deemed to include and cover the cost of all royalties and fees for the articles and processes, protected by letters, patent or otherwise incorporated in or used in connection with the WORK, also all royalties, rents and other payments in connection with obtaining materials of whatsoever kind for the WORK and shall include an indemnity to the EMPLOYER which the CONTRACTOR hereby gives against all actions, proceedings, claims, damages, costs and expenses arising from the incorporation in or use on the WORK of any such articles, processes or materials, octroi or other municipal or local Board Charges, if levied on materials,



**ELECTRICAL WORKS (SUPPLY & ERECTION)  
FOR ALTERNATE POWER SUPPLY  
ARRANGEMENT OF VIKARMPUR GUEST HOUSE  
AT TALCHER FERTILIZERS LTD., ANGUL, ODISHA  
GENERAL CONDITIONS OF CONTRACT**

PC-183 /E/8001/S-IV

0

DOC. NO.

REV.

Page 49 of 67



equipment or machineries to be brought to site for use on WORK shall be borne by the CONTRACTOR.

v) SCHEDULE OF RATES TO COVER TAXES AND DUTIES:

No exemption or reduction of Customs Duties, Excise Duties, Sales Tax, Sales Tax on works Contract quay or any port dues, transport charges, stamp duties or Central or State Government or local Body or Municipal Taxes or duties, taxes or charges (from or of any other body), whatsoever, will be granted or obtained, all of which expenses shall be deemed to be included in and covered by the Schedule or Rates. The CONTRACTOR shall also obtain and pay for all permits or other privileges necessary to complete the WORK.

vi) SCHEDULE OF RATES TO COVER RISKS OF DELAY:

The Schedule of Rates shall be deemed to include and cover the risk of all possibilities of delay and interference with the CONTRACTOR's conduct of WORK which occur from any causes including orders of the EMPLOYER in the exercise of his power and on account of extension of time granted due to various reasons and for all other possible or probable causes of delay.

vii) SCHEDULE OF RATES CANNOT BE ALTERED:

For WORK under unit rate basis, no alteration will be allowed in the Schedule of Rates by reason of works or any part of them being modified, altered, extended, diminished or committed. The Schedule of Rates are fully inclusive of rates which have been fixed by the CONTRACTOR and agreed to by the EMPLOYER and cannot be altered.

For lumpsum CONTRACTS, the payment will be made according to the WORK actually carried out, for which purpose an item wise, or work wise Schedule of Rates shall be furnished, suitable for evaluating the value of WORK done and preparing running account bill. Payment for any additional work which is not covered in the Schedule of Rates, shall only be released on issuance of change order.

**88 Procedure for measurement and billing of work in progress:**

88.1 BILLING PROCEDURE:

Following procedures shall be adopted for billing of works executed by the CONTRACTOR.

88.1.1 All measurements shall be recorded in sixuplicate on standard measurement sheets supplied by EMPLOYER and submitted to EMPLOYER/CONSULTANT for scrutiny and passing.

88.1.2 EMPLOYER/CONSULTANT shall scrutinize and check the measurements recorded on the sheets and shall certify correctness of the same on the measurement sheets.

88.1.3 ENGINEER-IN-CHARGE shall pass the bills after carrying out the comprehensive checks in accordance with the terms and conditions of the CONTRACTS, within 7 days of submission of the bills, complete in all respects and send the same to the Employer to effect payment to the CONTRACTOR.



**ELECTRICAL WORKS (SUPPLY & ERECTION)  
FOR ALTERNATE POWER SUPPLY  
ARRANGEMENT OF VIKARMPUR GUEST HOUSE  
AT TALCHER FERTILIZERS LTD., ANGUL, ODISHA  
GENERAL CONDITIONS OF CONTRACT**

PC-183 /E/8001/S-IV

0

DOC. NO.

REV.

Page 50 of 67



- 88.1.4 TFL shall make all Endeavour to make payments of undisputed amount of the bills submitted based on the joint measurements within 15 (Fifteen) days from the date of certification by the Engineer-in-Charge.
- 88.1.5 Measurements shall be recorded as per the methods of measurement spelt out in EMPLOYER/CONSULTANT SPECIFICATIONS / CONTRACT DOCUMENT. EMPLOYER/CONSULTANT shall be fully responsible for checking the measurements quantitatively and qualitatively as recorded in the Measurement Books/ Bills.
- 88.1.6 While preparing the final bills overall measurements will not be taken again. Only volume of work executed since the last measured bill along with summary of final measurements will be considered for the final bill. However, a detailed check shall be made as to missing measurements and in case there are any missing items or measurements the same shall be recorded.
- 88.2 SECURED ADVANCE ON MATERIAL:  
Unless otherwise provided elsewhere in the tender, no 'Secured Advance' on security of materials brought to site for execution of contracted items(s) shall be paid to the Contractor whatsoever.
- 88.3 DISPUTE IN MODE OF MEASUREMENT:  
In case of any dispute as to the mode of measurement not covered by the CONTRACT to be adopted for any item of WORK, mode of measurement as per latest Indian Standard Specifications shall be followed.
- 88.4 ROUNDING OF AMOUNTS:  
In calculating the amount of each item due to the CONTRACTOR in every certificate prepared for payment, sum of less than 50 paise shall be omitted and the total amount on each certificate shall be rounded off to the nearest rupees, i.e., sum of less than 50 paise shall be omitted and sums of 50 paise and more upto one rupee shall be reckoned as one rupee.
- 89 Lumpsum in tender:** 89.1 The payment against any Lumpsum item shall be made only on completion of that item as per the provision of the CONTRACT after certification by ENGINEER-IN-CHARGE.
- 90 Running account payments to be regarded as advance:** 90.1 All running account payments shall be regarded as payment by way of advance against the final payment only and not as payments for WORK actually done and completed and shall not preclude the requiring of bad, unsound and imperfect or unskilled work to be removed and taken away and reconstructed or re-erected or be considered as an admission of the due performance of the CONTRACT, or any part thereof, in this respect, or of the accruing of any claim by the CONTRACTOR, nor shall it conclude, determine or affect in any way the powers of the EMPLOYER under these conditions or any of them as to the final settlement and adjustment of the accounts or otherwise, or in any other way vary or affect the CONTRACT. The final bill shall be submitted by the CONTRACTOR within one month of the date of physical completion of the WORK, otherwise, the ENGINEER-IN-CHARGE's certificate of the measurement and of total amount payable for the WORK accordingly shall be final and binding on all parties
- 91 Notice of claims for additional payments:** 91.1 Should the CONTRACTOR consider that he is entitled to any extra payment for any extra/additional WORKS or MATERIAL change in original SPECIFICATIONS carried out by him in respect of WORK he shall forthwith





**ELECTRICAL WORKS (SUPPLY & ERECTION)  
FOR ALTERNATE POWER SUPPLY  
ARRANGEMENT OF VIKARMPUR GUEST HOUSE  
AT TALCHER FERTILIZERS LTD., ANGUL, ODISHA  
GENERAL CONDITIONS OF CONTRACT**

PC-183 /E/8001/S-IV

0

DOC. NO.

REV.

Page 51 of 67



give notice in writing to the ENGINEER-IN-CHARGE that he claims extra payment. Such notice shall be given to the ENGINEER-IN-CHARGE upon which CONTRACTOR bases such claims and such notice shall contain full particulars of the nature of such claim with full details of amount claimed. Irrespective of any provision in the CONTRACT to the contrary, the CONTRACTOR must intimate his intention to lodge claim on the EMPLOYER within 10 (ten) days of the commencement of happening of the event and quantify the claim within 30 (thirty) days, failing which the CONTRACTOR will lose his right to claim any compensation/reimbursement/damages etc. or refer the matter to arbitration. Failure on the part of CONTRACTOR to put forward any claim without the necessary particulars as above within the time above specified shall be an absolute waiver thereof. No omission by EMPLOYER to reject any such claim and no delay in dealing therewith shall be waiver by EMPLOYER of any of this rights in respect thereof.

91.2 ENGINEER-IN-CHARGE shall review such claims within a reasonably period of time and cause to discharge these in a manner considered appropriate after due deliberations thereon. However, CONTRACTOR shall be obliged to carry on with the WORK during the period in which his claims are under consideration by the EMPLOYER, irrespective of the outcome of such claims, where additional payments for WORKS considered extra are justifiable in accordance with the CONTRACT provisions, EMPLOYER shall arrange to release the same in the same manner as for normal WORK payments. Such of the extra works so admitted by EMPLOYER shall be governed by all the terms, conditions, stipulations and specifications as are applicable for the CONTRACT. The rates for extra works shall generally be the unit rates provided for in the CONTRACT. In the event unit rates for extra works so executed are not available as per CONTRACT, payments may either be released on day work basis for which daily/hourly rates for workmen and hourly rates for equipment rental shall apply, or on the unit rate for WORK executed shall be derived by interpolation/extrapolation of unit rates already existing in the CONTRACT. In all the matters pertaining to applicability of rate and admittance of otherwise of an extra work claim of CONTRACTOR the decision of ENGINEER-IN-CHARGE shall be final and binding.

**92 Payment of contractor's bill:**

92.1 No payment shall be made for works estimated to cost less than Rs.10,000/- till the whole of the work shall have been completed and a certificate of completion given. But in case of works estimated to cost more than Rs.10,000/-, that CONTRACTOR on submitting the bill thereof be entitled to receive a monthly payment proportionate to the part thereof approved and passed by the ENGINEER-IN-CHARGE, whose certificate of such approval and passing of the sum so payable shall be final and conclusive against the CONTRACTOR. This payment will be made after making necessary corrections/deductions as stipulated elsewhere in the CONTRACT DOCUMENT for materials, Contract Performance Security, taxes etc.

92.2 Payment due to the CONTRACTOR shall be made by the EMPLOYER by Account Payee cheque forwarding the same to registered office or the notified office of the CONTRACTOR. In no case will EMPLOYER be responsible if the cheque is mislaid or misappropriated by unauthorized person/persons. In all cases, the CONTRACTOR shall present his bill duly pre-receipted on proper revenue stamp payment shall be made in Indian Currency.

92.3 In general payment of final bill shall be made to CONTRACTOR within 60 days of the submission of bill on joint measurements, after completion of all the obligations under the CONTRACT.





**ELECTRICAL WORKS (SUPPLY & ERECTION)  
FOR ALTERNATE POWER SUPPLY  
ARRANGEMENT OF VIKARMPUR GUEST HOUSE  
AT TALCHER FERTILIZERS LTD., ANGUL, ODISHA  
GENERAL CONDITIONS OF CONTRACT**

PC-183 /E/8001/S-IV

0

DOC. NO.

REV.

Page 52 of 67



- 93 Receipt for payment:** 93.1 Receipt for payment made on account of work when executed by a firm, must be signed by a person holding due power of attorney in this respect on behalf of the CONTRACTOR, except when the CONTRACTOR's are described in their tender as a limited company in which case the receipts must be signed in the name of the company by one of its principal officers or by some other person having authority to give effectual receipt for the company.
- 94 Completion certificate:** 94.1 APPLICATION FOR COMPLETION CERTIFICATE:  
When the CONTRACTOR fulfils his obligation under Clause 81.1 he shall be eligible to apply for COMPLETION CERTIFICATE.  
The ENGINEER-IN-CHARGE shall normally issue to the CONTRACTOR the COMPLETION CERTIFICATE within one month after receiving any application therefore from the CONTRACTOR after verifying from the completion documents and satisfying himself that the WORK has been completed in accordance with and as set out in the construction and erection drawings, and the CONTRACT DOCUMENTS.  
The CONTRACTOR, after obtaining the COMPLETION CERTIFICATE, is eligible to present the final bill for the WORK executed by him under the terms of CONTRACT.
- 94.2 COMPLETION CERTIFICATE:  
Within one month of the completion of the WORK in all respects, the CONTRACTOR shall be furnished with a certificate by the ENGINEER-IN-CHARGE of such completion, but no certificate shall be given nor shall the WORK be deemed to have been executed until all scaffolding, surplus materials and rubbish is cleared off the SITE completely nor until the WORK shall have been measured by the ENGINEER-IN-CHARGE whose measurement shall be binding and conclusive. The WORKS will not be considered as complete and taken over by the EMPLOYER, until all the temporary works, labour and staff colonies are cleared to the satisfaction of the ENGINEER-IN-CHARGE.  
If the CONTRACTOR fails to comply with the requirements of this clause on or before the date fixed for the completion of the WORK, the ENGINEER-IN-CHARGE may at the expense of the CONTRACTOR remove such scaffolding, surplus materials and rubbish and dispose off the same as he thinks fit and clean off such dirt as aforesaid, and the CONTRACTOR shall forthwith pay the amount of all expenses so incurred and shall have no claim in respect of any such scaffolding or surplus materials as aforesaid except for any sum actually realized by the sale thereof.
- 94.3 COMPLETION CERTIFICATE DOCUMENTS:  
For the purpose of Clause 94.0 the following documents will be deemed to form the completion documents:  
i) The technical documents according to which the WORK was carried out.  
ii) Six (6) sets of construction drawings showing therein the modification and correction made during the course of execution and signed by the ENGINEER-IN-CHARGE.  
iii) COMPLETION CERTIFICATE for 'embedded' and 'covered' up



**ELECTRICAL WORKS (SUPPLY & ERECTION)  
FOR ALTERNATE POWER SUPPLY  
ARRANGEMENT OF VIKARMPUR GUEST HOUSE  
AT TALCHER FERTILIZERS LTD., ANGUL, ODISHA  
GENERAL CONDITIONS OF CONTRACT**

PC-183 /E/8001/S-IV

0

DOC. NO.

REV.

Page 53 of 67



work.

iv) Certificates of final levels as set out for various works.

v) Certificates of tests performed for various WORKS.

vi) Material appropriation, Statement for the materials issued by the EMPLOYER for the WORK and list of surplus materials returned to the EMPLOYER's store duly supported by necessary documents.

**95 Final decision and final certificate:**

95.1

Upon expiry of the period of liability and subject to the ENGINEER-IN-CHARGE being satisfied that the WORKS have been duly maintained by the CONTRACTOR during monsoon or such period as hereinbefore provided in Clause 80 & 81 and that the CONTRACTOR has in all respect duly made-up any subsidence and performed all his obligations under the CONTRACT, the ENGINEER-IN-CHARGE shall (without prejudice to the rights of the EMPLOYER to retain the provisions of relevant Clause hereof) otherwise give a certificate herein referred to as the FINAL CERTIFICATE to that effect and the CONTRACTOR shall not be considered to have fulfilled the whole of his obligations under CONTRACT until FINAL CERTIFICATE shall have been given by the ENGINEER-IN-CHARGE notwithstanding any previous entry upon the WORK and taking possession, working or using of the same or any part thereof by the EMPLOYER.

**96 Certificate and payments on evidence of completion:**

96.1

Except the FINAL CERTIFICATE, no other certificates or payments against a certificate or on general account shall be taken to be an admission by the EMPLOYER of the due performance of the CONTRACT or any part thereof or of occupancy or validity of any claim by the CONTRACTOR.

**97 Deductions from the contract price:**

97.1

All costs, damages or expenses which EMPLOYER may have paid or incurred, which under the provisions of the CONTRACT, the CONTRACTOR is liable/will be liable, will be claimed by the EMPLOYER. All such claims shall be billed by the EMPLOYER to the CONTRACTOR regularly as and when they fall due. Such claims shall be paid by the CONTRACTOR within 15 (fifteen) days of the receipt of the corresponding bills and if not paid by the CONTRACTOR within the said period, the EMPLOYER may, then, deduct the amount from any moneys due i.e., Contract Performance Security or becoming due to the CONTRACTOR under the CONTRACT or may be recovered by actions of law or otherwise, if the CONTRACTOR fails to satisfy the EMPLOYER of such claims.

**SECTION-VII Taxes and Insurance**

**98 Taxes, Duties, Octroi etc:**

98.1

The CONTRACTOR agrees to and does hereby accept full and exclusive liability for the payment of any and all Taxes, Duties, including Excise duty, octroi etc. now or hereafter imposed, increased, modified, all the sales taxes, duties, octrois etc. now in force and hereafter increased, imposed or modified, from time to time in respect of WORKS and materials and all contributions and taxes for unemployment compensation, insurance and old age pensions or annuities now or hereafter imposed by any Central or State Government authorities which are imposed with respect to or covered by the wages, salaries, or other compensations paid to the persons employed by the CONTRACTOR and the CONTRACTOR shall be responsible for the compliance of all SUB-CONTRACTORS, with all applicable Central, State, Municipal and local law and regulation and requirement of any Central, State or local Government agency or authority. CONTRACTOR further agrees to defend, indemnify and hold EMPLOYER harmless from any liability or penalty which may be imposed by the Central, State or Local authorities by reason or any violation by CONTRACTOR or



**ELECTRICAL WORKS (SUPPLY & ERECTION)  
FOR ALTERNATE POWER SUPPLY  
ARRANGEMENT OF VIKARMPUR GUEST HOUSE  
AT TALCHER FERTILIZERS LTD., ANGUL, ODISHA  
GENERAL CONDITIONS OF CONTRACT**

PC-183 /E/8001/S-IV

0

DOC. NO.

REV.

Page 54 of 67



SUB-CONTRACTOR of such laws, suits or proceedings that may be brought against the EMPLOYER arising under, growing out of, or by reason of the work provided for by this CONTRACT, by third parties, or by Central or State Government authority or any administrative sub-division thereof.

Tax deductions will be made as per the rules and regulations in force in accordance with acts prevailing from time to time.

**99 Sales tax/turnover tax:** 99.1 Tenderer should quote all inclusive prices including the liability of Sales Tax/Turnover Tax whether on the works contract as a whole or in respect of bought out components used by the CONTRACTOR in execution of the CONTRACT. EMPLOYER shall not be responsible for any such liability of the CONTRACTOR in respect of this CONTRACT.

**100 Statutory variations** 100.1 Tenderer should quote prices inclusive of excise-duty and sales tax applicable on finished product. Any statutory variations in Excise Duty and sales tax on finished product during the contractual completion period, shall be to the Employer's account for which the Contractor will furnish documentary evidence(s) in support of their claims to TFL. However, any increase in the rate of these taxes and duties (E.D. and S.T.) beyond the contractual completion period shall be to Contractor's account and any decrease shall be passed on to TFL.

**101 Insurance:** 101.1 GENERAL  
CONTRACTOR shall at his own expense arrange secure and maintain insurance with reputable insurance companies to the satisfaction of the EMPLOYER as follows:

CONTRACTOR at his cost shall arrange, secure and maintain insurance as may be necessary and to its full value for all such amounts to protect the WORKS in progress from time to time and the interest of EMPLOYER against all risks as detailed herein. The form and the limit of such insurance, as defined here in together with the under works thereof in each case should be as acceptable to the EMPLOYER. However, irrespective of work acceptance the responsibility to maintain adequate insurance coverage at all times during the period of CONTRACT shall be that of CONTRACTOR alone. CONTRACTOR's failure in this regard shall not relieve him of any of his responsibilities and obligations under CONTRACT.

Any loss or damage to the equipment, during ocean transportation, port/custom clearance, inland and port handling, inland transportation, storage, erection and commissioning till such time the WORK is taken over by EMPLOYER, shall be to the account of CONTRACTOR. CONTRACTOR shall be responsible for preferring of all claims and make good for the damage or loss by way of repairs and/or replacement of the parts of the Work damaged or lost. CONTRACTOR shall provide the EMPLOYER with a copy of all insurance policies and documents taken out by him in pursuance of the CONTRACT. Such copies of document shall be submitted to the EMPLOYER immediately upon the CONTRACTOR having taken such insurance coverage. CONTRACTOR shall also inform the EMPLOYER at least 60(Sixty) days in advance regarding the expiry cancellation and/or changes in any of such documents and ensure revalidation/renewal etc., as may be necessary well in time.

Statutory clearances, if any, in respect of foreign supply required for the purpose of replacement of equipment lost in transit and/or during erection, shall be made available by the EMPLOYER. CONTRACTOR shall, however, be responsible for obtaining requisite licenses, port clearances and other formalities relating to



**ELECTRICAL WORKS (SUPPLY & ERECTION)  
FOR ALTERNATE POWER SUPPLY  
ARRANGEMENT OF VIKARMPUR GUEST HOUSE  
AT TALCHER FERTILIZERS LTD., ANGUL, ODISHA  
GENERAL CONDITIONS OF CONTRACT**

PC-183 /E/8001/S-IV

0

DOC. NO.

REV.

Page 55 of 67



such import. The risks that are to be covered under the insurance shall include, but not be limited to the loss or damage in handling, transit, theft, pilferage, riot, civil commotion, weather conditions, accidents of all kinds, fire, war risk (during ocean transportation only) etc. The scope of such insurance shall cover the entire value of supplies of equipments, plants and materials to be imported from time to time.

All costs on account of insurance liabilities covered under CONTRACT will be to CONTRACTOR's account and will be included in VALUE OF CONTRACT. However, the EMPLOYER may from time to time, during the currency of the CONTRACT, ask the CONTRACTOR in writing to limit the insurance coverage risk and in such a case, the parties to the CONTRACT will agree for a mutual settlement, for reduction in VALUE OF CONTRACT to the extent of reduced premium amounts.

CONTRACTOR as far as possible shall cover insurance with Indian Insurance Companies, including marine Insurance during ocean transportation.

i) EMPLOYEES STATE INSURANCE ACT:

The CONTRACTOR agrees to and does hereby accept full and exclusive liability for the compliance with all obligations imposed by the Employee State Insurance Act 1948 and the CONTRACTOR further agrees to defend, indemnify and hold EMPLOYER harmless for any liability or penalty which may be imposed by the Central, State or Local authority by reason of any asserted violation by CONTRACTOR or SUB-CONTRACTOR of the Employees' State Insurance Act, 1948, and also from all claims, suits or proceeding that may be brought against the EMPLOYER arising under, growing out of or by reasons of the work provided for by this CONTRACTOR, by third parties or by Central or State Government authority or any political sub- division thereof.

The CONTRACTOR agrees to fill in with the Employee's State Insurance Corporation, the Declaration Forms, and all forms which may be required in respect of the CONTRACTOR's or SUB-CONTRACTOR's employees, who are employed in the WORK provided for or those covered by ESI from time to time under the Agreement. The CONTRACTOR shall deduct and secure the agreement of the SUB- CONTRACTOR to deduct the employee's contribution as per the first schedule of the Employee's State Insurance Act from wages and affix the Employees Contribution Card at wages payment intervals. The CONTRACTOR shall remit and secure the agreement of SUB-CONTRACTOR to remit to the State Bank of India, Employee's State Insurance Corporation Account, the Employee's contribution as required by the Act. The CONTRACTOR agrees to maintain all cards and Records as required under the Act in respect of employees and payments and the CONTRACTOR shall secure the agreement of the SUB- CONTRACTOR to maintain such records. Any expenses incurred for the contributions, making contributions or maintaining records shall be to the CONTRACTOR's or SUB-CONTRACTOR's account.

The EMPLOYER shall retain such sum as may be necessary from the total VALUE OF CONTRACT until the CONTRACTOR shall furnish satisfactory proof that all contributions as required by the Employees State Insurance Act, 1948, have been paid. This will be pending on the CONTRACTOR when the ESI Act is extended to the place of work.

ii) WORKMEN COMPENSATION AND EMPLOYER'S



**ELECTRICAL WORKS (SUPPLY & ERECTION)  
FOR ALTERNATE POWER SUPPLY  
ARRANGEMENT OF VIKARMPUR GUEST HOUSE  
AT TALCHER FERTILIZERS LTD., ANGUL, ODISHA  
GENERAL CONDITIONS OF CONTRACT**

PC-183 /E/8001/S-IV

0

DOC. NO.

REV.

Page 56 of 67



LIABILITY INSURANCE:

Insurance shall be effected for all the CONTRACTOR's employees engaged in the performance of this CONTRACT. If any of the work is sublet, the CONTRACTOR shall require the SUB-CONTRACTOR to provide workman's Compensation and employer's liability insurance for the later's employees if such employees are not covered under the CONTRACTOR's Insurance.

iii) ACCIDENT OR INJURY TO WORKMEN:

The EMPLOYER shall not be liable for or in respect of any damages or compensation payable at law in respect or in consequence of any accident or injury to any workman or other person in the Employment of the CONTRACTOR or any SUB-CONTRACTOR save and except an accident or injury resulting from any act or default of the EMPLOYER, his agents or servants and the CONTRACTOR shall indemnify and keep indemnified the EMPLOYER against all such damages and compensation (save and except and aforesaid) and against all claims, demands, proceeding, costs, charges and expenses, whatsoever in respect or in relation thereto.

iv) TRANSIT INSURANCE

In respect of all items to be transported by the CONTRACTOR to the SITE of WORK, the cost of transit insurance should be borne by the CONTRACTOR and the quoted price shall be inclusive of this cost.

V) COMPREHENSIVE AUTOMOBILE INSURANCE

This insurance shall be in such a form as to protect the Contractor against all claims for injuries, disability, disease and death to members of public including EMPLOYER's men and damage to the property of others arising from the use of motor vehicles during on or off the 'site' operations, irrespective of the Employership of such vehicles.

VI) COMPREHENSIVE GENERAL LIABILITY INSURANCE

- a) This insurance shall protect the Contractor against all claims arising from injuries, disabilities, disease or death of member of public or damage to property of others due to any act or omission on the part of the Contractor, his agents, his employees, his representatives and Sub-Contractor's or from riots, strikes and civil commotion.
- b) Contractor shall take suitable Group Personal Accident Insurance Cover for taking care of injury, damage or any other risks in respect of his Engineers and other Supervisory staff who are not covered under Employees State Insurance Act.
- c) The policy shall cover third party liability. The third party (liability shall cover the loss/ disablement of human life (person not belonging to the Contractor) and also cover the risk of damage to others materials/ equipment/ properties during construction, erection and commissioning at site. The value of third party liability for compensation for loss of



**ELECTRICAL WORKS (SUPPLY & ERECTION)  
FOR ALTERNATE POWER SUPPLY  
ARRANGEMENT OF VIKARMPUR GUEST HOUSE  
AT TALCHER FERTILIZERS LTD., ANGUL, ODISHA  
GENERAL CONDITIONS OF CONTRACT**

PC-183 /E/8001/S-IV

0

DOC. NO.

REV.

Page 57 of 67



human life or partial/full disablement shall be of required statutory value but not less than Rs. 2 lakhs per death, Rs. 1.5 lakhs per full disablement and Rs. 1 lakh per partial disablement and shall nevertheless cover such compensation as may be awarded by Court by Law in India and cover for damage to others equipment/ property as approved by the Purchaser. However, third party risk shall be maximum to Rs. 10(ten) lakhs to death.

- d) The Contractor shall also arrange suitable insurance to cover damage, loss, accidents, risks etc., in respect of all his plant, equipments and machinery, erection tools & tackles and all other temporary attachments brought by him at site to execute the work.
- e) The Contractor shall take out insurance policy in the joint name of EMPLOYER and Contractor from one or more nationalized insurance company from any branch office at Project site.
- f) Any such insurance requirements as are hereby established as the minimum policies and coverage which Contractor must secure and keep in force must be complied with, Contractor shall at all times be free to obtain additional or increased coverage at Contractor's sole expenses.

vii) ANY OTHER INSURANCE REQUIRED UNDER LAW OR REGULATIONS OR BY EMPLOYER:

CONTRACTOR shall also carry and maintain any and all other insurance(s) which he may be required under any law or regulation from time to time without any extra cost to EMPLOYER. He shall also carry and maintain any other insurance which may be required by the EMPLOYER.

**102 Damage to Property or to any Person or any Third Party**

102.1 i)

CONTRACTOR shall be responsible for making good to the satisfaction of the EMPLOYER any loss or any damage to structures and properties belonging to the EMPLOYER or being executed or procured or being procured by the EMPLOYER or of other agencies within in the premises of all the work of the EMPLOYER, if such loss or damage is due to fault and/or the negligence or willful acts or omission of the CONTRACTOR, his employees, agents, representatives or SUB-CONTRACTORS.

ii)

The CONTRACTOR shall take sufficient care in moving his plants, equipments and materials from one place to another so that they do not cause any damage to any person or to the property of the EMPLOYER or any third party including overhead and underground cables and in the event of any damage resulting to the property of the EMPLOYER or of a third party during the movement of the aforesaid plant, equipment or materials the cost of such damages including eventual loss of production, operation or services in any plant or establishment as estimated by the EMPLOYER or ascertained or demanded by the third party shall be borne by the CONTRACTOR. Third party liability risk shall be Rupees One lakh for single accident and limited to Rupees Ten lakhs.

iii)

The CONTRACTOR shall indemnify and keep the EMPLOYER





**ELECTRICAL WORKS (SUPPLY & ERECTION)  
FOR ALTERNATE POWER SUPPLY  
ARRANGEMENT OF VIKARMPUR GUEST HOUSE  
AT TALCHER FERTILIZERS LTD., ANGUL, ODISHA  
GENERAL CONDITIONS OF CONTRACT**

PC-183 /E/8001/S-IV

0

DOC. NO.

REV.

Page 58 of 67



harmless of all claims for damages to property other than EMPLOYER's property arising under or by reason of this agreement, if such claims result from the fault and/or negligence or willful acts or omission of the CONTRACTOR, his employees, agents, representative of SUB-CONTRACTOR.

**SECTION-VIII Labour Laws**

**103 Labour laws:**

- 103.1 i) No labour below the age of 18 (eighteen) years shall be employed on the WORK.
- ii) The CONTRACTOR shall not pay less than what is provided under law to labourers engaged by him on the WORK.
- iii) The CONTRACTOR shall at his expense comply with all labour laws and keep the EMPLOYER indemnified in respect thereof.
- iv) The CONTRACTOR shall pay equal wages for men and women in accordance with applicable labour laws.
- v) If the CONTRACTOR is covered under the Contract labour (Regulation and Abolition) Act, he shall obtain a licence from licensing authority (i.e. office of the labour commissioner) by payment of necessary prescribed fee and the deposit, if any, before starting the WORK under the CONTRACT. Such fee/deposit shall be borne by the CONTRACTOR.
- vi) The CONTRACTOR shall employ labour in sufficient numbers either directly or through SUB- CONTRACTOR's to maintain the required rate of progress and of quality to ensure workmanship of the degree specified in the CONTRACT and to the satisfaction of the ENGINEER-IN-CHARGE.
- vii) The CONTRACTOR shall furnish to the ENGINEER-IN- CHARGE the distribution return of the number and description, by trades of the work people employed on the works. The CONTRACTOR shall also submit on the 4th and 19th of every month to the ENGINEER-IN-CHARGE a true statement showing in respect of the second half of the preceding month and the first half of the current month (1) the accidents that occurred during the said fortnight showing the circumstances under which they happened and the extent of damage and injury caused by them and (2) the number of female workers who have been allowed Maternity Benefit as provided in the Maternity Benefit Act 1961 on Rules made there under and the amount paid to them.
- viii) The CONTRACTOR shall comply with the provisions of the payment of Wage Act 1936, Employee Provident Fund Act 1952, Minimum Wages Act 1948. Employers Liability Act 1938. Workmen's Compensation Act 1923, Industrial Disputes Act 1947, the Maternity Benefit Act 1961 and Contract Labour Regulation and Abolition Act 1970, Employment of Children Act 1938 or any modifications thereof or any other law relating thereto and rules made there under from time to time.
- ix) The ENGINEER-IN-CHARGE shall on a report having been made by an Inspecting Officer as defined in Contract Labour (Regulation and





**ELECTRICAL WORKS (SUPPLY & ERECTION)  
FOR ALTERNATE POWER SUPPLY  
ARRANGEMENT OF VIKARMPUR GUEST HOUSE  
AT TALCHER FERTILIZERS LTD., ANGUL, ODISHA  
GENERAL CONDITIONS OF CONTRACT**

PC-183 /E/8001/S-IV

0

DOC. NO.

REV.

Page 59 of 67



Abolition) Act 1970 have the power to deduct from the money due to the CONTRACTOR any sum required or estimated to be required for making good the loss suffered by a worker or workers by reason of non-fulfillment of the Conditions of the Contract for the benefit of workers, non-payment of wages or of deductions made from his or their wages which are not justified by the terms of the Contract or non-observance of the said regulations.

- x) The CONTRACTOR shall indemnify the EMPLOYER against any payments to be made under and for the observance of the provisions of the aforesaid Acts without prejudice to his right to obtain indemnity from his SUB-CONTRACTOR's. In the event of the CONTRACTOR committing a default or breach of any of the provisions of the aforesaid Acts as amended from time to time, of furnishing any information or submitting or filling and Form/ Register/ Slip under the provisions of these Acts which is materially incorrect then on the report of the inspecting Officers, the CONTRACTOR shall without prejudice to any other liability pay to the EMPLOYER a sum not exceeding Rs.50.00 as Liquidated Damages for every default, breach or furnishing, making, submitting, filling materially incorrect statement as may be fixed by the ENGINEER-IN- CHARGE and in the event of the CONTRACTOR's default continuing in this respect, the Liquidated Damages may be enhanced to Rs.50.00 per day for each day of default subject to a maximum of one percent of the estimated cost of the WORK put to tender. The ENGINEER-IN-CHARGE shall deduct such amount from bills or Contract Performance Security of the CONTRACTOR and credit the same to the Welfare Fund constitute under these acts. The decision of the ENGINEER-IN-CHARGE in this respect shall be final and binding.

**104 Implementation of apprentices act, 1961:**

104.1

The CONTRACTOR shall comply with the provisions of the Apprentices Act, 1961 and the Rules and Orders issued there under from time to time. If he fails to do so, his failure will be a breach of the CONTRACT and the ENGINEER-IN-CHARGE may, at his discretion, cancel the CONTRACT. The CONTRACTOR shall also be liable for any pecuniary liability arising on account of any violation by him of the provisions, of the Act.

**105 Contractor to indemnify the employer:**

105.1 i)

The CONTRACTOR shall indemnify the EMPLOYER and every member, office and employee of the EMPLOYER, also the ENGINEER-IN-CHARGE and his staff against all actions, proceedings, claims, demands, costs and expenses whatsoever arising out of or in connection with the matters referred to in Clause 102.0 and elsewhere and all actions, proceedings, claims, demands, costs and expenses which may be made against the EMPLOYER for or in respect of or arising out of any failure by the CONTRACTOR in the performance of his obligations under the CONTRACT DOCUMENT. The EMPLOYER shall not be liable for or in respect of or arising out of any failure by the CONTRACTOR in the performance of his obligations under the CONTRACT DOCUMENT. The EMPLOYER shall not be liable for or in respect of any demand or compensation payable by law in respect or in consequence of any accident or injury to any workmen or other person. In the employment of the CONTRACTOR or his SUB-CONTRACTOR the CONTRACTOR shall indemnify and keep indemnified the EMPLOYER against all such damages and compensations and against all claims, damages, proceedings, costs, charges and expenses whatsoever in respect thereof



**ELECTRICAL WORKS (SUPPLY & ERECTION)  
FOR ALTERNATE POWER SUPPLY  
ARRANGEMENT OF VIKARMPUR GUEST HOUSE  
AT TALCHER FERTILIZERS LTD., ANGUL, ODISHA  
GENERAL CONDITIONS OF CONTRACT**

PC-183 /E/8001/S-IV

0

DOC. NO.

REV.

Page 60 of 67



or in relation thereto.

ii) PAYMENT OF CLAIMS AND DAMAGES:

Should the EMPLOYER have to pay any money in respect of such claims or demands as aforesaid the amount so paid and the costs incurred by the EMPLOYER shall be charged to and paid by the CONTRACTOR and the CONTRACTOR shall not be at liberty to dispute or question the right of the EMPLOYER to make such payments notwithstanding the same, may have been made without the consent or authority or in law or otherwise to the contrary.

iii) In every case in which by virtue of the provisions of Section 12, Sub-section (i) of workmen's compensation Act, 1923 or other applicable provision of Workmen Compensation Act or any other Act, the EMPLOYER is obliged to pay compensation to a workman employed by the CONTRACTOR in execution of the WORK, the EMPLOYER will recover from the CONTRACTOR the amount of the compensation so paid, and without prejudice to the rights of EMPLOYER under Section 12, Sub-section (2) of the said act, EMPLOYER shall be at liberty to recover such amount or any part thereof by deducting it from the Contract Performance Security or from any sum due to the CONTRACTOR whether under this CONTRACT or otherwise. The EMPLOYER shall not be bound to contest any claim made under Section 12, Sub-section (i) of the said act, except on the written request of the CONTRACTOR and upon his giving to the EMPLOYER full security for all costs for which the EMPLOYER might become liable in consequence of contesting such claim.

**106 Health and sanitary arrangements for workers:**

- 106.1 In respect of all labour directly or indirectly employed in the WORKS for the performance of the CONTRACTOR's part of this agreement, the CONTRACTOR shall comply with or cause to be complied with all the rules and regulations of the local sanitary and other authorities or as framed by the EMPLOYER from time to time for the protection of health and sanitary arrangements for all workers.
- 106.2 The CONTRACTOR shall provide in the labour colony all amenities such as electricity, water and other sanitary and health arrangements. The CONTRACTOR shall also provide necessary surface transportation to the place of work and back to the colony for their personnel accommodated in the labour colony.

**SECTION-IX Applicable Laws and Settlement of Disputes**

**107 Arbitration:**

- 107.1 Unless otherwise specified, the matters where decision of the Engineer-in-Charge is deemed to be final and binding as provided in the Agreement and the issues/disputes which cannot be mutually resolved within a reasonable time, all disputes shall be referred to arbitration by Sole Arbitrator.

The Employer [Talcher Fertilizers Ltd.] shall suggest a panel of three independent and distinguished persons to the bidder/contractor/supplier/buyer (as the case may be) to select any one among them to act as the Sole Arbitrator.

In the event of failure of the other parties to select the Sole Arbitrator within 30 days from the receipt of the communication suggesting the panel of arbitrators, the right of selection of the sole arbitrator by the other party shall stand forfeited and the EMPLOYER (TFL) shall have discretion to proceed



**ELECTRICAL WORKS (SUPPLY & ERECTION)  
FOR ALTERNATE POWER SUPPLY  
ARRANGEMENT OF VIKARMPUR GUEST HOUSE  
AT TALCHER FERTILIZERS LTD., ANGUL, ODISHA  
GENERAL CONDITIONS OF CONTRACT**

PC-183 /E/8001/S-IV

0

DOC. NO.

REV.

Page 61 of 67



with the appointment of the Sole Arbitrator. The decision of Employer on the appointment of the sole arbitrator shall be final and binding on the parties.

The award of sole arbitrator shall be final and binding on the parties and unless directed/awarded otherwise by the sole arbitrator, the cost of arbitration proceedings shall be shared equally by the parties. The Arbitration proceedings shall be in English language and venue shall be New Delhi, India.

Subject to the above, the provisions of (Indian) Arbitration & Conciliation ACT 1996 and the Rules framed there under shall be applicable. All matter relating to this contract are subject to the exclusive jurisdiction of the court situated in the state of Delhi.

Bidders/suppliers/contractors may please note that the Arbitration & Conciliation Act 1996 was enacted by the Indian Parliament and is based on United Nations Commission on International Trade Law (UNCITRAL model law), which were prepared after extensive consultation with Arbitral Institutions and centers of International Commercial Arbitration. The United Nations General Assembly vide resolution 31/98 adopted the UNCITRAL Arbitration rules on 15 December 1976.

107.2 FOR THE SETTLEMENT OF DISPUTES BETWEEN GOVERNMENT DEPARTMENT AND ANOTHER AND ONE GOVERNMENT DEPARTMENT AND PUBLIC ENTERPRISE AND ONE PUBLIC ENTERPRISE AND ANOTHER THE ARBITRATION SHALL BE AS FOLLOWS:

"In the event of any dispute or difference between the parties hereto, such dispute or difference shall be resolved amicably by mutual consultation or through the good offices of empowered agencies of the Government. If such resolution is not possible, then, the unresolved dispute or difference shall be referred to arbitration of an arbitrator to be nominated by Secretary, Department of Legal Affairs ("Law Secretary") in terms of the Office Memorandum No.55/3/1/75-CF, dated the 19th December 1975 issued by the Cabinet Secretariat (Department of Cabinet Affairs), as modified from time to time. The Arbitration Act 1940 (10 of 1940) shall not be applicable to the arbitration under this clause. The award of the Arbitrator shall be binding upon parties to the dispute. Provided, however, any party aggrieved by such award may make a further reference for setting aside or revision of the award to Law Secretary whose decision shall bind the parties finally and conclusively.

**108 Jurisdiction:**

The CONTRACT shall be governed by and constructed according to the laws in force in INDIA. The CONTRACTOR hereby submits to the jurisdiction of the Courts situated at DELHI for the purposes of disputes, actions and proceedings arising out of the CONTRACT, the courts at DELHI only will have the jurisdiction to hear and decide such disputed, actions and proceedings.

**SECTION-X Safety Codes**

**109 General:**

109.1 CONTRACTOR shall adhere to safe construction practice and guard against hazardous, and unsafe working conditions and shall comply with EMPLOYER's safety rules as set forth herein. Prior to start of construction, CONTRACTOR will be furnished copies of EMPLOYER's "Safety Code" for information and guidance, if it has been prepared.

**110 Safety regulations:**

110.1 i) In respect of all labour, directly employed in the WORK for the



**ELECTRICAL WORKS (SUPPLY & ERECTION)  
FOR ALTERNATE POWER SUPPLY  
ARRANGEMENT OF VIKARMPUR GUEST HOUSE  
AT TALCHER FERTILIZERS LTD., ANGUL, ODISHA  
GENERAL CONDITIONS OF CONTRACT**

PC-183 /E/8001/S-IV

0

DOC. NO.

REV.

Page 62 of 67



performance of CONTRACTOR's part of this agreement, the CONTRACTOR shall at his own expense arrange for all the safety provisions as per safety codes of C.P.W.D., Indian Standards Institution. The Electricity Act, The Mines Act and such other acts as applicable.

- ii) The CONTRACTOR shall observe and abide by all fire and safety regulations of the EMPLOYER. Before starting construction work CONTRACTOR shall consult with EMPLOYER's safety Engineers or ENGINEER- IN-CHARGE and must make good to the satisfaction of the EMPLOYER any loss or damage due to fire to any portion of the work done or to be done under this agreement or to any of the EMPLOYER's existing property.
- 111 First aid and industrial injuries:** 111.0
- i) CONTRACTOR shall maintain first aid facilities for its employees and those of its SUB-CONTRACTOR.
- ii) CONTRACTOR shall make outside arrangements for ambulance service and for the treatment of industrial injuries. Names of those providing these services shall be furnished to EMPLOYER prior to start of construction and their telephone numbers shall be prominently posted in CONTRACTOR's field office.
- iii) All critical industrial injuries shall be reported promptly to EMPLOYER, and a copy of CONTRACTOR's report covering each personal injury requiring the attention of a physician shall be furnished to the EMPLOYER.
- 112 General rules:** 112.0 Smoking within the battery area, tank farm or dock limits is strictly prohibited. Violators of the no smoking rules shall be discharged immediately.
- 113 Contractor's barricades:.** 113.0
- i) CONTRACTOR shall erect and maintain barricades required in connection with his operation to guard or protect:-
- a) Excavations
- b) Hoisting Areas.
- c) Areas adjudged hazardous by CONTRACTOR's or EMPLOYER's inspectors.
- d) EMPLOYER's existing property subject to damage by CONTRACTOR's Operations.
- e) Rail Road unloading spots.
- ii) CONTRACTOR's employees and those of his SUB-CONTRACTOR's shall become acquainted with EMPLOYER's barricading practice and shall respect the provisions thereof.
- iii) Barricades and hazardous areas adjacent to, but not located in normal routes of travel shall be marked by red flasher lanterns at nights.
- 114 Scaffolding:** 114.1 i) Suitable scaffolding should be provided for workmen for all works that cannot safely be done from the ground or from solid construction except such short period work as can be done safely from ladders. When a ladder is used an extra Mazdoor shall be engaged for holding the ladder



**ELECTRICAL WORKS (SUPPLY & ERECTION)  
FOR ALTERNATE POWER SUPPLY  
ARRANGEMENT OF VIKARMPUR GUEST HOUSE  
AT TALCHER FERTILIZERS LTD., ANGUL, ODISHA  
GENERAL CONDITIONS OF CONTRACT**

PC-183 /E/8001/S-IV

0

DOC. NO.

REV.

Page 63 of 67



and if the ladder is used for carrying material as well, suitable footholds and handholds shall be provided on the ladder and the ladder shall be given an inclination not steeper than 1 in 4 (1 horizontal and 4 vertical).

- ii) Scaffolding or staging more than 4 metres above the ground or floor, swing suspended from an overhead support or erected with stationary support shall have a guard rail properly attached, bolted, braced and otherwise retarded at least one metre high above the floor or platform of such scaffolding or staging and extending along the entire length of the outside and ends thereof with only such openings as may be necessary for the delivery of materials. Such scaffolding or staging shall be so fastened as to prevent it from swaying from the building or structure.
- iii) Working platform, gangway and stairway should be so constructed that they should not sag unduly or unequally and if the height of platform of the gangway or the stairway is more than 4 metres above the ground level or floor level, they should be closely boarded, should have adequate width and should be suitably fastened as in ii) above.
- iv) Every opening in the floor of a building or in a working platform shall be provided with suitable means to prevent the fall of persons or materials by providing suitable fencing or railing whose minimum heights shall be 1 metre.
- v) Safe-means of access shall be provided to all working platforms and other working places, every ladder shall be securely fixed. No portable single ladder shall be over 9 metres in length while the width between side rails in rung ladder shall in no case be less than 30 cms for ladder upto and including 3 metres in length. For longer ladder this width should be increased 5mm for each additional foot of length. Uniform steps spacing shall not exceed 30 cms. Adequate precautions shall be taken to prevent danger from electrical equipment. No materials on any of the sites or work shall be so stacked or placed to cause danger or inconvenience to any person or public. The CONTRACTOR shall also provide all necessary fencing and lights to protect the workers and staff from accidents, and shall be bound to bear the expenses of defense of every suit, action or other proceeding of law that may be brought by any person for injury sustained owing to neglect of the above precautions and pay any damages and costs which may be awarded in any such suit or action or proceeding to any such person or which may with the consent of the CONTRACTOR be paid to compromise any claim by any such person.

**115 Excavation and trenching:** 115.1 All trenches 1.2 metres or more in depth, shall at all times be supplied with at least one ladder for each 50 metres length or fraction thereof.

Ladder shall be extended from bottom of the trenches to atleast 1 metre above the surface of the ground. The sides of the trenches which are 1.5M in depth shall be stepped back to give suitable slope or securely held by timber bracing, so as to avoid the danger of sides to collapse. The excavated materials shall not be placed within 1.5 metres of the edge of the trench or half of the trench width whichever is more. Cutting shall be done from top to bottom. Under no circumstances undermining or under-cutting shall be done.

**116 Demolition/general safety:** 116.1

- i) Before any demolition work is commenced and also during the progress of the demolition work
- a) All roads and open areas adjacent to the work site shall either



**ELECTRICAL WORKS (SUPPLY & ERECTION)  
FOR ALTERNATE POWER SUPPLY  
ARRANGEMENT OF VIKARMPUR GUEST HOUSE  
AT TALCHER FERTILIZERS LTD., ANGUL, ODISHA  
GENERAL CONDITIONS OF CONTRACT**

PC-183 /E/8001/S-IV

0

DOC. NO.

REV.

Page 64 of 67



be closed or suitably protected.

- b) No electric cable or apparatus which is liable to be a source of danger shall remain electrically charged.
- c) All practical steps shall be taken to prevent danger to persons employed from risk of fire or explosion or flooding. No floor, roof or other part of the building shall be so overloaded with debris or materials as to render it unsafe.
  - ii) All necessary personal safety equipment as considered adequate by the ENGINEER-IN-CHARGE, should be kept available for the use of the persons employed on the SITE and maintained in condition suitable for immediate use, and the CONTRACTOR shall take adequate steps to ensure proper use of equipment by those concerned.
- a) Workers employed on mixing asphaltic materials, cement and lime mortars shall be provided with protective footwear and protective gloves.
- b) Those engaged in white washing and mixing or stacking or cement bags or any material which are injurious to the eyes be provided with protective goggles.
- c) Those engaged in welding and cutting works shall be provided with protective face & eye shield, hand gloves, etc.
- d) Stone breakers shall be provided with protective goggles and protective clothing and seated at sufficiently safe intervals.
- e) When workers are employed in sewers and manholes, which are in use, the CONTRACTOR shall ensure that the manhole covers are opened and are ventilated atleast for an hour before the workers are allowed to get into the manholes, and the manholes so opened shall be cordoned off with suitable railing and provided with warning signals or board to prevent accident to the public.
- f) The CONTRACTOR shall not employ men below the age of 18 years and women on the work of painting with products containing lead in any form. Wherever men above the age of 18 years are employed on the work of lead painting, the following precautions should be taken.
  - 1) No paint containing lead or lead product shall be used except in the form of paste or readymade paint.
  - 2) Suitable face masks should be supplied for use by the workers when paint is applied in the form of spray or a surface having lead paint dry rubbed and scrapped.
  - 3) Overalls shall be supplied by the CONTRACTOR to the workmen and adequate facilities shall be provided to enable the working painters to wash them during and on cessation of work.





**ELECTRICAL WORKS (SUPPLY & ERECTION)  
FOR ALTERNATE POWER SUPPLY  
ARRANGEMENT OF VIKARMPUR GUEST HOUSE  
AT TALCHER FERTILIZERS LTD., ANGUL, ODISHA  
GENERAL CONDITIONS OF CONTRACT**

PC-183 /E/8001/S-IV

0

DOC. NO.

REV.

Page 65 of 67



- iii) When the work is done near any place where there is risk of drowning, all necessary safety equipment should be provided and kept ready for use and all necessary steps taken for prompt rescue of any person in danger and adequate provision should be made for prompt first aid treatment of all injuries likely to be sustained during the course of the work.
- iv) Use of hoisting machines and tackles including their attachments, anchorage and supports shall conform to the following standards or conditions:
- a) These shall be of good mechanical construction, sound materials and adequate strength and free from patent defect and shall be kept in good working order.
- b) Every rope used in hoisting or lowering materials or as means of suspension shall be of durable quality and adequate strength and free from patent defects.
- c) Every crane driver or hoisting appliance operator shall be properly qualified and no person under the age of 21 years should be in charge of any hoisting machine including any scaffolding, winch or give signals to the operator.
- d) In case of every hoisting machine and of every chain ring hook, shackle, swivel, and pulley block used in hoisting or lowering or as means of suspension, the safe working load shall be ascertained by adequate means. Every hoisting machine and all gears referred to above shall be plainly marked with the safe working load of the conditions under which it is applicable and the same shall be clearly indicated. No part of any machine or any gear referred to above in this paragraph shall be loaded beyond safe working load except for the purpose of testing.
- e) In case of departmental machine, the safe working load shall be notified by the ENGINEER- IN-CHARGE. As regards CONTRACTOR's machines, the CONTRACTOR shall notify the safe working load of the machine to the ENGINEER-IN-CHARGE whenever he brings any machinery to SITE of WORK and get it verified by the Engineer concerned.
- v) Motors, gears, transmission lines, electric wiring and other dangerous parts of hoisting appliances should be provided with efficient safeguards. Hoisting appliances should be provided with such means as to reduce to minimum the accidental descent of the load, adequate precautions should be taken to reduce the minimum risk of any part or parts of a suspended load becoming accidentally displaced. When workers are employed on electrical installations which are already energized, insulating mats, wearing apparel, such as gloves, sleeves, and boots as may be necessary should be provided. The workers shall not wear any rings, watches and carry keys or other materials which are good conductors of electricity.
- vi) All scaffolds, ladders and other safety devices mentioned or described herein shall be maintained in safe conditions and no scaffolds, ladder or equipment shall be altered or removed while it is in use. Adequate washing facilities should be provided at or near places of work.





**ELECTRICAL WORKS (SUPPLY & ERECTION)  
FOR ALTERNATE POWER SUPPLY  
ARRANGEMENT OF VIKARMPUR GUEST HOUSE  
AT TALCHER FERTILIZERS LTD., ANGUL, ODISHA  
GENERAL CONDITIONS OF CONTRACT**

PC-183 /E/8001/S-IV

0

DOC. NO.

REV.

Page 66 of 67



- vii) These safety provisions should be brought to the notice of all concerned by displaying on a notice board at a prominent place at the work-spot. The person responsible for compliance of the safety code shall be named therein by the CONTRACTOR.
- viii) To ensure effective enforcement of the rules and regulations relating to safety precautions, the arrangements made by the CONTRACTOR shall be open to inspection by the Welfare Officer, ENGINEER-IN-CHARGE or safety Engineer of the Administration or their representatives.
- ix) Notwithstanding the above clauses there is nothing in these to exempt the CONTRACTOR for the operations of any other Act or rules in force in the Republic of India. The work throughout including any temporary works shall be carried out in such a manner as not to interfere in any way whatsoever with the traffic on any roads or footpath at the site or in the vicinity thereto or any existing works whether the property of the Administration or of a third party.

In addition to the above, the CONTRACTOR shall abide by the safety code provision as per C.P.W.D. Safety code and Indian Standard Safety Code from time to time.

- 117 Care in handling inflammable gas:** 117.1 The CONTRACTOR has to ensure all precautionary measures and exercise utmost care in handling the inflammable gas cylinder/inflammable liquids/paints etc. as required under the law and/or as advised by the fire Authorities of the EMPLOYER
- 118 Temporary combustible structures:** 118.1 Temporary combustible structures will not be built near or around work site.
- 119 Precautions against fire:** 119.1 The CONTRACTOR will have to provide Fire Extinguishers, Fire Buckets and drums at worksite as recommended by ENGINEER-IN-CHARGE. They will have to ensure all precautionary measures and exercise utmost care in handling the inflammable gas cylinders/ inflammable liquid/ paints etc. as advised by ENGINEER-IN-CHARGE. Temporary combustible structures will not be built near or around the work-site.
- 120 Explosives:** 120.1 Explosives shall not be stored or used on the WORK or on the SITE by the CONTRACTOR without the permission of the ENGINEER-IN-CHARGE in writing and then only in the manner and to the extent to which such permission is given. When explosives are required for the WORK they will be stored in a special magazine to be provided at the cost of the CONTRACTOR in accordance with the Explosives Rules. The CONTRACTOR shall obtain the necessary licence for the storage and the use of explosives and all operations in which or for which explosives are employed shall be at sole risk and responsibility of the CONTRACTOR and the CONTRACTOR shall indemnify the EMPLOYER against any loss or damage resulting directly or indirectly therefrom.
- 121 Mines act:** 121.1 SAFETY CODE: The CONTRACTOR shall at his own expense arrange for the safety provisions as required by the ENGINEER-IN-CHARGE in respect of all labour directly employed for performance of the WORKS and shall provide all facilities in connection therewith. In case the CONTRACTOR fails to make arrangements and provides necessary facilities as aforesaid, the ENGINEER-IN-



**ELECTRICAL WORKS (SUPPLY & ERECTION)  
FOR ALTERNATE POWER SUPPLY  
ARRANGEMENT OF VIKARMPUR GUEST HOUSE  
AT TALCHER FERTILIZERS LTD., ANGUL, ODISHA  
GENERAL CONDITIONS OF CONTRACT**

PC-183 /E/8001/S-IV

0

DOC. NO.

REV.

Page 67 of 67



CHARGE shall be entitled to do so and recover the costs thereof from the CONTRACTOR.

121.2 Failure to comply with Safety Code or the provisions relating to report on accidents and to grant of maternity benefits to female workers shall make the CONTRACTOR liable to pay Company Liquidated Damages an amount not exceeding Rs.50/- for each default or materially incorrect statement. The decision of the ENGINEER-IN-CHARGE in such matters based on reports from the Inspecting Officer or from representatives of ENGINEER-IN-CHARGE shall be final and binding and deductions for recovery of such Liquidated Damages may be made from any amount payable to the CONTRACTOR from all the provisions of the Mines Act, 1952 or any statutory modifications or re-enactment thereof the time being in force and any Rules and Regulations made there under in respect of all the persons employed by him under this CONTRACT and shall indemnify the EMPLOYER from and against any claim under the Mines Act or the rules and regulations framed there under by or on behalf of any persons employed by him or otherwise.

**122 Preservation of place:**

122.1 The CONTRACTOR shall take requisite precautions and use his best endeavors to prevent any riotous or unlawful behavior by or amongst his worker and others employed or the works and for the preservation of peace and protection of the inhabitants and security of property in the neighborhood of the WORK. In the event of the EMPLOYER requiring the maintenance of a Special Police Force at or in the vicinity of the site during the tenure of works, the expenses thereof shall be borne by the CONTRACTOR and if paid by the EMPLOYER shall be recoverable from the CONTRACTOR.

**123 Outbreak of infectious diseases:**

123.1 The CONTRACTOR shall remove from his camp such labour and their facilities who refuse protective inoculation and vaccination when called upon to do so by the ENGINEER-IN-CHARGE's representative. Should Cholera, Plague or other infectious diseases break out the CONTRACTOR shall burn the huts, beddings, clothes and other belongings or used by the infected parties and promptly erect new huts on healthy sites as required by the ENGINEER-IN-CHARGE failing which within the time specified in the Engineer's requisition, the work may be done by the EMPLOYER and the cost thereof recovered from the CONTRACTOR.

**124 Use of intoxicants:**



124.1 The unauthorized sale of spirits or other intoxicants, beverages upon the work in any of the buildings, encampments or tenements owned, occupied by or within the control of the CONTRACTOR or any of his employee is forbidden and the CONTRACTOR shall exercise his influence and authority to the utmost extent to secure strict compliance with this condition.

In addition to the above, the CONTRACTOR shall abide by the safety code provision as per C.P.W.D. safety code and Indian Standard Code framed from time to time.

 <b>पी डी आई एल</b> <b>PDIL</b>	<b>PROJECTS &amp; DEVELOPMENT INDIA LIMITED</b>	PC-183 / E / 8001 /S-V	0	 <b>Talcher</b> <b>Fertilizers</b>
		DOC. NO.	REV.	
		Page 1 of 31		



## SECTION-V

### SPECIAL CONDITIONS OF CONTRACT

	<b>ELECTRICAL WORKS (SUPPLY &amp; ERECTION) FOR ALTERNATE POWER SUPPLY ARRANGEMENT OF VIKARMPUR GUEST HOUSE AT TALCHER FERTILIZERS LTD., ANGUL, ODISHA SPECIAL CONDITIONS OF CONTRACT</b>	PC-183 / E / 8001/S-V	0	
		DOC. NO.	REV.	
		Page 2 of 31		

## TABLE OF CONTENTS

<b>1.0 INTRODUCTION:</b>	<b>4</b>
<b>2.0 LOCATION OF THE PROJECT SITE</b>	<b>4</b>
<b>3.0 GENERAL</b>	<b>4</b>
<b>4.0 GENERAL PROVISION WITH REGARD TO MATERIALS</b>	<b>5</b>
<b>5.0 OWNER'S OBLIGATIONS:</b>	<b>8</b>
<b>6.0 POWER &amp; WATER FOR CONSTRUCTION AND OTHER PURPOSES</b>	<b>8</b>
<b>7.0 RATES</b>	<b>8</b>
<b>8.0 SPECIFICATIONS</b>	<b>9</b>
<b>9.0 GATE PASSES</b>	<b>9</b>
<b>10.0 TIME SCHEDULE</b>	<b>9</b>
<b>11.0 ISSUE OF WORKING DRAWINGS</b>	<b>10</b>
<b>12.0 SERVING OF NOTICES</b>	<b>11</b>
<b>13.0 NOTHING EXTRA FOR ADVERSE SUB-SOIL CONDITION</b>	<b>11</b>
<b>14.0 CONTRACTOR'S RESPONSIBILITY FOR THE MANNER OF EXECUTION OF WORK</b>	<b>11</b>
<b>15.0 NO WORK SHALL BE UNDERTAKEN WITHOUT APPROVED WORKING DRAWINGS</b>	<b>11</b>
<b>16.0 CONTRACTOR SHALL KEEP FOUNDATION PITS/TRENCHES DRY</b>	<b>12</b>
<b>17.0 NOTHING EXTRA FOR INTRICATE CONCRETE SHUTTERING OR REINFORCEMENT WORK</b>	<b>12</b>
<b>18.0 NOTHING EXTRA FOR REBATING ETC.</b>	<b>12</b>
<b>19.0 CONSTRUCTION JOINTS</b>	<b>12</b>
<b>20.0 SUBMISSION OF BILL</b>	<b>12</b>
<b>21.0 CLAIMS BY THE CONTRACTOR</b>	<b>14</b>
<b>22.0 PROVISION FOR MULTIFARIOUS CHECKING OF WORK</b>	<b>14</b>
<b>23.0 DEFECT LIABILITY PERIOD</b>	<b>15</b>
<b>24.0 CLEARING, FILLING AND LEVELING OF SITE</b>	<b>15</b>
<b>25.0 CONTRACTOR TO COMPLY ALL LAWS</b>	<b>15</b>
<b>26.0 CONTRACTOR TO USE THE MATERIALS ONLY AFTER THE APPROVAL OF OWNER</b>	<b>15</b>
<b>27.0 COMPLIANCE OF ENTIRE PROVISIONS IS OBLIGATORY TO CONTRACTOR</b>	<b>15</b>
<b>28.0 DELIVERY AND DOCUMENTS</b>	<b>15</b>
<b>29.0 WEATHER CONDITIONS</b>	<b>15</b>
<b>30.0 INSTRUCTIONS, DIRECTIONS AND CORRESPONDENCE</b>	<b>16</b>
<b>31.0 QUALITY ASSURANCE / QUALITY CONTROL</b>	<b>16</b>
<b>32.0 HEALTH SAFETY AND ENVIRONMENT (HSE) MANAGEMENT</b>	<b>17</b>
<b>33.0 SUSPENSION OF WORKS</b>	<b>17</b>
<b>34.0 INCOMING MATERIAL REPORT/ INSPECTION</b>	<b>18</b>
<b>35.0 THIRD PARTY INSPECTION</b>	<b>18</b>
<b>36.0 SECURITIES OF MATERIALS / EQUIPMENTS</b>	<b>19</b>
<b>37.0 CONTRACTOR'S PERSONNEL AT SITE:</b>	<b>20</b>
<b>38.0 SETTING OUT THE WORKS</b>	<b>20</b>

	<b>ELECTRICAL WORKS (SUPPLY &amp; ERECTION) FOR ALTERNATE POWER SUPPLY ARRANGEMENT OF VIKARMPUR GUEST HOUSE AT TALCHER FERTILIZERS LTD., ANGUL, ODISHA SPECIAL CONDITIONS OF CONTRACT</b>	PC-183 / E / 8001/S-V	0	
		DOC. NO.	REV.	
		Page 3 of 31		

**39.0 COMPLIANCE WITH LABOUR/ INDUSTRIAL LAWS ..... 21**

**40.0 TERMS OF PAYMENT ..... 23**

**41.0 DISPATCH, TRANSPORTATION/SHIPPING ..... 26**

**42.0 WORK CONTRACT SERVICES ..... 26**

**43.0 CONSTRUCTION EQUIPMENT, TOOLS AND TACKLES DEPLOYMENT..... 29**



**44.0 BOCW (BUILDING AND OTHER CONSTRUCTION WORKS) ..... 29**

**45.0 COMPLIANCE TO DMI &SP (DOMESTICALLY MANUFACTURED IRON & STEEL PRODUCTS) POLICY ..... 30**

**46.0 SUB-CONTRACTOR/VENDOR AND MANUFACTURER WARRANTIES ..... 30**

**47.0 CONTRACTOR'S LIABILITY FOR APPROVED SUB CONTRACTOR : ..... 31**

---

	<b>ELECTRICAL WORKS (SUPPLY &amp; ERECTION) FOR ALTERNATE POWER SUPPLY ARRANGEMENT OF VIKARMPUR GUEST HOUSE AT TALCHER FERTILIZERS LTD., ANGUL, ODISHA SPECIAL CONDITIONS OF CONTRACT</b>	PC-183 / E / 8001/S-V	0	
		DOC. NO.	REV.	
		Page 4 of 31		

## SPECIAL CONDITIONS OF CONTRACT

### 1.0 INTRODUCTION:

- 1.1. Talcher Fertilizers Ltd. (TFL), hereinafter also referred to as "OWNER", A joint venture company of four major Public Sector Units – M/s. Gas Authority India Limited (GAIL), M/s. Rastriya Chemicals & Fertilizers Ltd. (RCF), M/s. Coal India Ltd. (CIL) and M/s. Fertilizers Corporation of India Ltd. (FCIL) has decided to build a world class Coal based fertilizer complex. The fertilizer complex is to be built at **Talcher, Angul District, Odisha (India)** and will consist of Coal Gasification Plant, Ammonia Plant and Urea Plant, along with Offsite and Utility Plants. Talcher Fertilizers Ltd. intend to invite quotations from eligible Contractors for **ELECTRICAL WORKS (SUPPLY & ERECTION) FOR ALTERNATE POWER SUPPLY ARRANGEMENT OF VIKARMPUR GUEST HOUSE AT TALCHER FERTILIZERS LTD., ANGUL, ODISHA**
- 1.2 Projects & Development India Ltd. (PDIL) has been retained as Consultant for providing Engineering Consultancy Services and Project Management Services for the aforesaid project.



### 2.0 LOCATION OF THE PROJECT SITE

A brief description of infrastructure at Talcher Fertilizer Plant Site is furnished below:

- The proposed project will be located within the premises of existing closed coal based Ammonia-Urea complex of FCI Ltd. Talcher Unit.
- The total land area of the site is 904.53 acres out of which lease hold land from Government of Odisha is 894.207 acres and land purchased from private parties is 10.33 acres.
- The area is not falling under coal bearing zone up to a depth of 200-250 meter.
- Talcher site is located at Vikrampur in Angul district of Odisha on the Cuttack-Sambalpur National Highway NH-42. NH-42 is passing at about 8 km from the site. The nearest railway station is Talcher at about 7 km from the site. Nearest air port Bhubaneswar is 150 km, 3 hours journey by road/ rail. Nearest sea port is Paradeep, 200 km by rail/road from the site. Talcher is situated at 21° 10" N Latitude and 82° 5" E Longitude.

### 3.0 GENERAL

- 3.1 Special Conditions of Contract shall be read in Conjunction with the General conditions of Contract, specification of work, Drawings and any other documents forming part of this Contract wherever the context so requires.
- 3.2 Notwithstanding the sub-division of the documents into these separate sections and volumes, every part of each shall be deemed to be supplementary to and complementary of every other part and shall be read with and into the Contract so far as it may be practicable to do so.
- 3.3 Where any portion of the General Condition of Contract is repugnant to or at variance with any provisions of the Special Conditions of Contract, unless a different intention

	<b>ELECTRICAL WORKS (SUPPLY &amp; ERECTION) FOR ALTERNATE POWER SUPPLY ARRANGEMENT OF VIKARMPUR GUEST HOUSE AT TALCHER FERTILIZERS LTD., ANGUL, ODISHA SPECIAL CONDITIONS OF CONTRACT</b>	PC-183 / E / 8001/S-V	0	
		DOC. NO.	REV.	
		Page 5 of 31		



appears, the provisions of the Special Conditions of Contract shall be deemed to override the provisions of the General Conditions of Contract and shall to the extent of such repugnancy, or variations, prevail.

- 3.4 Wherever it is mentioned in the specifications that the Contractor shall perform certain work or provide certain facilities, it is understood that the Contractor shall do so at his cost and the value of contract shall be deemed to have included cost of such performance and provisions, so mentioned.
- 3.5 The materials, design, and workmanship shall satisfy the relevant Indian Standards and CPWD specifications, the Job Specifications contained herein and Codes referred to. Where the job specification stipulate requirements in addition to those contained in the standard codes and specifications, these additional requirements shall also be satisfied.
- 3.6 It will be the Contractor's responsibility to bring to the notice of Engineer-in-Charge any irreconcilable conflict in the contract documents before starting the work (s) or making the supply with reference which the conflict exists.
- 3.7 In the absence of any Specifications covering any material, design of work (s) the same shall be performed / supplies / executed in accordance with Standard Engineering Practice as per the instructions / directions of the Engineer-in-Charge, which will be binding on the Contractor.



#### **4.0 GENERAL PROVISION WITH REGARD TO MATERIALS**

- 4.1 The CONTRACTOR shall, within the scope of work, undertake the following activities and responsibilities with respect to and in addition and without prejudice to the activities and responsibilities under Clause 4.1 and associated clauses there under in respect of materials:
  - i) The CONTRACTOR shall in taking delivery, ensure compliance of any condition for delivery applicable to deliveries from the concerned authority or carrier, and shall be exclusively responsible to pay and bear any detention, demurrage or penalty or other charges payable by virtue of any delay or failure by the CONTRACTOR in lifting the materials or in observing any of the conditions aforesaid, and shall keep the OWNER indemnified from and against all consequences there of
  - ii) The CONTRACTOR shall maintain a day-to-day account of all materials indicating the daily receipt(s), consumption(s) and balance of each material and category thereof. Such account shall be in the format, if any, prescribed by the ENGINEER-IN-CHARGE and shall be supported by all documents necessary to verify the correctness of the entries in the account. Such account shall be maintained at the CONTRACTOR MANAGER's office and site(s) and shall be open for inspection and verification (by verification of documents in support of the entry as also by feasible verification of the stock) at all times by the ENGINEER-IN-CHARGE with authority at all times without obstruction to enter into or upon any godown or other place(s) or premise(s) where the materials or any part of them are lying or stored and to inspect the same himself and or through his representative(s).



	<b>ELECTRICAL WORKS (SUPPLY &amp; ERECTION) FOR ALTERNATE POWER SUPPLY ARRANGEMENT OF VIKARMPUR GUEST HOUSE AT TALCHER FERTILIZERS LTD., ANGUL, ODISHA SPECIAL CONDITIONS OF CONTRACT</b>	PC-183 / E / 8001/S-V	0	
		DOC. NO.	REV.	
		Page 6 of 31		



- iii) All materials shall be taken delivery of, held, stored and utilised by the CONTRACTOR as Trustee of the OWNER, and delivery of the material to the CONTRACTOR shall constitute an entrustment thereof to the CONTRACTOR, with the intent that any utilization, application or disposal thereof by the CONTRACTOR otherwise than for permanent incorporation in the contractual works in terms of the contract shall constitute a breach of trust by the CONTRACTOR.
- iv) The CONTRACTOR shall at all times be exclusively responsible for any and all losses, damages, deterioration, misuse, wastage, theft, or other application or misapplication or disposal of the materials or any of them contrary to the provisions hereof and shall keep the OWNER indemnified from and against the same and shall forthwith at its own cost and expenses replace any such material, lost, damaged, deteriorated, misused, wasted, stolen, applied, misapplied and/or disposed as aforesaid with other material of equivalent quality and quantity delivered to site at the CONTRACTOR's risks and costs in all respects.
- v) The CONTRACTOR shall take out, at his own cost and keep in force at all times, during transit, handling, storage, and erection upto completion in all respect of the work, policy (ies) with Insurance Company (ies) approved by the OWNER for the full replacement value of the materials at site against the risks specified in the CONTRACT. Such policies shall be in the joint names of the OWNER and the CONTRACTOR, with exclusive right in the OWNER to receive all monies due in respect of such policy (ies) and with right in the OWNER (but without obligation to do so) to take out and pay the premia for any such policy (ies) and deduct the premia and any other costs and expense in this behalf from the monies for the time being due or in future becoming due to the CONTRACTOR. In case of Insurance claim, the GST leviable on the transfer of the claim money from OWNER to CONTRACTOR shall be over and above the GST cap indicated in the CONTRACT and shall be borne by OWNER.
- vi) If the CONTRACTOR shall default in replacing at the job SITE, without any additional cost to the OWNER, any material lost, damaged, deteriorated, misused, wasted, short, stolen, misapplied or disposed of within the provisions hereof above, the CONTRACTOR shall be liable to pay to the OWNER the cost of such materials.
- a) Notwithstanding anything herein provided, the CONTRACTOR shall be and remain solely and exclusively liable to repair, restore or replace, as the case may be, the materials damaged or destroyed as a result of any act or omission, notwithstanding the existence or otherwise of any policy(ies) of insurance aforesaid, with the intent that any policy(ies) of insurance aforesaid taken out by the CONTRACTOR or by the OWNER, on default by the CONTRACTOR, shall not anyway absolve the CONTRACTOR from his full liability up to and until issue of the Preliminary Acceptance Certificate as provided for herein in respect of the works, the work(s) and all materials incorporated therein shall be and remain at the risks of the CONTRACTOR in all respects, including (but not limited to) accident, lightning, earth-quake, fire, storm, flood, tempest, riot, civil commotion and/or war or otherwise with respect to the materials, but shall constitute merely an additional security and not a substitution of liability.

	<b>ELECTRICAL WORKS (SUPPLY &amp; ERECTION) FOR ALTERNATE POWER SUPPLY ARRANGEMENT OF VIKARMPUR GUEST HOUSE AT TALCHER FERTILIZERS LTD., ANGUL, ODISHA SPECIAL CONDITIONS OF CONTRACT</b>	PC-183 / E / 8001/S-V	0	
		DOC. NO.	REV.	
		Page 7 of 31		

- b) It shall be the exclusive responsibility of the CONTRACTOR to lodge and pursue any or all claims in respect of the insurance aforesaid.
- c) The CONTRACTOR shall, as a condition to the certification of any Running Account Bill, satisfy the OWNER/ Engineer-In-Charge of the existence of one or more policy(ies) of insurance, covering the materials as specified herein. The policy(ies) of insurance aforesaid shall cover all insurable risks, including but not limited to, any loss or damage commencing from the supplier's ware house in handling, transit, storage and during erection, theft, pilferage, riot, civil commotion, force majeure (including earth quake, flood, storm, cyclone, tidal wave, lightening and other adverse weather conditions), accidents of kinds, fire, war risks and explosion.
- vii) If the CONTRACTOR shall default in replacing at the job site, free of any cost to the OWNER, any material lost, damaged, deteriorated, misused, wasted, short, stolen, misapplied or disposed of within the provisions hereof above, the CONTRACTOR shall be liable to pay to the OWNER the cost of such materials.

## 4.2 SUPPLY OF MATERIALS

- 4.2.1 The CONTRACTOR shall supply the materials required to be supplied within the Contractor's scope of supply for incorporation in the permanent works in accordance with and to meet the requirements in quality, quantity and other particulars of the descriptions, specifications, plans, drawings, designs and other documents applicable thereto, and the CONTRACTOR shall be deemed to have undertaken that all materials selected, procured and supplied by the CONTRACTOR within the scope of supply shall be of the best quality and workmanship and shall be capable of producing the designed desired results and to perform the designed and desired functions to meet the contractual requirements in all respects for the project.
- 4.2.2 The CONTRACTOR shall undertake and complete the supply of materials within the scope of supply to meet the scheduled progress and requirements of the WORK within the scope of work.
- 4.2.3 All materials shall be deemed to have been accepted only when the material is received at the project SITE and accepted by the ENGINEER-IN-CHARGE. Such acceptance shall however be subject to the terms and conditions of CONTRACT, including the right of rejection and/or replacement as elsewhere herein specified.
- 4.2.4 Without prejudice to any other terms of the contract, it is clarified that the mere agreement, acceptance or prescription of a Delivery or other Schedule containing an extended time of commencement or completion in respect of the entire delivery(ies) or any of them shall not anyway constitute an extension of time in a terms of the CONTRACT so as to bind the OWNER or relieve the CONTRACTOR of all or any of his liabilities under CONTRACT, nor shall constitute a promise on behalf of the OWNER or a waiver by the OWNER of any of its rights in terms of the contract relative to the performance of the CONTRACT within the time specified or otherwise, but shall be deemed only (at the most) to be a guidance to the CONTRACTOR for better organising his work on a recognition that the CONTRACTOR has failed to organise his supplies and/or make the same within the time specified in the Delivery Schedule.
- 4.2.5 If the CONTRACTOR fails to supply the materials in accordance with the dates in this behalf specified in the Delivery Schedule which has an impact on the critical path of the schedule, the CONTRACTOR shall provide the OWNER with a suitable plan to

	<b>ELECTRICAL WORKS (SUPPLY &amp; ERECTION) FOR ALTERNATE POWER SUPPLY ARRANGEMENT OF VIKARMPUR GUEST HOUSE AT TALCHER FERTILIZERS LTD., ANGUL, ODISHA SPECIAL CONDITIONS OF CONTRACT</b>	PC-183 / E / 8001/S-V	0	
		DOC. NO.	REV.	
		Page 8 of 31		

recover the delay, but without prejudice to any other rights, discount or remedy available to the OWNER in respect of such delay or failure.

#### 4.2.6 MAKE OF MATERIALS

- i) All equipment and materials to be supplied under this CONTRACT shall be from approved vendors as indicated in the Bidding Document or as otherwise approved by the ENGINEER-IN-CHARGE / OWNER.
- ii) Where the makes of materials are not indicated in the Bidding document, the CONTRACTOR shall furnish details of proposed makes and supplies and supply the same after obtaining the OWNER's/ ENGINEER-IN-CHARGE's approval.

#### 5.0 OWNER'S OBLIGATIONS:

The OWNER'S obligations are limited to the following:



- a) Handing over the site in sections/ stages progressively.
- b) Approval of Construction drawings supplied by the Contractor.
- c) Payment to the contractor for performance of work under the contract as per the terms and conditions specified therein.
- d) A piece of land for setting up temporary office, Godown, etc., if available.

#### 6.0 POWER & WATER FOR CONSTRUCTION AND OTHER PURPOSES

Availability of water & power at site is very limited. Contractor shall have to make his own arrangements for Construction work.

#### 7.0 RATES

- 7.1 OWNER shall pay to contractor the total rates quoted by them for the due and faithful performance of contractor's obligation under the contract. The rates quoted by the contractor in SOR shall remain fixed and firm and not subject to any escalation unless and otherwise specified in the tender.
- 7.2 The rates shall be deemed to allow for all minor extras and constructional details which are not specifically shown on drawings or given in the specifications but are essential in the opinion of the Owner/ Consultant to the execution of work to conform to good workmanship and sound engineering practice. The Owner / Consultant reserve the right to make any minor changes during the execution without any extra payment.
- 7.3 The Owner / Consultant decision to classify any item 'minor changes', 'minor extras' and 'constructional details' shall be final conclusive and binding on the Contractor.
- 7.4 Rates quoted shall include for payment of royalties for obtaining earth, morrum, sand, aggregates, stones, etc. Nothing extra shall be paid to the Contractor on this account.
- 7.5 Contractor shall be responsible for making all necessary approach roads to the sites of execution for taking his rigs, cranes & equipments. No extra claim in this regard shall be entertained.
- 7.6 Schedule of rates submitted by the Tenderer shall be the true copy of the schedule of rates enclosed with the tender documents

	<b>ELECTRICAL WORKS (SUPPLY &amp; ERECTION) FOR ALTERNATE POWER SUPPLY ARRANGEMENT OF VIKARMPUR GUEST HOUSE AT TALCHER FERTILIZERS LTD., ANGUL, ODISHA SPECIAL CONDITIONS OF CONTRACT</b>	PC-183 / E / 8001/S-V	0	
		DOC. NO.	REV.	
		Page 9 of 31		

- 7.7 The quantities and items of work given in the Schedule of Rates are tentative and approximate. The OWNER reserves the right to order variation of work during the currency of the contract of its original contract value within the stipulated variation as per clause no. 60.2 of GCC.

The contractor shall not be entitled to any increase whatsoever on the SOR rates on account of any variation in the quantities and/or omission/addition of items vis-à-vis the quantities mentioned in the “Schedule of Rates **(Section VII)**” as long as the contract value finally determined on the basis of the certified final quantities and the contract item rates is within the stipulated variation as per clause no. 60.2 of GCC.

## 8.0 SPECIFICATIONS

- 8.1 If specification for an item of work is not covered by CPWD/ BIS specifications or Technical Specifications, the same shall be decided by the Owner/ Consultant and shall be binding on the Contractor.
- 8.2 The Owner/ Consultant shall have the right to cause the Contractor to purchase and use such materials of particular make or from a particular source which may in his opinion be necessary for proper and reasonable compliance with the specifications and execution of work.
- 8.3 (a) As and when required by the Owner/ Consultant, the Contractor shall provide all facilities at site or at manufacture’s works or in approved laboratory for testing of materials and/or workmanship. All the expenditure in respect of this shall be borne by the Contractor. The Contractor shall, when required to do so by the Owner/Consultant, confirm that the materials have been tested in accordance with requirements of the specifications.
- (b) Neither the omission by the Owner/ Consultant to test the materials nor the production of manufacturer(s) certificate, etc. shall affect the right of the Owner/Consultant to reject, after delivery, the materials found not in accordance with the specifications.

## 9.0 GATE PASSES



All tools, plant and materials shall be brought by the Contractor to the works site through a covering note to be submitted in 3 copies. One copy of the covering note will be delivered to the security staff and one copy to the Owner/Consultant. The third copy shall be retained by the Contractor. The Contractor shall follow all rules and regulations for entry / exit of their men and materials in/from project site as framed by Owner/Consultant.

## 10.0 TIME SCHEDULE

- 10.1 Bidder shall be required to complete the WORK under the CONTRACT so as to achieve the GUARANTEED COMPLETION DATE in accordance with the following:

<b>Completion Period/ Completion Schedule</b>	<b>03 (Three) Months from date of issuance of FOA (Fax of Acceptance)</b>
---	---

- 10.2 The basic consideration and essence of the Contract is the strict adherence to the Time schedules for performing the specified works as stipulated in the Contract.

	<b>ELECTRICAL WORKS (SUPPLY &amp; ERECTION) FOR ALTERNATE POWER SUPPLY ARRANGEMENT OF VIKARMPUR GUEST HOUSE AT TALCHER FERTILIZERS LTD., ANGUL, ODISHA SPECIAL CONDITIONS OF CONTRACT</b>	PC-183 / E / 8001/S-V	0	
		DOC. NO.	REV.	
		Page 10 of 31		

10.3 If at any time, the Owner/Consultant is of opinion that the Contractor has fallen behind the approved construction schedule, the Owner/ Consultant may, without any cost to Owner/ Consultant, require the Contractor to take such steps as may be necessary to improve his progress, especially require him to employ overtime operations, increase the number of shifts, work on holidays and Sundays or increase the capacity of his construction plant and equipment and require him to submit evidence demonstrating the manner in which the Contractor proposes to comply with the construction schedule. Failure of the Contractor to comply with the above will be considered a failure to execute the work with due diligence.

#### **10.4 Time schedule network/ bar chart.**

10.4.1 Together with the Work Order/ Contract confirmation, Contractor shall submit to Owner/ Consultant, his time schedule regarding the documentation, supply of materials as well as information about of his Subcontracts to be placed with their parties, including the dates on which Contractor intends to issue such Subcontracts.

10.4.2 The time schedule will be in the form of a network or a bar chart clearly indicating all main or key events regarding documentation, supply of materials, delivery and site fabrication, erection, inspection, testing and completion.

10.4.3 The original issue and subsequent revisions of Contractor's time schedule and or Sub-contractor's time schedules shall be sent to Consultant in two copies (of which one shall be in Soft copy) and two copies to Owner.

10.4.4 The time schedule network/bar chart shall be updated at least every fortnight.

#### **10.5 Progress Trend Chart/ Monthly Report**

10.5.1 Contractor shall report weekly to Owner/ Consultant the progress of the execution of Work Order/ Contract and achievement of targets set out in time bar chart.

10.5.2 The progress will be expressed in percentages shown in the progress trend chart.

10.5.3 The first issue of the progress trend chart will be forwarded together with the time bar chart along with the Work Order confirmation.



10.5.4 The fortnightly reporting will bear the updating of the progress trend chart.

10.5.5 All reports shall be submitted through e-mail. Monthly reports to be also submitted in hard copy.

#### **11.0 ISSUE OF WORKING DRAWINGS**

All Working drawings shall be issued by OWNER/ CONSULTANT's to the CONTRACTOR. Working drawings submitted by the OWNER/ CONSULTANT's progressively during the pendency of the contract, shall be approved/ marked "Good for execution/ construction" by Owner/ Consultant. The Contractor on this account shall not be entitled to put forth any claim whatsoever on account of delay in approval of the drawings to the Owner/ Consultant. Fabrication drawing, if any shall be prepared by the contractor itself and same shall be approved by OWNER/ CONSULTANT's.



	<b>ELECTRICAL WORKS (SUPPLY &amp; ERECTION) FOR ALTERNATE POWER SUPPLY ARRANGEMENT OF VIKARPUR GUEST HOUSE AT TALCHER FERTILIZERS LTD., ANGUL, ODISHA SPECIAL CONDITIONS OF CONTRACT</b>	PC-183 / E / 8001/S-V	0	
		DOC. NO.	REV.	
		Page 11 of 31		

## 12.0 SERVING OF NOTICES

The Contractor shall furnish to the Owner/ Consultant the name, designation and address of his authorized Agent for the purpose of serving of notice(s) regarding all complaints, communications and references and shall be deemed to have been duly given to the Contractor if delivered to the Contractor or his authorized agent or left at or posted to the address so given and shall be deemed to have reached such address in the ordinary course of post or on the day on which they were so delivered or left. In the case of contract by partnership firm, any change in the constitution of the firm shall be forthwith informed by the Contractor to the Owner/ Consultant.

- All correspondence from the CONTRACTOR to the OWNER shall be as per the correspondence distribution schedule. All communications including technical-commercial clarifications and/ or comments shall be addressed to OWNER/CONSULTANT and shall always bear reference of DLOA number.
- Correspondence on technical and commercial matters shall be dealt with in separate letters and each copy of the letter shall be complete with all Annexures, if any.
- Any notice to the CONTRACTOR under the terms of the CONTRACT shall be served by registered e-mail/Speed Post, fax or courier.
- Any notice to the OWNER shall be served from the CONTRACTOR's Principal office in the same manner.
- Any written order or instruction of OWNER or his duly authorised representative, communicated to authorised representative of the CONTRACTOR at site office shall be deemed to have been communicated to the CONTRACTOR at his legal address.

## 13.0 NOTHING EXTRA FOR ADVERSE SUB-SOIL CONDITION



There may be variation in nature of sub-soil both horizontally and vertically. The Contractor shall have to take necessary precaution during excavation against any happening like collapsing of sides etc. Any slip or fall in excavation shall have to be cleared by the Contractor at his own cost. In case of excessive heaving, it shall have to be cut and refilled with lean concrete by the Contractor at his own cost. The Contractor shall have to adopt underwater work in case of occurrence of piping/quick conditions without any cost to Owner/Consultant.

## 14.0 CONTRACTOR'S RESPONSIBILITY FOR THE MANNER OF EXECUTION OF WORK

The Contractor shall be responsible for the manner and the method of executing the work. The work shall be subject to the approval of Owner/ Consultant from time to time for purposes of determination of the question whether the work is executed by the Contractor in accordance with the contract.

## 15.0 NO WORK SHALL BE UNDERTAKEN WITHOUT APPROVED WORKING DRAWINGS

No work shall be undertaken at Site by the Contractor until detailed approved working drawings are marked "Good for execution/ construction" by Owner/ Consultant. Any work done without the aforesaid approved working drawing shall be at the Contractor's own risk and costs.

	<b>ELECTRICAL WORKS (SUPPLY &amp; ERECTION) FOR ALTERNATE POWER SUPPLY ARRANGEMENT OF VIKARPUR GUEST HOUSE AT TALCHER FERTILIZERS LTD., ANGUL, ODISHA SPECIAL CONDITIONS OF CONTRACT</b>	PC-183 / E / 8001/S-V	0	
		DOC. NO.	REV.	
		Page 12 of 31		

## 16.0 CONTRACTOR SHALL KEEP FOUNDATION PITS/TRENCHES DRY

The Contractor, during the pendency of contract, shall keep in dry condition of pits, trenches, which are not yet back filled due to technical reasons, if not shall be Bail-out/Pump-out all accumulation at his own cost for the safety of the structure / element. During pumping, the Contractor shall have to ensure that 'Loss of Ground' does not occur. Other approved methods shall be undertaken by the Contractor to avoid 'Loss of Ground' if occurred, at his own cost.

## 17.0 NOTHING EXTRA FOR INTRICATE CONCRETE SHUTTERING OR REINFORCEMENT WORK

Nothing extra shall be paid for any intricate concrete, shuttering or reinforcement work for foundations of equipment and machinery and for other foundation/superstructure works or for any delay inherent in concreting in small and thin sections in concrete or RCC works etc.

## 18.0 NOTHING EXTRA FOR REBATING ETC.

Nothing extra shall be paid in concrete/RCC works for all rebating, chamfering, grooving, sinking, trotting weathering, moulding, etc. to accord with the details shown on the working drawings.

## 19.0 CONSTRUCTION JOINTS

19.1 In case of execution of massive concrete elements both in foundation and in superstructure and in some other locations as would be permitted except where specified in the working drawings, the work shall be carried out in one single operation without any break in concreting within time limit that would be specified by the Owner / Consultant without any additional cost to Owner/ Consultant.

19.2 All specified construction joints, either horizontal or vertical, in any element of concrete member shall be provided with shear keys of such dimensions as would be determined by the Owner/Consultant. Before adopting the next operation for the other half of the element these shear keys along with the entire surface of the joint shall be roughened and deepened to above 20 mm by chipping, washing and cleaning thoroughly. The Contractor shall provide cement slurry in sufficient quantity over the cleaned surface for proper bond as per the direction of Owner/Consultant. The Contractor shall not be entitled to any extra/payment; on this account.



## 20.0 SUBMISSION OF BILL

Contractor is to submit the bills and record of measurements in three (3) copies for works executed by him.

### 20.1 FOR R/A BILLS:

Contractor is to submit the bills and record of measurements to EIC complete in all respect for certification by Owner/Consultant in three copies for works executed by him progressively.



	<b>ELECTRICAL WORKS (SUPPLY &amp; ERECTION) FOR ALTERNATE POWER SUPPLY ARRANGEMENT OF VIKARMPUR GUEST HOUSE AT TALCHER FERTILIZERS LTD., ANGUL, ODISHA SPECIAL CONDITIONS OF CONTRACT</b>	PC-183 / E / 8001/S-V	0	
		DOC. NO.	REV.	
		Page 13 of 31		

## 20.2 MEASUREMENT OF WORKS

In addition to the provisions of relevant Clause of GCC, following shall also apply:

Measurement of work shall be made in the units mentioned in the schedule of rates. The abbreviations used in the schedule of rates are mentioned in Schedule of Rates.

The Engineer-in-Charge shall, except as otherwise stated ascertain and determine by measurement the value of Work done, in accordance with the Contract and as per actual Work done. The Engineer-in-Charge shall, when he requires any part or parts of the Works to be measured, give notices to the Contractor's authorized agent or representative who shall forthwith attend or send a qualified agent to assist the Engineer-in-Charge in making such measurement and shall furnish all particulars required by either of them. Should the Contractor not attend or neglect or omit to send such representative then the measurement made by the Engineer-in-Charge shall be taken to be the correct measurement of the Work. For all measurements, figured dimensions given in the drawings shall be followed. Measurement of all hidden items shall be carried out by the Engineer-in-Charge. The Contractor or his representative who attends may at the time of measurement take such notes and measurements as he may desire.

The measurements for excavations shall be restricted and limited to minimum excavation line as per drawing for payment purposes.

## 20.3 DISPUTE IN MODE OF MEASUREMENT



Where Works have to be measured for any purpose whatsoever, it shall be in accordance with item specifications as per relevant Indian Standards unless otherwise specifically indicated in the Contract Specifications. All measurements will be recorded in metric units only. In case of absence of mode of measurement of any item not covered by both the methods mentioned above, the Engineer-in-Charge's decision shall be final and binding. The required number of bills, registers, bill forms, level/field books, materials/ account registers, testing registers, site order books and any other stationary item pertaining to this contract shall be printed and provided for by the contractor, at his own cost in the format prescribed and approved by the Engineer-in-Charge in writing. The Measurement Sheet will have three copies in different colour pages and will be printed so that proper referring and record of complete measurement is maintained. Original sheet will be retained in the book and will be returned to Owner on completion of Work.

## 20.4 SUBMISSION OF FINAL BILL

The final bill complete in all respect shall be submitted after certified completion of work.

20.4.1 On the basis of the rates provided in the CONTRACT and subsequent Change Order(s)/Amendment(s), if any, the CONTRACTOR shall prepare the Final Bill as per GST norms. Additions claimed on account of CHANGE ORDER(s) shall be separately indicated in the Final Bill with reference to the relative CHANGE ORDERS(s).

20.4.2 The Final Bill shall, in addition to the payment entitlements arrived at according to the provisions of Clause 20.4.1 hereof shall separately state and include therein all claims of

	<b>ELECTRICAL WORKS (SUPPLY &amp; ERECTION) FOR ALTERNATE POWER SUPPLY ARRANGEMENT OF VIKARMPUR GUEST HOUSE AT TALCHER FERTILIZERS LTD., ANGUL, ODISHA SPECIAL CONDITIONS OF CONTRACT</b>	PC-183 / E / 8001/S-V	0	
		DOC. NO.	REV.	
		Page 14 of 31		

the CONTRACTOR, if any, with full particulars of the nature of such claim and grounds on which it is based and the amount claimed.

20.4.3 The Final Bill drawn in accordance with Clause 20.4.1 shall be submitted (together with the COMPLETION CERTIFICATE along with other documents as stipulated at Clause No. 39.8 of SCC, to the ENGINEER-IN-CHARGE for certification, who shall certify the Final Bill, if drawn in accordance with Clause 20.4.1. After certification of the ENGINEER-IN-CHARGE, the Final Bill shall be submitted in quadruplicate (or in such other number of copies as the OWNER may prescribe) to the OWNER for payment.

20.4.4 All monies payable under the CONTRACT for WORKS to be performed and MATERIALS to be supplied up to and including successful completion shall become due and payable to the CONTRACTOR only after submission to the OWNER of the Final Bill prepared in accordance with the provisions of Clause 20.4.1 hereof and associated provisions there under accompanied by the COMPLETION CERTIFICATE in respect of the WORKS.

20.4.5 Payments of the amount(s) due on the Final Bill to the extent certified by the ENGINEER-IN-CHARGE, shall be made within 30 (Thirty) days from the due date as specified in Clause 20.4.4 hereof, subject to the deductions provided in Clause 20.4.5.1.

20.4.5.1 All payments due to the CONTRACTOR on the Final Bill shall be subject to tax deductions and any other deductions provided in the CONTRACT or required to be made under any law, rule or regulation having the force of law for the time being applicable, or elsewhere provided for in the CONTRACT documents.



## 21.0 CLAIMS BY THE CONTRACTOR

21.1 No claim(s) shall on any account be made by the CONTRACTOR after submission of the Final Bill, with the intent that the Final Bill prepared by the CONTRACTOR shall reflect any and all claims whatsoever of the CONTRACTOR against the OWNER arising out of or in connection with the CONTRACT or any supply made or work performed by the CONTRACTOR there under or in relation thereto, and notwithstanding any enabling provision in any law or CONTRACT and notwithstanding any claim that the CONTRACTOR could have with respect thereto, the CONTRACTOR hereby waives and relinquishes any and all such claims not included in the Final Bill and absolves and discharges the OWNER from and against the same, even if in not including the same as aforesaid, the CONTRACTOR shall have acted under a mistake of law or of fact, or shall claim to have acted under economic compulsion or necessity.

21.2 If required by the OWNER, the ENGINEER-IN-CHARGE shall be authorised to require the CONTRACTOR to furnish, and the CONTRACTOR shall, upon the request of the ENGINEER-IN-CHARGE /OWNER, furnish all invoices, vouchers and accounting records as may be deemed necessary by the ENGINEER-IN-CHARGE /OWNER for the purpose of verifying any CONTRACTOR's claim.

## 22.0 PROVISION FOR MULTIFARIOUS CHECKING OF WORK

Before commencement of the actual concreting operation the position and layout of foundations, pedestals, inserts, pockets, recess, reinforcement and form work shall be checked repeatedly by Owner/Consultant. No claim whatsoever shall be entertained on this account. The level of foundations shall be accurately maintained as shown in the drawings or as directed by the Owner/Consultant. No padding, plastering or chipping shall be allowed for achieving the results.

	<b>ELECTRICAL WORKS (SUPPLY &amp; ERECTION) FOR ALTERNATE POWER SUPPLY ARRANGEMENT OF VIKARMPUR GUEST HOUSE AT TALCHER FERTILIZERS LTD., ANGUL, ODISHA SPECIAL CONDITIONS OF CONTRACT</b>	PC-183 / E / 8001/S-V	0	
		DOC. NO.	REV.	
		Page 15 of 31		

### 23.0 DEFECT LIABILITY PERIOD

Defect Liability Period shall be 12 months from the date of completion of works in all respects as declared by EIC.

### 24.0 CLEARING, FILLING AND LEVELING OF SITE

The site shown on the layout plan shall be cleared by the Contractor of all obstructions, loose stones, materials, rubbish of all kinds of bushes, trees, grass as well as brush wood. All holes/hollow, whether originally existing or produced by removal of loose stones or brush wood, shall be carefully filled up with earth, well rammed and levelled off as directed by the Owner/ Consultant. The Contractor will not be entitled to any payment in his regard.

### 25.0 CONTRACTOR TO COMPLY ALL LAWS

25.1 The contract shall be governed by the law in force in the Republic of India.

25.2 The Contractor shall comply with all laws etc. The Contractor shall be responsible to secure compliance with the Central and States Laws as well as the Rules, Regulations, by-laws and orders of the legal authorities and statutory bodies which are in force or as may be in force from time to time. He shall give to the Municipal Corporation Committees, police and other relevant authorities all such notices, etc. as may be required by law and obtain all requisite license for temporary constructions, enclosures, etc. and pay all fees, taxes and such other dues or charges which may be leviable on account of any of his operations in executing the works under this contract. Owner/Consultant shall not pay anything extra to the Contractor on this account. The Contractor shall also make good at his own cost, any damage done by him to any adjoining property, during execution of work.

### 26.0 CONTRACTOR TO USE THE MATERIALS ONLY AFTER THE APPROVAL OF OWNER

The Contractor shall use the materials only after the approval of Owner/ Consultant, before incorporation of the same in the works.

### 27.0 COMPLIANCE OF ENTIRE PROVISIONS IS OBLIGATORY TO CONTRACTOR



It shall always prevail, unless otherwise specifically stated, that the entire provisions of the Tender Document have been accepted for compliance by the Contractor without any reservation.

### 28.0 DELIVERY AND DOCUMENTS

Delivery of the Goods shall be made by the Contractor in accordance with the terms specified by the Owner/Consultant in the schedule of requirements in Technical Specifications and the special conditions of Contract.

### 29.0 WEATHER CONDITIONS

Owner/Consultant may order Contractor to suspend any work which in the opinion of Owner/Consultant may be subject to damage by prevailing weather conditions. No claim whatsoever on this account shall be entertained.

	<b>ELECTRICAL WORKS (SUPPLY &amp; ERECTION) FOR ALTERNATE POWER SUPPLY ARRANGEMENT OF VIKARMPUR GUEST HOUSE AT TALCHER FERTILIZERS LTD., ANGUL, ODISHA SPECIAL CONDITIONS OF CONTRACT</b>	PC-183 / E / 8001/S-V	0	
		DOC. NO.	REV.	
		Page 16 of 31		

It is presumed that the Contractor has familiarized himself with the weather conditions prevailing in the area therefore in such weather parameters if it appears to the Engineer –in –charge (EIC) that certain weather condition may damage the work or specified quality of the work can be achieved without stoppage of the work, the EIC in such conditions may require the Contractor to stop the work till such time as he thinks fit and appropriate. It is understood by the contractor that no compensation will be admissible on this count.

### **30.0 INSTRUCTIONS, DIRECTIONS AND CORRESPONDENCE**

30.1 The work described in Contract is to be executed according to the standards, data sheets, tables, Specifications and Drawings and according to all conditions both general and specific enclosed with the Tender document, unless any or all of them shall have been modified or cancelled in writing as a whole or in part.

- i) All instructions and orders to Contractor shall, except what is herein provided, given by Owner/Consultant.
- ii) All the work shall be carried out under the direction of and to the satisfaction of Owner/Consultant.
- iii) All communications including technical/commercial clarifications and/or comments shall bear reference to the DLOA/ Contract.
- iv) Invoice for payment against DLOA/ Contract shall be addressed to Owner/ Consultant.
- v) The DLOA number shall be shown on all invoices, communications, packing lists, containers and bills of lading etc.

30.2 Correspondence on technical and commercial matters shall be dealt with in separate letters and each copy of the letter shall be complete with all Annexures. Wherever possible, correspondence should be through e-mails.



30.3 Correspondence for expediting and Third Party Inspection (TPI), if applicable, shall be done directly with inspector with a copy to consultant & owner.

### **31.0 QUALITY ASSURANCE / QUALITY CONTROL**

31.1 After the award of the contract detailed quality assurance programme shall be prepared by the Contractor for the execution of contract for various works which will be mutually discussed and agreed to.

31.2 The Contractor shall establish document and maintain an effective quality assurance system outlined in recognized codes.

31.3 Quality Assurance System plans/procedures of the Contractor shall be furnished in the form of a QA manual after award of job. This document should cover details of the personnel responsible for the Quality Assurance, plans or procedures to be followed for quality control in respect of Design, Engineering, Procurement, Supply, Installation, Testing and completion in all respect till final acceptance by Owner. The quality assurance

	<b>ELECTRICAL WORKS (SUPPLY &amp; ERECTION) FOR ALTERNATE POWER SUPPLY ARRANGEMENT OF VIKARMPUR GUEST HOUSE AT TALCHER FERTILIZERS LTD., ANGUL, ODISHA SPECIAL CONDITIONS OF CONTRACT</b>	PC-183 / E / 8001/S-V	0	
		DOC. NO.	REV.	
		Page 17 of 31		

system should indicate organizational approach for quality control and quality assurance of the construction activities, at all stages of work at site.

- 31.4 The Owner/ Consultant or their representative shall reserve the right to inspect/ witness, review any or all stages of work at shop/site as deemed necessary for quality assurance.
- 31.5 The Contractor has to ensure the deployment of quality Assurance and Quality Control Engineer(s) depending upon the quantum of work.  
This QA/QC group shall be fully responsible to carry out the work as per standards and all code requirements. In case Engineer-in-charge feels that Contractor's QA/QC Engineer(s) are incompetent or insufficient, Contractor has to deploy other experienced Engineer(s) as per site requirement and to the full satisfaction of Engineer-In-Charge.
- 31.6 In case Contractor fails to follow the instructions of Engineer-in-charge with respect to above clauses, next payment due to him shall not be released unless until he complies with the instructions to the full satisfaction of Engineer-in-charge.
- 31.7 The Contractor shall adhere to the approved quality assurance system



### **32.0 HEALTH SAFETY AND ENVIRONMENT (HSE) MANAGEMENT**

The Contractor, during entire duration of the Contract, shall adhere to HSE requirement as per Specification enclosed in the Bidding Document as per **Annexure - I (Annexure to Special Conditions of Contract)**

### **33.0 SUSPENSION OF WORKS**

- 33.1 The OWNER reserves the right to suspend and reinstate execution of the whole or any part of the WORK without invalidating the provisions of the CONTRACT. Orders for suspension or reinstatement of the WORKS will be issued by the OWNER to the CONTRACTOR in writing. The time for completion of the WORKS will be extended for a period equal to the duration of the suspension along with mutually agreed remobilization period.
- 33.2 If such suspension of WORK by OWNER delays or is likely to delay the progress of WORK or the carrying out of WORK under CONTRACT resulting in additional expenses or increased liability to CONTRACTOR, the OWNER shall pay to the CONTRACTOR all reasonable expenses, mutually agreed between OWNER and CONTRACTOR, arising from suspension of the work by an order in writing of the OWNER provided that such suspensions of work is more than a cumulative period of Sixty days (60) days and provided that such suspension is not due to some fault on the part of the CONTRACTOR or a SUB-CONTRACTOR.
- 33.3 If the OWNER has;
- (i) failed to pay the CONTRACTOR any sum due under the CONTRACT within the period specified in the Contract; or
  - (ii) failed to approve invoice or supporting document without just cause within the period specified in the Contract; or
  - (iii) committed substantial breach of the Contract:

Then, CONTRACTOR may give a notice requesting OWNER to remedy aforesaid default within 30 days. If OWNER fails to remedy it within the said period,

	<b>ELECTRICAL WORKS (SUPPLY &amp; ERECTION) FOR ALTERNATE POWER SUPPLY ARRANGEMENT OF VIKARMPUR GUEST HOUSE AT TALCHER FERTILIZERS LTD., ANGUL, ODISHA SPECIAL CONDITIONS OF CONTRACT</b>	PC-183 / E / 8001/S-V	0	
		DOC. NO.	REV.	
		Page 18 of 31		

CONTRACTOR may suspend the performance of its obligations under the CONTRACT.

33.4 If the CONTRACTOR's performance of its obligations is suspended under the CONTRACT pursuant to clause 33.3 as above, then the COMPLETION TIME shall be extended and all reasonable additional costs or expenses incurred by the CONTRACTOR and mutually agreed between OWNER and CONTRACTOR, as a result of such suspension shall be paid by the OWNER to the CONTRACTOR provided that such suspension is not due to fault on the part of CONTRACTOR or its SUB CONTRACTOR.

#### 34.0 INCOMING MATERIAL REPORT/ INSPECTION



All material entering the site shall be properly recorded by contractor's representative with detail of challan, bill and quantity.

- a) All equipment shall be inspected and tested as per an agreed Quality Assurance Plan before the same is packed and dispatched from the Contractor's/ Vendor's Works. The Contractor shall carry out tests as specified/ directed by Engineer.
- b) Contractor shall perform all such tests as may be necessary to meet requirements of Local Authorities, Municipal or other statutory laws/ bye-laws in force. No extra shall be paid for these.
- c) The OWNER/ CONSULTANT may, at his sole discretion, carry out inspection at different stages during manufacturing and final testing after manufacturing.
- d) Approvals or passing of any inspection by the OWNER/ CONSULTANT or his authorized representative shall not however, prejudice the right of the OWNER/ CONSULTANT to reject the plan if it does not comply with the specification when erected or give complete satisfaction in service.
- e) All materials and equipment found defective shall be replaced and the whole work again tested to meet the requirements of the specifications, at the cost of the contractor. Contractor has to obtain a performance certificate/approval for the complete layout of piping/equipment erected.

#### 35.0 THIRD PART INSPECTION

- i. A Third Party Inspection Agency (TPIA), shall be engaged to carryout inspection of equipment/ materials at manufacturer/ supplier works, prior to dispatch, unless the TPI is explicitly waived off (in writing) by the OWNER/ CONSULTANT.
- ii. The TPI shall be carried out by any of the below mentioned approved agencies only:
  - Bureau Veritas (Ind.) Pvt. Ltd. (BVIS)
  - Lloyd's Register (LRIS)
  - Indian Register of Shipping (IRS)/
  - DNV GL
  - TUV India Pvt. Ltd. (TUV)



	<b>ELECTRICAL WORKS (SUPPLY &amp; ERECTION) FOR ALTERNATE POWER SUPPLY ARRANGEMENT OF VIKARMPUR GUEST HOUSE AT TALCHER FERTILIZERS LTD., ANGUL, ODISHA SPECIAL CONDITIONS OF CONTRACT</b>	PC-183 / E / 8001/S-V	0	
		DOC. NO.	REV.	
		Page 19 of 31		

- iii. Third Party Inspection Release Note clearly indicating that material has been inspected and accepted as per QAP approved by OWNER shall be submitted for OWNER/ CONSULTANT review prior to dispatch.
- iv. Approvals or passing of any inspection by the TPIA shall not however, prejudice the right of the OWNER/ CONSULTANT to reject the plan if it does not comply with the specification when erected or give complete satisfaction in service.
- v. The entire Cost for engagement of TPIA and the necessary modification/ rectifications (if any) prior to dispatch, shall be borne by the Contractor and no extra claim whatsoever shall be admissible on this account.
- vi. The OWNER/ CONSULTANT's Engineer may, at his sole discretion, carry out inspection at different stages during manufacturing and final testing after manufacturing. Testing performed in the presence of the Purchaser's representatives shall not relieve the supplier of their own responsibilities and guarantees and any other contractual obligations.

### 36.0 SECURITIES OF MATERIALS / EQUIPMENTS



Contractor shall be solely responsible for the security of the material at site and TFL/ Consultant shall not be responsible for any loss/theft of the materials.

- a) Materials required for the works, whether brought by the Contractor shall be stored by the Contractor only at places approved by the Engineer-in-Charge, as storage and safe custody of material shall be responsibility of the Contractor.
- b) TFL,'s officials concerned with the Contract shall be entitled at any time to inspect and examine any materials intended to be used in or on the works, either on the site or at factory or workshop or other place(s) where such materials are assembled, fabricated, manufactured or at any place(s) where these are lying or from which these are being obtained and the Contractor shall give such facilities as may be required for such inspection and examination.
- c) The contractor shall be the OWNER of all bought out items and materials and shall be responsible for the safety, security, insurance and care and custody of all the materials lying at site. TFL will have lien on all the items including those brought by the contractor for the purpose of Erection, testing, and commissioning of the work. For all Equipments/Materials, the title of Ownership shall pass on to the OWNER at the time of acceptance of entire work.

However, in case of termination of contract the transfer of title shall pass automatically to OWNER.

- d) CONSTRUCTION EQUIPMENT used by the CONTRACTOR and its SUB-CONTRACTORS in connection with the execution of works shall remain the property of CONTRACTOR or its SUB-CONTRACTORS. All duties, levies, taxes etc. payable on account of



	<b>ELECTRICAL WORKS (SUPPLY &amp; ERECTION) FOR ALTERNATE POWER SUPPLY ARRANGEMENT OF VIKARMPUR GUEST HOUSE AT TALCHER FERTILIZERS LTD., ANGUL, ODISHA SPECIAL CONDITIONS OF CONTRACT</b>	PC-183 / E / 8001/S-V	0	
		DOC. NO.	REV.	
		Page 20 of 31		

CONSTRUCTION EQUIPMENT shall be borne by the CONTRACTOR. CONTRACTOR shall indemnify the OWNER on this count.

### 37.0 CONTRACTOR'S PERSONNEL AT SITE:

List of persons employed by Contractor for the subject work mentioning their residential address shall be submitted to TFL. In case of any revision, the same shall be informed to TFL from time-to-time. If required necessary verification from Police / Gram Pradhan shall have to be submitted by the contractor.

The Contractor shall be directly responsible for any/all disputes arising between him and his personnel and keep indemnified against all losses, damage and claims arising thereof.

Within the TFL's premises, the Contractor's personnel shall not do any private work other than their normal duties.

The personnel engaged by the Contractor shall be subject to security check by the TFL's security staff while entering/leaving the premises. The contractor & his personnel shall be required to follow the rules and regulations of TFL in force from time-to-time. The contractor may also be required to provide photo passes to the personnel required by him, for security and safety reasons and furnished the details of the same when asked for.

No other person except Contractor's authorized representative shall be allowed to enter TFL premises Contractor shall also not entertain any outsider or extend any service beyond TFL's premises. Entry of Contractor's persons shall be regulated with proper identity/gate pass.

Contractor shall be fully responsible for theft, burglary, fire or any mischievous deeds by his staff and any loss to TFL shall be recovered from the immediate bill of the Contractor.



Contractor shall provide all necessary tools and tackles, equipments, safety belt, wheel burrow, scaffolding, ladders, drilling m/c & safety equipment etc. required to carry out job at his cost and material used by Contractor shall be of standard make and approval of Engineer-In-Charge shall be taken for the same.

TFL also reserves the right to ask the Contractor to remove particular person(s) from site with immediate effect if in the opinion of TFL, his behaviour/ performance is not up to the mark and/or found indulging in unlawful activities, Contractor shall immediately comply with such instructions.

It will be the responsibility of contractor's engineer to ensure that their personnel behave in a proper manners and behaviour and not to undergo the argument with the employees. It will be the responsibility of the Contractor's Engineer to deal with such complaints or co-ordinate with the TFL Engineer.

### 38.0 SETTING OUT THE WORKS

The CONTRACTOR shall supply dimensioned drawings, levels and other information necessary to set out the works and the Contractor shall set out the works and be



	<b>ELECTRICAL WORKS (SUPPLY &amp; ERECTION) FOR ALTERNATE POWER SUPPLY ARRANGEMENT OF VIKARPUR GUEST HOUSE AT TALCHER FERTILIZERS LTD., ANGUL, ODISHA SPECIAL CONDITIONS OF CONTRACT</b>	PC-183 / E / 8001/S-V	0	
		DOC. NO.	REV.	
		Page 21 of 31		

responsible for the accuracy of the same. He shall rectify at his own cost and to the satisfaction of the Engineer-in-Charge any error found at any stage which may arise through in accurate setting out. The Contractor shall protect and preserve all bench marks used in setting out the works till end of the Defects Liability Period unless the Engineer-in-Charge direct their earlier removal.

### 39.0 COMPLIANCE WITH LABOUR/ INDUSTRIAL LAWS



RESPONSIBILITIES OF THE CONTRACTOR AND COMPLIANCE WITH LABOUR/ INDUSTRIAL LAWS:

- a. The contractor shall have his own PF code no. with the RPFC as required under Employee PF & Miscellaneous Provisions Act, 1952 and ESI code No. required under Employee State Insurance Act 1948 before commencement of work.
- b. The contractors shall periodically submit the challans / receipts / proof for the depositing PF contribution with RPFC and ESIC.
- c. The contractor is require to obtain labour license under the provisions of Contract Labour (R&A) Act, 1970 from the office of ALC (Central), Ministry of Labour, Govt. of India.
- d. The contractor is liable to abide by all necessary licenses / permissions from the concerned authorities as provided under the various labor legislations
- e. The contractor shall discharge obligations as provided under various statutory enactment including the employees Provident Fund and Miscellaneous Provisions Act, 1952, Contract Labour (R&A) Act, 1970, Minimum Wages Act, 1948, Payment of wages act 1936, Workman Compensation Act 1923, Employees' State Insurance Act 1948 and other relevant acts, rules and regulations enforced from time to time.
- f. The contractor shall be solely responsible for the payment of wages and other dues to the personnel, if any, deployed by him latest by 7<sup>th</sup> day of the subsequent month.
- g. The contractor shall be solely responsible and indemnify the TFL against all charges, dues, claim etc. arising out of the disputes relating to the dues and employment of personnel, if any, deployed by him.
- h. The contractor shall indemnify TFL against all losses or damages, if any, caused to it on account of acts of the personnel, if any, deployed by him.
- i. All personnel deployed by the contractor should be on the rolls of the contractor.
- j. The contractor shall ensure regular and effective supervision and control of the personnel, if any, deployed by him and gives suitable direction for undertaking the contractual obligations.
- k. The personnel to be deputed by the contractor shall observe all security, fire and safety rules of TFL while at the site. His Work/Services will be supervised by the supervisors of contractor. Contractor has to be strictly adhere to guidance, instruction when required.
- l. Contractor shall provide proper identification cards for his employees to be deputed by him for Work/Services, duly signed by the contractor or authorized person on behalf of

	<b>ELECTRICAL WORKS (SUPPLY &amp; ERECTION) FOR ALTERNATE POWER SUPPLY ARRANGEMENT OF VIKARMPUR GUEST HOUSE AT TALCHER FERTILIZERS LTD., ANGUL, ODISHA SPECIAL CONDITIONS OF CONTRACT</b>	PC-183 / E / 8001/S-V	0	
		DOC. NO.	REV.	
		Page 22 of 31		

contractor. Also the contractor should obtain entry passes from Security Dept. through OPERATION-IN-CHARGE for his employees.

- m. Contractor has to deploy the personnel with no past criminal records. Reformed people, names of such persons should be clearly indicated in case of. Also the contractor has to provide police verification for all the persons deployed by him.
- n. While confirming to any of these conditions, the contractor should ensure that no law of state regarding labour, their welfare, conduct etc, is violated. The contractor shall indemnify TFL for any action brought against him for violation, non-compliance of any act, rules & regulation of centre / state / local statutory authorities.
- o. All existing and amended safety / fire rules of TFL are to be followed at the work site.
- p. Contractor shall ensure payment of wages to the personnel employed and meet all statutory obligations of payment as per Minimum Wages act 1948 and payment of wages Act 1936.
- q. Special safety equipment e.g. safety belts, helmets, hand gloves, goggles, safety shoes etc shall be provided to the personnel engaged by the contractor.
- r. Suitable site office space may be provided by TFL if required and available.
- s. In case of accident, injury and death caused to the employee of the contractor while executing the Work under the contract, the contractor shall be solely responsible for payment of adequate compensation, insurance money etc. to the next kith & kin of injured / diseased. Contractor shall indemnify TFL from such liabilities.
- t. The contractor shall also undertake to obtain necessary group insurance coverage covering all risks connected with the job to be undertaken by him under the contract from insurance company and pay the premium accordingly.
- u. The contractor shall not employ or permit to be employed any person suffering from any contagious, loathsome or infectious disease. The contractor shall get examined his employees / persons deployed from a civil govt. doctor.
- v. No employees or person of contractor (including contractor) be allowed to consume alcoholic drinks or any narcotics within the plant premises. If found under the influence of above, the owner / TFL will terminate the contract immediately and may refer the case to police.
- w. The contractor hereby agrees to indemnify owner/ TFL and harmless from all claims, demands, actions, cost and charges etc brought by any court, competent authority/ statutory authorities against owner/ TFL.

	<b>ELECTRICAL WORKS (SUPPLY &amp; ERECTION) FOR ALTERNATE POWER SUPPLY ARRANGEMENT OF VIKARMPUR GUEST HOUSE AT TALCHER FERTILIZERS LTD., ANGUL, ODISHA SPECIAL CONDITIONS OF CONTRACT</b>	PC-183 / E / 8001/S-V	0	
		DOC. NO.	REV.	
		Page 23 of 31		

#### 40.0 TERMS OF PAYMENT

Payment shall be released after submitting valid Tax Invoice. GST no. of Contractor as well as Owner should be mentioned by the Contractor on Invoice.

Following terms of payment shall be applicable:

40.1 **Mobilization Advance:** Not Applicable

40.2 **Running on Account Payment**

Contractor shall raise the invoice for the 100% completed job against the RA bill and payment shall be release as per following manner:

**a) For Civil, Structural & Architectural works:**

95% against the value of actual work done shall be paid against running bills certified by OWNER/CONSULTANT after recovery of following payments:

- a) Value of chargeable materials issued by OWNER/CONSULTANT, if any
- b) Mobilization advances if any.
- c) Statutory deductions like income tax, etc. as applicable.
- d) Any other recovery if becomes due.
- e) Value of Chargeable Service provided by owner/Consultant, if any

Payment shall not be released against 1st R/A bill until submission of following documents by contractor to the indenting department.



1. Financial Guarantee for Performance
2. Labour License (as per statutory requirements)
3. EPF Code Registration number
4. Insurance Contractor All Risk (CAR) Policy
5. Workmen compensation policy

Balance 5% (Retention Money) shall be released along with final bill.

**b) ELECTRICAL / INSTRUMENTATION WORK**

**i. For Only Supply Items**

- 80% upon receipt of material at site and acceptance of equipment/materials
- 10% after completion of the erection
- 5 % after Inspection and Testing
- Balance 5% (Retention Money) shall be released along with final bill

	<b>ELECTRICAL WORKS (SUPPLY &amp; ERECTION) FOR ALTERNATE POWER SUPPLY ARRANGEMENT OF VIKARMPUR GUEST HOUSE AT TALCHER FERTILIZERS LTD., ANGUL, ODISHA SPECIAL CONDITIONS OF CONTRACT</b>	PC-183 / E / 8001/S-V	0	
		DOC. NO.	REV.	
		Page 24 of 31		

**ii. For Only Erection Items**

- 80% on completion of erection / Installation
- 15% after inspection/testing
- Balance 5% (Retention Money) shall be released along with final bill

**iii. For Items involving both Supply & Erection**

- 65% on receipt and acceptance of material at site.
- 20% on completion of erection / Installation.
- 10% on Inspection & testing.
- Balance 5% (Retention Money) shall be released along with final bill

**C) For Lumpsum Item:**



- 60% shall be paid against the approval of drawings/documents in Code-1
- 35 % shall be paid after completion of civil works
- Balance 5% (Retention Money) shall be released along with final bill.

40.3 Payment shall be released for supply of materials (wherever applicable) on submission of the following documents:

1. Signed Invoice(s)
2. Delivery Challan
3. Manufacturer's certificate of inspection for shipment in one original and one photocopy / Manufacturer's test certificate (wherever applicable)
4. Third Party Inspection Release Note clearly indicating that material has been inspected and accepted as per QAP approved by OWNER, or waiver certificate issued by OWNER (wherever applicable).
5. Railway Receipt/LR (wherever applicable)
6. Insurance Certificate/Intimation
7. Guarantee/ Warranty certificate (wherever applicable)
8. Operation & Maintenance manual (wherever applicable)

**Note :**

The amount of CGST & SGST or IGST and GST cess, if any will be released when the same will appear in the GSTR-2A of OWNER, in the common portal of GST and supplier has filed the valid return in accordance with the provisions of the GST Act and the rules made there under. If, input tax credit is not available to OWNER for any reason attributable to the bidder, then OWNER shall not be obligatory or liable to pay or reimburse GST claimed in invoice and shall be entitled to deduct /setoff/ recover such GST together with all

	<b>ELECTRICAL WORKS (SUPPLY &amp; ERECTION) FOR ALTERNATE POWER SUPPLY ARRANGEMENT OF VIKARMPUR GUEST HOUSE AT TALCHER FERTILIZERS LTD., ANGUL, ODISHA SPECIAL CONDITIONS OF CONTRACT</b>	PC-183 / E / 8001/S-V	0	
		DOC. NO.	REV.	
		Page 25 of 31		

the penalty and interest if any, against any paid or payable to bidder. Further in this case, OWNER reserves the right to upload the name of such defaulter on the Company website and may also consider for giving Holiday or debarred from participation in future tender.

#### 40.4 **PAYING AUTHORITY**

Director (Finance),  
Talcher Fertilizers Ltd.,  
C/o GAIL Training Institute, PARC Building,  
Plot No. 24, Sector – 16A, Film City, NOIDA (U. P.)

40.5 Payment in R.A. bills shall based on quantity of work executed at site (as per the item of work) & verified by Owner/ Consultant as per the Contract. Owner/ Consultant is authorized to allow part rate/ reduced rate for any item as mentioned in Contract. The engineer in charge shall specify the reason for the part rate payment in the R.A. bill. Payment has been made in R.A. bill for any item but later on, if some defect is noticed by the Owner/ Consultant, then Owner/ Consultant shall disallow the payment in successive R.A. bill till rectification of the work has been done.

#### 40.6 **RELEASE OF 1st R/A BILL**

Payment will be released against 1st R/A bill only on submission of following documents by contractor to the EIC/ OWNER:

- i. Contract Performance Security
- ii. Labour License (as per statutory requirements)
- iii. EPF Code Registration number with RPF/ARPF
- iv. Insurance Contractor All Risk (CAR) Policy
- v. Workmen compensation policy



40.7 Balance 5% (Retention Money) shall be released along with final bill subject to the following:

If the amount recoverable exceeds the amount payable in final bill, the balance amount shall be recovered by the Owner, from the retention money and or performance bank guarantee/any other moneys or bank guarantees available with the owner for any other job being done by the contractor. The contractor shall restore the performance guarantee to the requisite value to the extent of 3% of contract price in such case where recovery is required to be affected by the encashment of full amount or a part of the performance bank guarantee as soon as the contractor receives such intimation from the owner/ consultant.

40.8 The contractor shall raise invoices on fortnightly basis. Bidder shall enclose all documents as per check list issued by CONSULTANT/TFL. However, EIC may authorize payments for bills more frequently i.e. periodicity of less than fortnight, depending on site requirements.

After receipt of complete R.A. Bill as per terms and conditions of the contract and duly certified by Engineer-in-Charge (EIC), on-account payment equivalent to seventy percent (70%) of the net payable certified amount of the R.A. Bill will be released to the Contractor within a period of seven (07) working days from submission of certified bill by EIC to OWNER. The balance amount will be released within a period of 15 days from submission of certified bill by EIC to OWNER.

40.9 The final bill complete in all respect shall be submitted by the contractor within three (3) months of certified completion of work. The bill should be accompanied along with the following documents.

	<b>ELECTRICAL WORKS (SUPPLY &amp; ERECTION) FOR ALTERNATE POWER SUPPLY ARRANGEMENT OF VIKARMPUR GUEST HOUSE AT TALCHER FERTILIZERS LTD., ANGUL, ODISHA SPECIAL CONDITIONS OF CONTRACT</b>	PC-183 / E / 8001/S-V	0	
		DOC. NO.	REV.	
		Page 26 of 31		

1. Job completion certificate.
2. No claim certificate on Owner's prescribed proforma.
3. Site clearance certificate.
4. Contract Performance Security duly amended to cover Defect Liability Period.
5. Material reconciliation statement (statement of material issued by Owner or consultant to be got certified from stores dept.).
6. Indemnity certificate towards labour payment and all statutory payments.

No claim shall be entertained after receipt of final bill. Settlement of final bill shall be made subject to settlement of all disputes and furnishing of all required documents/clarifications and grant of extension of time, if any, by Owner's competent authority.

**In case any claim with regard to the wages of any labour employed by Contractor for the subject job is pending/ reported, TFL shall be fully entitled to withhold payment of final bill pending finalisation of such claims.**

#### **41.0 DISPATCH, TRANSPORTATION/SHIPPING**



CONTRACTOR shall be responsible for dispatch of EQUIPMENT by sea/ rail/ road/ air after proper packing and protection. The consignment shall be dispatched after inspection by Third Party Inspection Agency as specified in the Tender document, unless otherwise agreed to in writing however such inspection shall not constitute waiver of the CONTRACTOR's obligations, responsibilities for the EQUIPMENT including care, safety and preservation in any way and manner and the CONTRACTOR's responsibility and obligation in this behalf shall continue till ACCEPTANCE OF ENTIRE WORK .

**The Consignee for all bought-out material shall be CONTRACTOR.**



#### **42.0 WORK CONTRACT SERVICES**

- 42.1 The award of work shall be on 'Work Contract Service' basis. The contractor shall be responsible for payment of any tax levied on the transfer of property and goods involved with relevant GST act and rules made there under including amendments, if any. The contractor shall be liable to ensure to have registered with the respective tax authorities and to submit self-attested copy of such registration certificate(s) and any taxes/ duties/ levies being charged by the Contractor would be claimed by issuing proper tax invoice/ challan indicating details/ elements of all taxes charged and necessary requirements as prescribed under the respective tax laws and also to mention correct and valid registration number(s) on all tax invoices raised to TFL.





	<b>ELECTRICAL WORKS (SUPPLY &amp; ERECTION) FOR ALTERNATE POWER SUPPLY ARRANGEMENT OF VIKARMPUR GUEST HOUSE AT TALCHER FERTILIZERS LTD., ANGUL, ODISHA SPECIAL CONDITIONS OF CONTRACT</b>	PC-183 / E / 8001/S-V	0	
		DOC. NO.	REV.	
		Page 27 of 31		

- 42.2 Irrespective of single or separate insurances, the CONTRACTOR shall take the same in the joint name of OWNER and CONTRACTOR, with OWNER as Primary Beneficiary and CONTRACTOR as Joint Beneficiary, to cover all risk including marine cum erection insurance (MCE), workmen compensation / Employees State Insurance (ESI) under ESI Act 1948 for Contractor's personnel, fire risk policy etc. till handing over of PLANT to OWNER duly commissioned and tested. However, for CONTRACTOR's EQUIPMENT, CONTRACTOR can be the sole beneficiary. Further, OWNER shall have the first right over the claim amount for all insurance claims, where owner has made part or full payment to the contractor.
- 42.3 CONTRACTOR shall be fully responsible for pursuing and settling all claims under the underwriters. In the event of accident, injury, damage or loss likely to form a claim under the above insurance policies, CONTRACTOR shall, as quickly as possible submit the insurance claims by underwriters under intimation to OWNER. CONTRACTOR shall also keep OWNER fully informed about progress of each such case. CONTRACTOR shall undertake immediate repair and replacement of the equipment lost in transit, storage, assembly, erection and COMMISSIONING of PLANT pending settlement of claim thereafter by the underwriters.
- 42.4 The CONTRACTOR at his cost shall arrange, secure and maintain all insurance as may be pertinent to the works and obligatory in terms of law to protect his interest and interest of OWNER in the project, against all perils detailed herein. The Form and the limit of such insurance as defined herein together with the under-writer in each case shall be acceptable to the OWNER and OWNER's acceptance shall not be unreasonably withheld. However, irrespective of such acceptance, the responsibility to maintain adequate insurance coverage at all times including third party liability during the period of contract shall be as of CONTRACTOR alone. The contractor's failure in this regard shall not relieve him of any of his contractual responsibilities and obligations. The insurance covers to be taken by the CONTRACTOR shall be in the joint names of OWNER and the CONTRACTOR. The CONTRACTOR shall, however, be authorized to deal directly with insurance company or companies and shall be responsible in regard to maintenance of all insurance covers.
- 42.5 Any loss or damage to the equipment during handling, transportation, storage, erection, putting the equipment into satisfactory operation and all activities to be performed till the successful completion of trial operation of the plant shall be to the account of the CONTRACTOR. The CONTRACTOR shall be responsible for reference of all claims and make good the damages or loss by way of repairs and/or replacement of the equipment, damaged or lost. The transfer of title shall not in any way relieve the CONTRACTOR of the above responsibility during the period of CONTRACT. The CONTRACTOR shall provide the OWNER with copies of all insurance policies and documents taken out by him in pursuance of the CONTRACT. Such copies of documents shall be submitted to the OWNER immediately after such insurance coverage. However, if Marine cargo insurance or Third party liability Insurance is a part of their global policies; insurer certificate (including the main terms of policy) shall be submitted by CONTRACTOR. The CONTRACTOR shall also inform the OWNER in the writing at least thirty (30) days in advance regarding the expiry/ cancellation and/or change in any of such documents and ensure revalidation, renewal etc. as may be necessary well in time. However adequacy, credibility and maintenance of Insurance policies is the sole responsibility of CONTRACTOR and CONTRACTOR shall keep the OWNER indemnified against any such failure.

	<b>ELECTRICAL WORKS (SUPPLY &amp; ERECTION) FOR ALTERNATE POWER SUPPLY ARRANGEMENT OF VIKARMPUR GUEST HOUSE AT TALCHER FERTILIZERS LTD., ANGUL, ODISHA SPECIAL CONDITIONS OF CONTRACT</b>	PC-183 / E / 8001/S-V	0	
		DOC. NO.	REV.	
		Page 28 of 31		

- 42.6 If the material/ equipment or any portion thereof is damaged or lost during transit and handling, storage, erection, commissioning at site, the replacements of such material / equipment shall be effected by the CONTRACTOR within a reasonable time to avoid unnecessary delay in the COMMISSIONING of the EQUIPMENT and without waiting for realization of cost of damages from the insurance company, appointed by him for this purpose. This will not alter the schedule of commissioning & guarantee tests in any way.
- 42.7 All works and operations necessary to lift and to remove the material from port, warehouse, railway or other siding, factory or other places of delivery, loading, handling, transporting and unloading and safely stacking, placing or storing the same at approved godowns, yards or other place(s) of storage including lashing or other-wise securing or protecting the same in transit and during and in storage.
- 42.8 The CONTRACTOR shall maintain a day-to-day account of all materials indicating the daily receipt(s), consumption(s) and balance of each material and category thereof. Such account shall be in the format, if any, prescribed by the Engineer-in-Charge and shall be supported by all documents necessary to verify the correctness of the entries in the account. Such account shall be maintained at the CONTRACTOR MANAGER"s office and site(s) and shall be open for inspection and verification (by verification of documents in support of the entry as also by feasible verification of the stock) at all times by the Engineer-in-Charge with authority at all times without obstruction to enter into or upon any godown or other place(s) or premise(s) where the materials or any part of them are lying or stored and to inspect the same himself and or through his representative(s).
- 42.9 The CONTRACTOR shall at all times be exclusively responsible for any and all losses, damages, deterioration, misuse, wastage, theft, or other application or misapplication or disposal of the materials or any of them contrary to the provisions hereof and shall keep the OWNER indemnified from and against the same and shall forthwith at its own cost and expenses replace any such material, lost, damaged, deteriorated, misused, wasted, stolen, applied, mis-applied and/or disposed as aforesaid with other material of equivalent quality and quantity delivered to site at the CONTRACTOR"s risks and costs in all respects.
- 42.10 Notwithstanding anything herein provided, the CONTRACTOR shall be and remain solely and exclusively liable to repair, restore or replace, as the case may be, the materials damaged or destroyed as a result of any act or omission, notwithstanding the existence or otherwise of any policy(ies) of insurance aforesaid, with the intent that any policy(ies) of insurance aforesaid taken out by the CONTRACTOR or by the OWNER, on default by the CONTRACTOR, shall not anyway absolve the CONTRACTOR from his full liability up to and until issue of the Completion Certificate as provided for herein in respect of the works, the work(s) and all materials incorporated therein shall be and remain at the risks of the CONTRACTOR in all respects, including (but not limited to) accident, lightning, earth-quake, fire, storm, flood, tempest, riot, civil commotion and/or war or otherwise with respect to the materials, but shall constitute merely an additional security and not a substitution of liability.

	<b>ELECTRICAL WORKS (SUPPLY &amp; ERECTION) FOR ALTERNATE POWER SUPPLY ARRANGEMENT OF VIKARMPUR GUEST HOUSE AT TALCHER FERTILIZERS LTD., ANGUL, ODISHA SPECIAL CONDITIONS OF CONTRACT</b>	PC-183 / E / 8001/S-V	0	
		DOC. NO.	REV.	
		Page 29 of 31		

42.11 If the CONTRACTOR shall default in replacing at the job site, free of any cost to the OWNER, any material lost, damaged, deteriorated, misused, wasted, short, stolen, misapplied or disposed of within the provisions hereof above, or shall fail to return to the OWNER any surplus material or empties within the provision hereof above, the CONTRACTOR shall be liable to pay to the OWNER the cost of such materials or empties delivered at OWNER"s stockpile/ godown.

#### **43.0 CONSTRUCTION EQUIPMENT, TOOLS AND TACKLES DEPLOYMENT**

i. ~~The details of key construction equipment in good condition, required to be mobilized by the contractor, to complete the work within the schedule is listed below (not limited to only the following) :-~~

Sl. No.	Equipment Description
1	Hydraulic Telescopic Boom Pick & Carry Crane of suitable capacity
2	Hydraulic Excavator
3	Dumper
4	Tractor Trailer
5	Water Tanker
6	Total Station
7	Dumpy level
8	Welding Machine
9	Dewatering Pump
10	Concrete Mixer
11	Electrical tool Kit
12	Breaker
13	Manual/ Electrical Lifting Equipment/ Hoists/ Pullers of suitable capacity
14	Any, other equipments to complete the job

ii. ~~Contractor to confirm that the above equipments are available with him in good working condition and shall be timely mobilized on this project site. Contractor has the option to hire some these equipment from equipment hiring agencies also, however contractor shall be responsible for all the machinery deployed at site.~~

iii. ~~In addition to above, Contractor shall be required to deploy all the machinery/ tools & tackles at site as required for the successful completion of the job/ as directed by the Engineer in-charge.~~



iv. ~~Owner/ consultant reserve the right to physically check & verify the availability of these equipments prior to award of work~~

v. ~~Contractor shall replace any defective/ damaged equipment promptly to complete the work without any time & cost implication to the owner/ consultant~~

vi. ~~The actual deployment of equipments shall be finalized or approved by Engineer in-charge.~~

#### **44.0 BOCW (BUILDING AND OTHER CONSTRUCTION WORKS)**

Applicable BOCW shall be included in the quoted TOTAL CONTRACT PRICE. The contractor shall pay the cess under BOCW Act for subject works and submit proof of submission of cess to owner before submitting the next R.A. bill. In case, contractor does not

	<b>ELECTRICAL WORKS (SUPPLY &amp; ERECTION) FOR ALTERNATE POWER SUPPLY ARRANGEMENT OF VIKARPUR GUEST HOUSE AT TALCHER FERTILIZERS LTD., ANGUL, ODISHA SPECIAL CONDITIONS OF CONTRACT</b>	PC-183 / E / 8001/S-V	0	
		DOC. NO.	REV.	
		Page 30 of 31		

submit the said proof, applicable BOCW shall be deducted at source by the OWNER from the contractor's invoice and deposit the deducted amount to the concerned authority. OWNER does not undertake any further responsibility in this regard.

#### **45.0 COMPLIANCE TO DMI & SP (DOMESTICALLY MANUFACTURED IRON & STEEL PRODUCTS) POLICY**



##### **(THIS POLICY IS NOT APPLICABLE FOR THIS TENDER)**

~~Contractor shall ensure compliance to the DMI&SP policy as per updated policy issued by the Government of India from time to time. The Policy is attached as **Annexure II** for reference (**Annexure to Special Conditions of Contract**).~~

~~Format for Affidavit & Undertaking with respect to Policy for providing preference to domestically manufactured Iron & Steel products is attached as Form **F-18** in the ITB.~~

#### **46.0 SUB-CONTRACTOR/VENDOR AND MANUFACTURER WARRANTIES**

- (a) CONTRACTOR shall ensure that all equipment and other items used in connection with the performance of the WORK or incorporated in the PLANT (other than minor items) will be purchased in compliance with CONTRACT Technical Specifications and requirements in order to allow the PLANT to achieve the Guarantee and Warrantee as provided for in the CONTRACT, unless otherwise agreed with OWNER. Any residual warranty from sub-contractor/vendor shall be passed to the OWNER after expiry of DEFECT LIABILITY PERIOD.
- (b) Neither CONTRACTOR nor its SUB-CONTRACTORS/SUB-VENDORS nor any person under the control of either thereof, shall take any action which could release, void, impair or waive any Guarantee or Warranty on EQUIPMENT or services relating to the PROJECT or the WORK. Any residual warranty from sub-contractor/sub-vendor shall be passed to the OWNER after expiry of DEFECT LIABILITY PERIOD.
- (c) Nothing in this clause shall derogate from the obligations of CONTRACTOR to provide the Guarantees and Warranties described in and to comply with the provisions hereinabove.
- (d) CONTRACTOR shall, based on its past professional judgement, enforce all guarantees and warranties provided hereunder to the fullest extent thereof till such time they are transferred to the OWNER pursuant to sub-clause (g) below.
- (e) Upon the expiration or termination of any of the guarantees or warranties provided by CONTRACTOR pursuant to the CONTRACT, the CONTRACTOR shall assign, and hereby assigns, effective as of such date, or otherwise make available, to OWNER all of CONTRACTOR's rights under all such SUBCONTRACTOR's residual Guarantees and warrantee as per 45.0 (a) & (b) (except to the extent CONTRACTOR has thereof provided warranty services to OWNER and is enforcing CONTRACTOR's rights with respect to such services under the applicable guarantee or warranty) and shall deliver to OWNER copies of all contracts providing for such guarantees and warranties.
- (f) CONTRACTOR, in accordance with the CONTRACT, shall require all SUB-CONTRACTORS/ SUB-VENDORS to be covered by the insurance covers specified in the CONTRACT, during the time in which they are engaged in performing WORK.
- (g) CONTRACTOR shall require all SUB-CONTRACTORS/ SUB-VENDORS to release and waive any and all rights of recovery against OWNER including its

	<b>ELECTRICAL WORKS (SUPPLY &amp; ERECTION) FOR ALTERNATE POWER SUPPLY ARRANGEMENT OF VIKARMPUR GUEST HOUSE AT TALCHER FERTILIZERS LTD., ANGUL, ODISHA SPECIAL CONDITIONS OF CONTRACT</b>	PC-183 / E / 8001/S-V	0	
		DOC. NO.	REV.	
		Page 31 of 31		

affiliates, subsidiaries, employees, successors, permitted assigns, insurers and underwriters) and against CONTRACTOR and all other SUB-CONTRACTORS/ VENDORS which the releasing SUB-CONTRACTOR/ VENDOR may otherwise have or acquire, in or from or in any way connected with any loss covered by policies of insurance maintained or required to be maintained pursuant to this the CONTRACT (other than third party liability insurance policies) or because of deductible clauses in or inadequacy of limits of any such policies of insurance. CONTRACTOR shall further require all SUB-CONTRACTORS/VENDORS to include in all policies of insurance maintained by the SUB-CONTRACTORS/ VENDORS clauses providing that each underwriter shall release and waive all of its rights of recovery, under subrogation or otherwise, against OWNER, its promoters, affiliates, subsidiaries, employees, successors, permitted assigns, insurers and underwriters, and against CONTRACTOR and all other SUB-CONTRACTORS/VENDORS.



- (h) OWNER shall not be deemed by virtue of the CONTRACT to have any contractual obligation to or relationship with any SUB-CONTRACTOR/ VENDOR.

#### **47.0 CONTRACTOR's LIABILITY FOR APPROVED SUB CONTRACTOR :**

The review by and approval and consent of OWNER as to the approved SUB-CONTRACTORS list or as to CONTRACTOR entering into any SUB-CONTRACT with any approved SUB-CONTRACTOR or as to any WORK done or supply made or services provided by any such approved SUB-CONTRACTOR/ SUB-VENDOR shall not relieve CONTRACTOR of any of his duties, liabilities or obligations under this CONTRACT, and CONTRACTOR shall be liable hereunder to the same extent as if any such SUB-CONTRACT had not been entered into. Any inspection review or approval by OWNER permitted under this CONTRACT of any portion of the work or of any work in progress by CONTRACTOR or SUB-CONTRACTORS/ SUB-VENDORS shall not relieve CONTRACTOR of any duties, liabilities or obligations under this CONTRACT.

 <b>पी डी आई एल PDIL</b>	<b>PROJECTS &amp; DEVELOPMENT INDIA LIMITED</b>	PC-183 / E / 8001 /S-V	0	 <b>Talcher Fertilizers</b>
		DOC. NO.	REV.	
		Page 1 of 18		

**ANNEXURE - I**  
**TO**  
**SPECIAL CONDITIONS OF CONTRACT**  
  
**SPECIFICATION**  
**FOR**  
**HEALTH, SAFETY AND**  
**ENVIRONMENT (HSE) MANAGEMENT**

	<b>ELECTRICAL WORKS (SUPPLY &amp; ERECTION) FOR ALTERNATE POWER SUPPLY ARRANGEMENT OF VIKARMPUR GUEST HOUSE AT TALCHER FERTILIZERS LTD., ANGUL, ODISHA</b>	PC-183 / E / 8001 /S-V	0	
		DOC. NO.	REV.	
		Page 2 of 18		
<b>HEALTH, SAFETY AND ENVIRONMENT (HSE) MANAGEMENT</b>				



## TABLE OF CONTENTS

1.0	SCOPE.....	3
2.0	REFERENCES.....	3
3.0	REQUIREMENTS OF HEALTH, SAFETY & ENVIRONMENT (HSE) MANAGEMENT SYSTEM TO BE COMPILED BY BIDDERS .....	3
4.0	DETAILS OF HSE MANAGEMENT SYSTEM BY CONTRACTOR.....	7

### ANNEXURES: -

1. ANNEXURE-1 A : RELEVANT I.S. CODES
2. ANNEXURE-1 B : REPORTING FORMATS



	<b>ELECTRICAL WORKS (SUPPLY &amp; ERECTION) FOR ALTERNATE POWER SUPPLY ARRANGEMENT OF VIKARMPUR GUEST HOUSE AT TALCHER FERTILIZERS LTD., ANGUL, ODISHA</b>	PC-183 / E / 8001 /S-V	0	
		DOC. NO.	REV.	
		Page 3 of 18		
<b>HEALTH, SAFETY AND ENVIRONMENT (HSE) MANAGEMENT</b>				

## 1.0 SCOPE

This Specification establishes the Health, Safety and Environment (HSE) management requirement to be complied with by the Contractors during construction. Requirements stipulated in this specification shall supplement the requirements of HSE Management given in relevant Act (s)/ legislations. General Conditions of Contract (GCC), Special Conditions of Contract (SCC), and Job Specifications. Where different documents stipulate for different requirements, the most stringent shall be adopted.

## 2.0 REFERENCES

This document should be read in conjunction with following:

- General Conditions of Contract (GCC)
- Special Condition of Contract (SCC)
- Job Specifications
- Relevant IS Codes (Refer Annexure-IA)
- Reporting Formats (Refer Annexure-IB)

## 3.0 REQUIREMENTS OF HEALTH, SAFETY & ENVIRONMENT (HSE) MANAGEMENT SYSTEM TO BE COMPILED BY BIDDERS

### 3.1 MANAGEMENT RESPONSIBILITY

The contractor should have a documented HSE policy to cover commitment of their organization to ensure health, safety and environment aspects in their line of operation.

3.1.2 The HSE management system of the Contractor shall cover the HSE requirements including but not limited to what is specified under Para 1.0 and Para 2.0 above.



3.1.3 Contractor shall be fully responsible for planning and implementing HSE requirements. Contractor as a minimum requirement shall designate/deploy the following to coordinate the above.

No. of workers deployed  
Upto 250

- Deploy one qualified and experienced  
safety Engineer/Officer

Above 250 & Upto 500

- One additional safety engineer/officer,  
as above



	<b>ELECTRICAL WORKS (SUPPLY &amp; ERECTION) FOR ALTERNATE POWER SUPPLY ARRANGEMENT OF VIKARMPUR GUEST HOUSE AT TALCHER FERTILIZERS LTD., ANGUL, ODISHA</b>	PC-183 / E / 8001 /S-V	0	
		DOC. NO.	REV.	
		Page 4 of 18		
<b>HEALTH, SAFETY AND ENVIRONMENT (HSE) MANAGEMENT</b>				

Above 500  
(For every 500 or less)

- One additional safety engineer/officer,  
for each 200 workers.

Contractor shall indemnify & hold harmless Owner/Consultant & their representatives free from any and all liabilities arising out of non-fulfillment of HSE requirements.

- 3.1.4 The Contractor shall ensure that the Health, Safety and Environment (HSE) requirements are clearly understood & faithfully implemented at all levels at site.
- 3.1.5 The Contractor shall promote and develop consciousness for Health Safety and Environment among all personnel working for the Contractor. Regular awareness programs and fabrication shop/work site meetings shall be arranged on HSE activities to cover hazards involved in various operations during construction.
- 3.1.6 Arrange suitable First-Aid measures such as First Aid Box, trained personnel to First Aid, Standby Ambulance or Vehicle and install fire protection measures such as adequate number of steel buckets with sand and water and adequate extinguishers to the satisfaction of Consultant/Owner.
- 3.1.7 The Contractor shall evolve a comprehensive planned and documented system for implementation and monitoring of the HSE requirements. This shall be submitted to Consultant/Owner for approval. The monitoring for implementation shall be done by regular inspections and compliance to the observations thereof. The Contractor shall get similar HSE requirements implemented at his sub-contractor(s) work site/office. However, compliance of HSE requirements shall be the sole responsibility of Contractor. Any review/approval by Consultant/Owner shall not absolve contractor of his responsibility / liability in relation to all HSE requirements.
- 3.1.8 Non-Conformance on HSE by Contractor (including his Sub-contractors) as brought out during review/audit by Consultant/Owner representative shall be resolved forthwith by Contractor. Compliance report shall be provided to Consultant/Owner.
- 3.1.9 The Contractor shall ensure participation of his Resident Engineer/ Site-in-Charge in the Safety Committee / HSE Committees. Meetings arranged by Consultant/Owner. The compliance of any observations shall be arranged urgently. He shall assist Consultant/Owner to achieve the targets set by them on HSE during the project implementation.
- 3.1.10 The Contractor shall adhere consistently to all provisions of HSE requirements. In case of non-compliance or continuous failure in implementation of any of HSE provisions; Consultant/Owner may impose stoppage of work without any Cost & time implication to Owner and/or impose a suitable penalty for noncompliance with a notice of suitable period upto a cumulative limit of 1.0% (one percent) of Contract Value with a ceiling of Rs 10 lakhs. This penalty shall be in addition to all other penalties specified else where in the contract. The decision of imposing stoppage

	<b>ELECTRICAL WORKS (SUPPLY &amp; ERECTION) FOR ALTERNATE POWER SUPPLY ARRANGEMENT OF VIKARMPUR GUEST HOUSE AT TALCHER FERTILIZERS LTD., ANGUL, ODISHA</b>	PC-183 / E / 8001 /S-V	0	
		DOC. NO.	REV.	
		Page 5 of 18		
<b>HEALTH, SAFETY AND ENVIRONMENT (HSE) MANAGEMENT</b>				

work, its extent & monetary penalty shall rest with Consultant/Owner & binding on the Contractor.

3.1.11 However **fatal accident** may lead to termination of the Contract. The personnel accidents shall be investigated by a team of Contractor's senior personnel for root cause & recommend corrective and preventive actions. Findings shall be documented and suitable actions taken to avoid recurrences shall be communicated to Consultant/Owner. Owner/Consultant shall have the liberty to independently investigate such occurrences and Contractor shall extend all necessary help and co-operation in this regard.



### 3.2.0 HOUSE KEEPING

3.2.1 Contractor shall ensure that a high degree of house keeping is maintained and shall ensure inter-racial the followings:

- a. All surplus earth and debris are removed/disposed off from the working areas to identified location(s).
- b. Unused / Surplus Cables different places within location(s). Steel items and steel scrap lying scattered at the working areas are removed to identified
- c. All wooden scrap, empty wooden cable drums and other combustible packing materials, shall be removed from work place to indemnified location(s).
- d. Roads shall be kept clear and materials like pipes steel sand, boulders concrete, chips and bricks etc shall not be allowed on the roads to obstruct free movement of men & machineries.
- e. Fabricated steel structural, pipes & piping materials shall be stacked properly for erection.
- f. Water logging on roads shall not be allowed.
- g. No parking of trucks/trolleys, cranes and trailers etc shall be allowed on roads which may obstruct the traffic movement.
- h. Utmost care shall be taken to ensure over all cleanliness and proper upkeep of the working areas.
- i. Trucks carrying sand, earth and pulverized materials etc shall be covered while moving within the plant area.



### 3.3.0 HEALTH, SAFETY AND ENVIRONMENT

3.3.1 The Contractor shall provide safe means of access to any working place including provisions of suitable and sufficient scaffolding at various stages during all operations

	<b>ELECTRICAL WORKS (SUPPLY &amp; ERECTION) FOR ALTERNATE POWER SUPPLY ARRANGEMENT OF VIKARMPUR GUEST HOUSE AT TALCHER FERTILIZERS LTD., ANGUL, ODISHA</b>	PC-183 / E / 8001 /S-V	0	
		DOC. NO.	REV.	
		Page 6 of 18		
<b>HEALTH, SAFETY AND ENVIRONMENT (HSE) MANAGEMENT</b>				

of the work for the safety of his workmen, and, Consultant/Owner. Contractor shall ensure deployment of appropriate equipment and appliances for adequate safety and health of the workmen and protection of surrounding areas.

- 3.3.2 The Contractor shall ensure that all their staff and workers including their subcontractor(s) shall wear Safety Helmet and Safety shoes. Contractor shall also ensure, use of safety belt protective goggles, gloves etc. by the personnel as per job requirements. All these gadgets shall conform to relevant IS specifications or equivalent.
- 3.3.3 Contractor shall ensure that a proper Safety Net System shall be used at appropriate locations. The safety net shall be located not more than 30 feet (9.0 meters) below the working surface at site to arrest or to reduce the consequences of a possible fall of persons working at different heights.
- 3.3.4 Contractor shall ensure that flash back arrester shall be used while using Gas Cylinders at site. Cylinders shall be mounted on trolleys.
- 3.3.5 The Contractor shall assign to his workmen tasks commensurate with their qualification experience and state of health for driving of vehicles, handling and erection of materials and equipments. All lifting equipments shall test certified for its capacity before use. Adequate and suitable lighting at every work place and approach there to, shall be provided by the contractor before starting the actual operations at night.
- 3.3.6 Hazardous and/or toxic materials such as solvent coating or thinners shall be stored in appropriate containers.
- 3.3.7 All hazardous materials shall be labeled with the name of materials the hazards associated with its use and necessary precautions to be taken.
- 3.3.8 Contractor shall ensure that during performance of the work, all hazards to the health of personnel have been indemnified, assessed and eliminated.
- 3.3.9 Chemical spills shall be contained & cleaned up immediately to prevent further, contamination.
- 3.3.10 All personnel exposed to physical agents such as ionizing or non-ionizing radiations ultraviolet rays or similar other physical agents shall be provided with adequate shielding or protection commensurate with the type of exposure involved.
- 3.3.11 Where contact or exposure of hazardous materials could exceed limits or could otherwise have harmful affects, appropriate personal protective equipments such as gloves, goggles, aprons chemical resistant clothing and respirator shall be used.
- 3.3.12 Suitable facilities for toilet, drinking water, proper lighting shall be provided at site and labor camps, commensurate with applicable Laws/Legislation.

	<b>ELECTRICAL WORKS (SUPPLY &amp; ERECTION) FOR ALTERNATE POWER SUPPLY ARRANGEMENT OF VIKARMPUR GUEST HOUSE AT TALCHER FERTILIZERS LTD., ANGUL, ODISHA</b>	PC-183 / E / 8001 /S-V	0	
		DOC. NO.	REV.	
		Page 7 of 18		
<b>HEALTH, SAFETY AND ENVIRONMENT (HSE) MANAGEMENT</b>				

3.3.13 Contractor shall ensure storage and utilization methodology of materials that are not detrimental to environment. Where required, Contractor shall ensure that only the environment friendly materials are selected.

3.3.15 All persons deployed at site shall be knowledgeable of and comply with the environment laws, rules & regulations relating to the hazardous materials substances and wastes. Contractor shall not dump release or otherwise discharge or dispose off any such materials without the express authorization of Consultant / Owner.

#### 4.0 DETAILS OF HSE MANAGEMENT SYSTEM BY CONTRACTOR

##### 4.1 On Award of Contract



The Contractor shall prior to start of work submit his Health, Safety and Environment Manual or procedure and HSE Plans for approval by Consultant/Owner. The contractor shall participate in the pre-start meeting with Consultant/Owner to finalize HSE Plans including the following.

- Job procedure to be followed by Contractor for activities covering handling of equipments, Scaffolding, Electric Installation, describing the risks involved, actions to be taken and methodology for monitoring each activity.
- Consultant/Owner review /audit requirements.
- Organization structure along with responsibility and authority records/ reports etc on HSE activities.

##### 4.2 During job execution

4.2.1 Implement approved Health, Safety and Environment management procedure including but not limited to as brought out under Para 3.0. Contractor shall also ensure to:



- Arrange workmen compensation insurance registration under ESI Act third party liability insurance etc, as applicable:
- Arrange all HSE permits before start of activities (as applicable) like hot work, confined space, work at heights, storage of chemicals/explosive materials and its use and implement all precautions mentioned their in.
- Submit timely the completed checklist on HSE activities, Monthly HSE reports, accident reports, and investigation reports etc as per Consultant/Owner requirements. Compliance of instructions on HSE shall be done by contractor and informed urgently to Consultant /Owner.
- Ensure that resident Engineer/Site-In-Charge of the Contractor shall attend all the Safety Committee/HSE meetings arranged by Consultant/Owner. Only in

	<b>ELECTRICAL WORKS (SUPPLY &amp; ERECTION) FOR ALTERNATE POWER SUPPLY ARRANGEMENT OF VIKARMPUR GUEST HOUSE AT TALCHER FERTILIZERS LTD., ANGUL, ODISHA</b>	PC-183 / E / 8001 /S-V	0	
		DOC. NO.	REV.	
		Page 8 of 18		
<b>HEALTH, SAFETY AND ENVIRONMENT (HSE) MANAGEMENT</b>				

case of his absence from site that a second senior most person shall be nominated by him in advance and communicated to Consultant/Owner.

- Display at site office and work locations caution boards list of hospitals emergency services available.
- Provide posters, banners for safe working to promote safety consciousness.
- Carry out audits/inspection at sub-contractor works as per approved HSE document & submit the reports for Consultant/Owner review.
- Assist in HSE audits by Consultant /Owner and submit compliance reports
- Generate & submit HSE records/report as per HSE Plan.
- Appraise Consultant /Owner on HSE activities at site.

## ANNEXURE -1A

	<b>ELECTRICAL WORKS (SUPPLY &amp; ERECTION) FOR ALTERNATE POWER SUPPLY ARRANGEMENT OF VIKARMPUR GUEST HOUSE AT TALCHER FERTILIZERS LTD., ANGUL, ODISHA</b>	PC-183 / E / 8001 /S-V	0	
		DOC. NO.	REV.	
		Page 9 of 18		
<b>HEALTH, SAFETY AND ENVIRONMENT (HSE) MANAGEMENT</b>				

### RELEVANT IS - CODES FOR PERSONAL PROTECTION



IS: 2925 - 1984	Industrial Safety Helmets
IS: 4770 - 1968	Rubber gloves for electrical purposes
IS: 6994 - 1973 (Part-I)	Industrial Safety Gloves (Leather & Conon Gloves)
IS: 1989 - 1986 (Part -I & III)	Leather safety boots and shoes
IS: 3738 - 1975	Rubber knee boots
IS: 5557 - 1969	Industrial and Safety rubber knee boots
IS: 6519 - 1971	Code of practice for selections, care and repair of Safety footwear
IS: 11226 - 1985	Leather Safety footwear having direct moulding sole
IS: 5983 - 1978	Eye protectors
IS: 9167 -1979	Ear protectors
IS: 3521 -1983	Industrial Safety belts and harness

#### NOTE:

For necessary Codes for safety/Environmental requirement, concerned statutory authorities may be consulted.





	<b>ELECTRICAL WORKS (SUPPLY &amp; ERECTION) FOR ALTERNATE POWER SUPPLY ARRANGEMENT OF VIKARMPUR GUEST HOUSE AT TALCHER FERTILIZERS LTD., ANGUL, ODISHA</b>  <b>HEALTH, SAFETY AND ENVIRONMENT (HSE) MANAGEMENT</b>	PC-183 / E / 8001 /S-V	0	
		DOC. NO.	REV.	
		Page 11 of 18		

**PROJECT:**

**CONTRACTOR:**

**DATE:**



**OWNER:**

**INSPECTION BY:**

**NOTE:** Write N.A. where the item is not applicable.



ITEM	Yes	No	Remarks	Action
<b>HOUSEKEEPING</b>				
Waste containers provided and used				
Sanitary facilities adequate and clean				
Passageways and walkways clear				
General neatness of working areas				
Other				
<b>PERSONAL PROTECTIVE EQUIPMENTS</b>				
Goggles, Shields				
Face protection				
Hearing protection				
Safety shoes provided				
Hand protection				
Respiratory mask etc.				
Safety belts				
Other				
<b>EXCAVATION / OPENINGS</b>				
Opening properly covered or barricaded				
Excavation shored				
Excavation barricaded				
Overnight lightening provided				
Other				

**MONTHLY HSE CHECKLIST CUM COMPLIANCE REPORT (2/6)**



	<b>ELECTRICAL WORKS (SUPPLY &amp; ERECTION) FOR ALTERNATE POWER SUPPLY ARRANGEMENT OF VIKARMPUR GUEST HOUSE AT TALCHER FERTILIZERS LTD., ANGUL, ODISHA</b>	PC-183 / E / 8001 /S-V	0	
		DOC. NO.	REV.	
		Page 12 of 18		
<b>HEALTH, SAFETY AND ENVIRONMENT (HSE) MANAGEMENT</b>				

ITEM	Yes	No	Remarks	Action
<b>WELDING ,CUTTING</b>				
Gas cylinders chained upright				
Cables and hoses not obstructing				
Screens or shields used				
Flammable materials protected				
Fire extinguisher (s) accessible				
other				
<b>SCAFFOLDING</b>				
Fully decked platforms				
Guard and intermediate rails in place				
Toe boards in place				
Adequate shoring				
Adequate access				
Other				
<b>LADDERS</b>				
Extension side rails 1 m above				
Top of landing				
Properly secured				
Angle $\pm 70^\circ$ from horizontal				
Other				

**MONTHLY HSE CHECKLIST CUM COMPLIANCE REPORT (Contd. 3/6)**

	<b>ELECTRICAL WORKS (SUPPLY &amp; ERECTION) FOR ALTERNATE POWER SUPPLY ARRANGEMENT OF VIKARMPUR GUEST HOUSE AT TALCHER FERTILIZERS LTD., ANGUL, ODISHA</b>	PC-183 / E / 8001 /S-V	0	
		DOC. NO.	REV.	
		Page 13 of 18		
<b>HEALTH, SAFETY AND ENVIRONMENT (HSE) MANAGEMENT</b>				



ITEM	Yes	No	Remarks	Action
<b>HOISTS, CRANES AND DERRICKS</b>				
Condition of cables and sheaves OK				
Condition of slings, chains hooks and eyes O.K.				
Inspection and maintenance logs maintained				
Outriggers used				
Sign/I barricades provided				
signals observed and understood				
Qualified operators				
Other				
<b>MACHINERY, TOOLS AND EQUIPMENT</b>				
Proper instruction				
Safety devices				
Proper cords				
Inspection and maintenance				
Other				
<b>VEHICLE AND TRAFFIC</b>				
Rules and regulations observed				
Inspection and maintenance				
Licensed drivers				
Others				

	<b>ELECTRICAL WORKS (SUPPLY &amp; ERECTION) FOR ALTERNATE POWER SUPPLY ARRANGEMENT OF VIKARMPUR GUEST HOUSE AT TALCHER FERTILIZERS LTD., ANGUL, ODISHA</b>  <b>HEALTH, SAFETY AND ENVIRONMENT (HSE) MANAGEMENT</b>	PC-183 / E / 8001 /S-V	0	
		DOC. NO.	REV.	
		Page 14 of 18		

### MONTHLY HSE CHECKLIST CUM COMPLIANCE REPORT (Contd. 4/6)



ITEM	Yes	No	Remarks	Action
<b>TEMPORARY FACILITIES</b>				
Emergency instructions posted				
Fire extinguisher provided				
Fire-aid equipment available				
Secured against storm damage				
General neatness				
In accordance with electrical requirements				
Other				
<b>FIRE PREVENTION</b>				
Personnel instructed				
Fire extinguishers checked				
No smoking in prohibited areas.				
Hydrants Clear				
Other				
<b>ELECTRICAL</b>				
Proper wiring				
ELCB's provided				
Ground fault circuit interrupters				
Protection against damage				
Prevention of tripping hazards				
Other				

### MONTHLY HSE CHECKLIST CUM COMPLIANCE REPORT (Contd. 5/6)

	<b>ELECTRICAL WORKS (SUPPLY &amp; ERECTION) FOR ALTERNATE POWER SUPPLY ARRANGEMENT OF VIKARMPUR GUEST HOUSE AT TALCHER FERTILIZERS LTD., ANGUL, ODISHA</b>	PC-183 / E / 8001 /S-V	0	
		DOC. NO.	REV.	
		Page 15 of 18		
<b>HEALTH, SAFETY AND ENVIRONMENT (HSE) MANAGEMENT</b>				

ITEM	Yes	No	Remarks	Action
<b>HANDLING AND STORAGE OF MATERIALS</b>				
Properly Stored or stacked				
Passageways clear				
Other				
<b>FLAMMABLE GASES AND LIQUIDS</b>				
Container clearly identified				
Proper storage				
Fire extinguishers nearby				
Other				
<b>WORKING AT HEIGHT</b>				
Erection plan				
Safety nets				
Safety belts and lanyards: chute lines				
Other				
<b>ENVIRONMENT</b>				
Chemical and other Effluents properly disposed				
Cleaning liquid of pipes disposed off properly				
Sea water used for hydro-testing disposed off as per agreed procedure				
Lubricant waste/Engine oils properly disposed				
Waste from Canteen, offices, sanitation etc disposed properly				
Disposal of surplus earth stripping materials Oily rags and combustible materials done properly				
Green belt protection				

**MONTHLY HSE CHECK LIST CUM COMPLIANCE REPORT (Contd. 6/6)**



	<b>ELECTRICAL WORKS (SUPPLY &amp; ERECTION) FOR ALTERNATE POWER SUPPLY ARRANGEMENT OF VIKARMPUR GUEST HOUSE AT TALCHER FERTILIZERS LTD., ANGUL, ODISHA</b>  <b>HEALTH, SAFETY AND ENVIRONMENT (HSE) MANAGEMENT</b>	PC-183 / E / 8001 /S-V	0	
		DOC. NO.	REV.	
		Page 16 of 18		

ITEM	Yes	No	Remarks	Action
<b>HEALTH CHECKS</b>				
Hygienic conditions at labour camps O.K.				
Availability of first Aid facilities				
Proper sanitation at site ,office and labour camps				
Arrangement of medical facilities				
Measures for dealing with illness				
Availability of potable drinking water for working and staff				
Provision of crèches for children				

(Signature of Resident Engineer with Seal)

### 3.0 ACCIDENT CUM FIRE REPORT





	<b>ELECTRICAL WORKS (SUPPLY &amp; ERECTION) FOR ALTERNATE POWER SUPPLY ARRANGEMENT OF VIKARMPUR GUEST HOUSE AT TALCHER FERTILIZERS LTD., ANGUL, ODISHA</b>	PC-183 / E / 8001 /S-V	0	
		DOC. NO.	REV.	
		Page 17 of 18		
<b>HEALTH, SAFETY AND ENVIRONMENT (HSE) MANAGEMENT</b>				

STANDARD TFL FORMAT SHALL BE SUPPLIED AT SITE

4.0 **SUPPLEMENTRY ACCIDENT & INVESTIGATION REPORT**

STANDARD TFL FORMAT SHALL BE SUPPLIED AT SITE

**5.0 MONTHLY HEALTH, SAFETY & ENVIRONMENT (HSE) REPORT**  
(To be submitted by each Contractor)

	<b>ELECTRICAL WORKS (SUPPLY &amp; ERECTION) FOR ALTERNATE POWER SUPPLY ARRANGEMENT OF VIKARMPUR GUEST HOUSE AT TALCHER FERTILIZERS LTD., ANGUL, ODISHA</b>  <b>HEALTH, SAFETY AND ENVIRONMENT (HSE) MANAGEMENT</b>	PC-183 / E / 8001 /S-V	0	
		DOC. NO.	REV.	
		Page 18 of 18		

Actual work start Date:  
Project:  
Name of the Contractor:  
Name of work:

For the Month of:  
Report No:  
Status as on:  
Name of safety officer:

ITEM	THIS MONTH	CUMMULATIVE
Total Strength (Staff + Workmen)		
Number of HSE meetings organized at site		
Number of HSE awareness programs conducted at site		
Whether workmen compensation policy taken		
Whether workmen compensation policy is valid		
Whether workmen registered under ESI Act		
No. of fatal accidents		
Number of Loss time accidents(other than fatal)		
Other accidents (Non Loss Time)		
Total No. of Accidents		
Total man-hours worked		
Man-hour loss due to fire and accidents		
Compensation cases raised with Insurance		
Compensation cases resolved and paid to workmen		
Remarks		

Date:

**Safety Officer / Resident Engineer**

(Signature and name)

To:

OWNER..... 1 Copy

RCM/SITE-IN-Charge (CONSULTANT) 1 Copy



**PROJECTS & DEVELOPMENT INDIA LTD.**

PC183-TS-8001

0

DOCUMENT NO.

REV.

SHEET 1 OF 43

**TECHNICAL SPECIFICATION**  
**FOR**  
**ELECTRICAL WORKS (SUPPLY & ERECTION)**  
**FOR**  
**ALTERNATE POWER SUPPLY ARRANGEMENT OF**  
**VIKARMPUR GUEST HOUSE**  
  
**TALCHER FERTILISER LIMITED, TALCHER, ODISHA**

REV.	REV. DATE	EFF. DATE	PURPOSE	PREPD.	REVWD.	APPD.
0	25.05.2021	25.05.2021	ISSUED FOR TENDER	RK	SKB	SKB

	<b>TECHNICAL SPECIFICATION FOR ELECTRICAL WORKS (SUPPLY &amp; ERECTION)</b> <b>ALTERNATE POWER SUPPLY ARRANGEMENT OF VIKARMPUR GUEST HOUSE</b> <b>TALCHER FERTILISER LIMITED, TALCHER</b>	PC183-TS-8001	0
		DOCUMENT NO.	REV.
		SHEET 2 OF 43	

CONTENTS

SECTION NUMBER	Clause No.	DESCRIPTION
1.0	1.0	Scope
	2.0	Operating requirement
	3.0	Reference Standard
	4.0	Service Condition
	5.0	Instruction to Bidder
	6.0	Power Supply Distribution
	7.0	Materials
	8.0	Lighting wire
	9.0	Mounting structure
	10.0	Earthing & Lightning protection
	11.0	Tests & Inspection
	12.0	Erection, Testing & Commissioning
	13.0	Make of Components
	14.0	Painting
	15.0	Drawings & Documents
	16.0	Co-ordination with others
	17.0	Handing over to owner
	18.0	Spare Parts
	19.0	Schedule
	20.0	Deviations
	Annexure-I	Drawings & Documents Schedule
	Annexure-II	Make of Equipments / Components
	--	SS & TP of Transformers, HT Power Cables, LT Power & Control cable, Lighting Fixture & Accessories etc.
2.0	--	Equipment Specifications
3.0	--	Erection Testing & Commissioning specification

	<b>TECHNICAL SPECIFICATION FOR ELECTRICAL WORKS (SUPPLY &amp; ERECTION) ALTERNATE POWER SUPPLY ARRANGEMENT OF VIKARMPUR GUEST HOUSE TALCHER FERTILISER LIMITED, TALCHER</b>	PC183-TS-8001	0
		DOCUMENT NO.	REV.
		SHEET 3 OF 43	

**LIST OF ATTACHMENTS**

ATTACHMENT NUMBER	DESCRIPTION
ES: 8043	Engineering Standard - Power Transformers
ES: 8160	Engineering Standard - Cables
PDS: E 601	General Notes on Earthing and Lightning Protection
PDS: E 603	Arrangement of connections of Earth Conductors
PDS: E 604	Typical Details of connections in Earth Pit
PDS: E 605	Earth pit details
PDS: E 610	3.8 M G.I. Electrode for Earthing
PDS: E 611	GI / Al Accessories for Earth Pit
PDS: E 617	Typical Arrangement for Neutral Earthing and Equipment Earthing

 पी डी आई एल <b>PDIL</b>	<b>TECHNICAL SPECIFICATION FOR ELECTRICAL WORKS (SUPPLY &amp; ERECTION) ALTERNATE POWER SUPPLY ARRANGEMENT OF VIKARMPUR GUEST HOUSE TALCHER FERTILISER LIMITED, TALCHER</b>	PC183-TS-8001	0
		DOCUMENT NO.	REV.
		SHEET 4 OF 43	

**SECTION – 1.0  
GENERAL SPECIFICATION**

	<b>TECHNICAL SPECIFICATION FOR ELECTRICAL WORKS (SUPPLY &amp; ERECTION) ALTERNATE POWER SUPPLY ARRANGEMENT OF VIKARMPUR GUEST HOUSE TALCHER FERTILISER LIMITED, TALCHER</b>	PC183-TS-8001	0
		DOCUMENT NO.	REV.
		SHEET 5 OF 43	

## 1.0 SCOPE

- 1.1 The scope covers technical requirement of Supply, Installation, Testing and Commissioning, delivery FOR site in well packed condition of the electrical equipments and accessories specified herein required for electrical works for Alternate Power Supply Arrangement of Vikarpur Guest House for TFL, Talcher, Odisha.
- 1.2 The scope shall include broadly include but not limited to supply, installation, testing & commissioning of following:
- Transformers
  - HT Power Cables
  - LT Power cables, LT Control cables
  - Earthing
  - Civil Job
- 1.3 Any other items not specified but required for the safe operation of the system are also included in vendor's scope of work.
- 1.4 Incoming power supply shall be tapped from the Existing 11 kV Switchboard at 132 kV Switchyard Substation and terminated to 415 V Main Power Distribution Board MPDB through 11/0.433 kV Transformers in New Substation at Vikrampur Guest House.
- 1.5 The scope of work shall also include digging of earth and refilling for directly buried cables in cable protection GI Pipes, earth strips, earth pits, civil works such as making earth pit inspection chambers with covers, grouting of equipment base plate, channels, supports and foundation bolts, chipping of concrete or in brick work for earth strips, pipes or other minor chipping for foundation preparation, if required, cutting holes in walls for sealing of cable entries and making good the same after installation of the equipment and levelling, and other minor similar jobs as per directions of Owner / Engineer-in-Charge.
- 1.6 Quantities indicated in the Schedule of Rates (SOR) are approximate and these may increase or decrease or some items may even be deleted at the time of actual execution.
- 1.7 All civil work (like cutting, chipping, grouting, making opening in floor / wall etc. for equipment foundation and cabling work) pertaining to electrical equipment are in the scope of work of the contractor.
- 1.8 The contractor shall obtain the necessary clearance from local supply authority and electrical inspector of Odisha as applicable, for complete electrical installation. All necessary drawings, calculations, test certificates and record of site tests etc. as required by the Inspector shall be furnished. Any modification/rectification as required by Electrical Inspector shall be carried out free of cost by the contractor. All fees payable to the Supply Company and Electrical Inspector for such service connections shall be paid by the owner.
- 1.9 This specification shall be read in conjunction with all referred standards, associated drawings, specification sheets, PDS and Schedule of Rates (SOR) for Electrical Supply & Erection Works for Alternate Power Supply Arrangement of Vikarpur Guest House (Doc. No. PC183- SOR-8001).
- 1.10 In case of any discrepancies between Technical Specification and SOR in respect of description of equipment / work, the details indicated in the SOR shall prevail.
- 1.11 The contractor shall have valid Electrical licence. The contractor must have PF & ESI codes covering all persons hired by him for carrying out the job. He shall engage suitably skilled / licensed workmen of various categories for execution of work supervised by supervisors / engineer of appropriate qualification and experience to ensure suitable quality of work.



	<b>TECHNICAL SPECIFICATION FOR ELECTRICAL WORKS (SUPPLY &amp; ERECTION) ALTERNATE POWER SUPPLY ARRANGEMENT OF VIKARMPUR GUEST HOUSE TALCHER FERTILISER LIMITED, TALCHER</b>	PC183-TS-8001	0
		DOCUMENT NO.	REV.
		SHEET 6 OF 43	

1.12 The contractor shall observe safety rules and take all necessary safety precautions to carry out the internal electrification work.

1.13 In case of contradiction / conflict among documents or with statutory requirement, Contractor shall refer to Owner for clarification. However, most stringent specification shall be followed with Owner's approval. Owner decision shall be considered as final.

## 2.0 OPERATING REQUIREMENTS

2.1 All equipment and accessories shall be suitable for trouble free and continuous service at their rated capacity in the specified ambient and system conditions.

## 3.0 REFERENCE STANDARDS

3.1 All electrical equipment and installation shall comply with the requirements laid down in the latest issue of relevant Indian Standard Specifications and statutory acts / rules / regulations. In the absence of IS for any particular equipment or in case of imported equipment, relevant IEC Standards shall be applicable. All Specifications, publications mean the latest edition.

3.2 The equipment and installation shall also comply with the provisions of latest issue of Indian Electricity Rules. Contractor shall obtain approvals of Statutory Authorities for equipment and complete installation and shall make, wherever necessary, suitable modification in the equipment, installation to comply with the above.

3.3 Wherever any requirement, laid down in this standard, differs from that in Indian Standard Specification, the requirement specified herein shall prevail.

## 4.0 SERVICE CONDITIONS

The equipment shall be designed for the following site conditions: -

- Maximum ambient temperature - 46 °C
- Minimum ambient temperature - 1 °C
- Design reference temperature - 50 °C
- Relative humidity - 100%
- Altitude above sea level - <1000 mtr

## 5.0 INSTRUCTION TO THE BIDDER

5.1 This specification covers for Alternate Power Supply Arrangement of Vikarmpur Guest House with Transformer, HT Cables, LT cables & wires, earthing, civil job etc as specified in technical specification, SOR, and attachments enclosed with it.

5.2 Complete work shall be carried out conforming to the provisions of Indian Electricity Act and relevant Indian standard Specifications (ISS). Wherever these regulations are supplemented by the State Electricity Dept., Electricity Undertakings / Boards, the installation shall also comply with these requirements. Wherever the specifications given in this NIT differs from those of the statutory regulations, these specifications shall be followed.

5.3 Contractor shall submit the sample of the electrical equipments / items for the approval of Engineer-in-charge before procurement of any of the electrical equipments / items.

5.4 Bidder shall submit various drawings and documents as per Annexure-I 'Drawings and Documents Schedule' for owner's approval before proceeding with the installation works. Approval of drawings / documents does not relieve the contractor of his responsibilities to meet the intents of specifications. Cutting chases / groove, wherever required, and making good is deemed to be included in the contractor's quoted rates.

5.5 Location of Transformers, earth pits etc. shall be marked at site by the contractor and approval of Engineer-in-charge shall be obtained before proceeding with the installation work.

	<b>TECHNICAL SPECIFICATION FOR ELECTRICAL WORKS (SUPPLY &amp; ERECTION) ALTERNATE POWER SUPPLY ARRANGEMENT OF VIKARMPUR GUEST HOUSE TALCHER FERTILISER LIMITED, TALCHER</b>	PC183-TS-8001	0
		DOCUMENT NO.	REV.
		SHEET 7 OF 43	

- 5.6 On completion of works, wiring diagram for complete installation and various Layout drawings as per Drawings and Documents Schedule shall be prepared by the contractor and 4 copies of the same shall be supplied to the owner (M/s TFL) for their record.
- 5.7 Rated Power, Voltage and frequency of supply of current consuming devices and materials used in installation shall be suitable for the power and frequency of the supply to which these are to be connected.
- 6.0 POWER SUPPLY DISTRIBUTION**
- 6.1 Incoming power supply shall be tapped from the Existing 11 kV Switchboard at 132 kV Switchyard Substation and terminated to 415 V Main Power Distribution Board MPDB through 11/0.433 kV Transformers in New Substation at Vikrampur Guest House.
- 7.0 MATERIALS**
- 7.1 The cable shall be of XLPE insulated and of approved make / grade ISI marked. All materials for fittings / accessories, cable etc. to be incorporated in this work shall strictly comply with latest appropriate Indian Standards. If Indian standards have not been issued relevant current British Standards may be used. Aluminium link clips of width 6 mm to 8 mm shall be acceptable without any price adjustment.
- 7.2 The rates for point wiring (power / light) are with the provision of stranded copper conductor of solid drawn copper conductor.
- 8.0 LIGHTING WIRES**
- 8.1 The wires for wiring in lighting system shall be 650 / 1100 V, PVC insulated, unarmoured with stranded copper conductors, unless otherwise specified. The wires shall conform to IS: 694.
- 8.2 The minimum area of conductors shall be 2.5 sq. mm for light point.
- 8.3 The PVC insulation shall be coloured red, yellow, blue for R, Y, B phase and black for neutral.
- 9.0 MOUNTING STRUCTURES**
- Transformer etc shall be mounted / supported on suitable structure fabricated out of standard sections of mild steel, i.e. channels, angels, flats etc conforming to IS: 2062.
- 10.0 EARTHING & LIGHTNING PROTECTION**
- 10.1 Complete earthing installation shall be done as per IS: 3043 and lightning protection shall be as per IS/IEC 62305 along with its latest amendments.
- 10.2 Earthing & lightning protection shall also conform with the requirements of National building code.
- 10.3 Separate Earthing rings for Earthing & Lightning protection shall be provided. Minimum size of main grid shall be 50mmX6mm.
- 10.4 Earthing ring shall comprise of buried GI earth strips and GI pipes/electrodes. All these earth electrodes shall be inter-connected.
- 10.5 Individual electrical equipment shall be earthed by GI strip. Earth buses shall be provided for earthing groups of electrical/non-electrical equipment to earthing grid/rings.
- 10.6 All equipment rated above 250V shall have two external earth connections and those rated up to 250V shall have one external earth connection.
- 10.7 All GI conductors shall meet the galvanizing requirement as per IS.
- 10.8 Surplus soil shall be carried away to distance exceeding 50 m and the site left clean and tidy.

	<b>TECHNICAL SPECIFICATION FOR ELECTRICAL WORKS (SUPPLY &amp; ERECTION)</b> <b>ALTERNATE POWER SUPPLY ARRANGEMENT OF VIKARMPUR GUEST HOUSE</b> <b>TALCHER FERTILISER LIMITED, TALCHER</b>	PC183-TS-8001	0
		DOCUMENT NO.	REV.
		SHEET 8 OF 43	

## 11.0 TESTS & INSPECTION

- 11.1 All equipment shall be routine tested as per relevant standards in presence of owner representative at manufacturer's works before despatch. In addition, the equipment shall be inspected at site for final acceptance.
- 11.2 Electrical installation work shall be subjected to inspection by owner/ his authorised representative, statutory bodies like Electrical Inspector. The contractor shall carry out without extra cost to owner rectifications / modifications desired by the above authorities to make the installation conforming to I.E. Rules etc.
- 11.3 The owner may reject any portion of the work considered defective or of poor workmanship and the contractor shall make good these defects without extra cost to owner.
- 11.4 Guarantee / Warrantee Certificate for all electrical equipments / appliances / components shall be handed over to the owner / Engineer-in-charge.
- 11.5 All equipment shall be routine tested as per relevant standards in presence of owner representative at manufacturer's works before despatch. In addition, the equipment shall be inspected at site for final acceptance.
- 11.6 The following tests as specified in IS-732, code of practice for electric wiring and fittings in building shall be complied with before the complete installation is taken over. The contractor shall carry out the tests in the presence of Engineer-in-charge. Electrical wiring test sheet shall be signed both by the contractor's representative and the Engineer-in-charge. All testing equipment shall be arranged by contractor without any extra cost.
- a) Insulation resistance shall be measured by 500 volts megger. The insulation resistance in mega ohm of the installation shall not be less than 50 divided by the number of points on the circuit and the resistance of the whole installation shall not exceed one ohm and resistance including earth mass as 5 ohm.
- b) Testing Polarity of Switches
- A test shall be made to verify that all non linked single pole switches have been fitted in the same conductor throughout and that such conductor has been connected to another or phase conductor or to the non-earthed conductor of the supply.

## 12.0 ERECTION, TESTING & COMMISSIONING

- 12.1 The contractor shall undertake erection of all equipment in accordance with good engineering practices in conformity with statutory regulations and Code of Practice and to the entire satisfaction of the owner.
- 12.2 Contractor shall supply 'as built drawings' for complete installation.
- 12.3 The contractor shall arrange all the necessary erection tools, tackles, testing and measuring instruments and shall supply erection materials and consumables.
- 12.4 The contractor shall clear the site after commissioning of the equipments / system and obtain the Site Clearance Certificate from owner's Engineer-in-charge.

## 13.0 MAKE OF COMPONENTS

- 13.1 Make of equipment / components shall be as per Annexure-II. Make of equipment / components not indicated shall be subject to owner's approval.

## 14.0 PAINTING

- 14.1 The equipment surface to be painted shall be pre-treated to remove all dust, scale and foreign adhering matter by suitable treatment.
- 14.2 All metal surfaces shall be painted with two coats of suitable anti-rust paint followed by two coats of anticorrosive epoxy paints.

	<b>TECHNICAL SPECIFICATION FOR ELECTRICAL WORKS (SUPPLY &amp; ERECTION) ALTERNATE POWER SUPPLY ARRANGEMENT OF VIKARMPUR GUEST HOUSE TALCHER FERTILISER LIMITED, TALCHER</b>	PC183-TS-8001	0
		DOCUMENT NO.	REV.
		SHEET 9 OF 43	

- 14.3 All paints shall be carefully selected to withstand tropical heat and extremes of weather. The paint shall not scale off, crinkle or be removed by abrasion due to normal handling.
- 14.4 Unless otherwise specified, the finishing shade shall be light gray having No.631 as per IS-5.
- 15.0 DRAWINGS AND DOCUMENTS**
- 15.1 The bidder shall supply the drawings and documents as per Annexure-I 'Drawings & Documents Schedule'.
- 15.2 All drawings and documents shall have the following descriptions written boldly:
- Name of Client.
  - Name of Consultant i.e. PDIL.
  - Enquiry / Order Number with Project/Plant name.
  - Equipment Code No. and Description.
- 15.3 The Contractor shall be responsible for preparation and submission of two sets of drawings viz.  
(1) "AS BUILT" (2) Material Reconciliation and Deviation Statement
- 15.4 The vendor may furnish a Bill of Materials covered in their offer. However, this shall be treated for information only and shall not absolve them from his obligation to supply the required items and quantities for making the plant complete as per intent of the specification.
- 15.5 Drawings and documents shall be submitted as per Annexure-I
- 16.0 CO-ORDINATION WITH OTHERS**
- 16.1 The contractor shall co-ordinate with owner's other contractors / agencies as required.
- 17.0 HANDING OVER TO OWNER**
- 17.1 The contractor shall hand over the complete installation as a whole. Minor works not specified or mentioned in the scope or SOR but required to complete the job as a whole will have to be done by the contractor without extra cost. Any equipment / installation shall not be deemed as handed over to Owner until the same is complete in all respect and is accepted in writing by the Owner / Engineer-in-charge.
- 18.0 SPARE PARTS**
- 18.1 Commissioning spares as required shall be supplied without any extra cost to the owner.
- 19.0 SCHEDULE**
- 19.1 Bidder shall furnish bar chart for complete scope of their works.
- 20.0 DEVIATIONS**
- 20.1 Clause-wise deviations, if any, from this specification shall be clearly indicated in the offer with reasoning.

	<b>TECHNICAL SPECIFICATION FOR ELECTRICAL WORKS (SUPPLY &amp; ERECTION) ALTERNATE POWER SUPPLY ARRANGEMENT OF VIKARMPUR GUEST HOUSE TALCHER FERTILISER LIMITED, TALCHER</b>	PC183-TS-8001	0
		DOCUMENT NO.	REV.
		SHEET 10 OF 43	

**ANNEXURE-I**

**DRAWINGS AND DOCUMENTS SCHEDULE**

Sl. No.	Description	With bid Y/N	For approval	For Information	Final / Approved / As built
1.	Specification Sheets, duly completed	N	Y	--	Y
2.	Technical Particulars, duly filled in	N	Y	--	Y
3.	Dimensional drawing for complete Transformer, Marshalling Box, disconnecting chamber, terminal chambers etc.	N	Y	--	Y
4.	Schematic and Wiring Diagram for Transformer	N	Y	--	Y
5.	Terminal arrangement drawing for Transformer	N	Y	--	Y
6.	Document of Cables	N	Y	--	Y
7.	Bill of Materials (as built)	N	--	Y	Y
8.	Installation, Operation & Maintenance Manual	N	--	Y	Y
9.	Illustrative and Descriptive Literature/ Catalogue	N	--	Y	Y
10.	Installation, Termination and Jointing Instructions	N	--	--	Y
11.	Sketch showing mounting arrangement of Lighting Fixtures with dimensions.	N	--	Y	Y
12.	Catalogue of brought out items	N	--	Y	Y
13.	List of spares with identification marks	N	Y	--	Y
14.	Type Test Certificates of similar equipment a) Transformers b) Cables	N	--	--	Y
15.	Routine Test Certificates	N	--	--	Y
16.	Guarantee/Warrantee Certificates	N	--	--	Y

**Note:**

- 2 hard copies & 1 soft copy shall be supplied for approval/information.
- 4 hard copies & 2 soft copies in Pen Drive shall be submitted as final documents. These shall be made in sets and supplied in fine plastic coated folder.

**Y – Yes, N – No**

	<b>TECHNICAL SPECIFICATION FOR ELECTRICAL WORKS (SUPPLY &amp; ERECTION)</b> <b>ALTERNATE POWER SUPPLY ARRANGEMENT OF VIKARMPUR GUEST HOUSE</b> <b>TALCHER FERTILISER LIMITED, TALCHER</b>	PC183-TS-8001	0
		DOCUMENT NO.	REV.
		SHEET 11 OF 43	

**ANNEXURE-II**  
**MAKE OF EQUIPMENTS / COMPONENTS**

Sl. No.	ITEM	MAKE
1.	Transformer	Alstom Limited ( Areva T & D)
		Crompton Greaves Ltd
		Emco Limited
		Bharat Bijlee Ltd
		Kirloskar Electric Company Ltd.
		Voltamp Transformers Ltd.
2.	HT Power Cable	Cable Corpn. of India Limited
		Ravin Cables Ltd.
		KEC International Ltd. (Formerly RPG Cables Limited)
		KEI Industries Ltd.
		NICCO Corporation Ltd.
		Torrent Cables Ltd.
		Universal Cables Ltd.
		APAR Industries Ltd. (Unit: Uniflex cable)
3.	LT Power Cable	Ravin Cables Ltd.
		KEC International Ltd. (Formerly RPG Cables Limited)
		KEI Industries Ltd.
		NICCO Corporation Ltd.
		Torrent Cables Ltd.
		Universal Cables Ltd.
		APAR Industries Ltd. (Unit: Uniflex cable)
4.	Control Cable	Ravin Cables Ltd.
		KEC International Ltd. (Formerly RPG Cables Limited)
		KEI Industries Ltd.
		NICCO Corporation Ltd.
		Torrent Cables Ltd.
		Universal Cables Ltd.
		APAR Industries Ltd. (Unit: Uniflex cable)
5.	Earthing Cable	Finolex Cables Ltd.
		NETCO cable Industries (Pvt.) Ltd.
		KEI Industries Ltd.
		NICCO Corporation Ltd.
		TC Communication Pvt.Ltd.
		Universal Cables Ltd.
6.	Copper Wires-650/1100 Volts (Flexible Cable)	Anchor Electricals Pvt. Ltd.
		Finolex Cables Ltd.
		Havells India Ltd.
		NICCO Corporation Ltd.
		Plaza Cable Industries Ltd.
		Polycab Wires & Cables

	<b>TECHNICAL SPECIFICATION FOR ELECTRICAL WORKS (SUPPLY &amp; ERECTION) ALTERNATE POWER SUPPLY ARRANGEMENT OF VIKARMPUR GUEST HOUSE TALCHER FERTILISER LIMITED, TALCHER</b>	PC183-TS-8001	0
		DOCUMENT NO.	REV.
		SHEET 12 OF 43	

Sl. No.	ITEM	MAKE
7.	Industrial Cable Gland	Baliga Lighting Equipments Limited Comet Brass Products Comet Industries Dowell's Electricals Electromac Industries FCG Flameproof Control Gears Pvt. Ltd. Gland-Mech. Industries Power Engg. Co. Quality & Precision Indl. Equipment S J Metal Industries (Jainson)
8.	Cable Lugs	Dowell's Electricals Forward Engg. Industries KSE Electrical Pvt. Ltd. Power Engg. Co. S J Metal Industries (Jainson) Usha Martin Industries Ltd. (Isma Divn.)
9.	PVC Conduit Pipes	A.K.G. Finolex Industries Ltd. Kalinga Cables & Conduit Co. Plaza Cable Industries Ltd. Polypack Prakash Industries Ltd.
10.	Lighting Fittings & Accessories / LED Lamp	Bajaj Electrical Ltd. Crompton Greaves Ltd. Havells India Ltd. Philips India Ltd. Wipro Lighting
11.	Earthing & Lighting Protection Material	Bharti Exports Indmark Formtech Pvt. Ltd. Jamna Metal Company Jayant Metal Mfg Co. Mahavir Industrial Corporation Metalite Industries Metropolitan Industries Premier Power Products (Calcutta) Pvt. Ltd. Rukmini Electricals & Components Pvt. Ltd. Sadhana Engineering Corporation Sai Galvanisers & Fabricators Pvt. Ltd. Stealite Engg. Co.
12.	GI Pipes	Bharti Exports Indian Tube Co. (Tata Div. Of Tubes & Pipes) Jindal Pipes Ltd. Meghijot Enterprises



	<b>TECHNICAL SPECIFICATION FOR ELECTRICAL WORKS (SUPPLY &amp; ERECTION)</b> <b>ALTERNATE POWER SUPPLY ARRANGEMENT OF VIKARMPUR GUEST HOUSE</b> <b>TALCHER FERTILISER LIMITED, TALCHER</b>	PC183-TS-8001	0
		DOCUMENT NO.	REV.
		SHEET 13 OF 43	

SI. No.	ITEM	MAKE
		Rukmini Electricals & Components Pvt. Ltd.
		Steelcraft
41	HT Cable Termination Kit / Joining Kit	Raychem

NOTE: Items not covered above shall be subject to Owner/ Consultant's approval.

	<b>TECHNICAL SPECIFICATION FOR ELECTRICAL WORKS (SUPPLY &amp; ERECTION) ALTERNATE POWER SUPPLY ARRANGEMENT OF VIKARMPUR GUEST HOUSE TALCHER FERTILISER LIMITED, TALCHER</b>	PC183-TS-8001	0
		DOCUMENT NO.	REV.
		SHEET 14 OF 43	

**SECTION – 2.0**  
**EQUIPMENT SPECIFICATION**

	<b>TECHNICAL SPECIFICATION FOR ELECTRICAL WORKS (SUPPLY &amp; ERECTION) ALTERNATE POWER SUPPLY ARRANGEMENT OF VIKARMPUR GUEST HOUSE TALCHER FERTILISER LIMITED, TALCHER</b>	PC183-TS-8001	0
		DOCUMENT NO.	REV.
		SHEET 15 OF 43	

## 1.0 GENERAL

- 1.1 Equipment to be supplied by the contractor shall conform to relevant Indian Standards, Engineering Standards, Specification Sheets & Drawings enclosed.
- 1.2 Equipment shall also comply with the requirement of Statutory Acts, Rules & Regulations.
- 1.3 Make of the equipment / components shall be as specified elsewhere in this specification. Make of the equipment / components not indicated shall be subject to owner/ consultant's approval.
- 1.4 Drawings & Documents for various equipments as indicated in respective Engineering Standards shall be furnished. For other equipments, GA drawings & descriptive catalogues shall be furnished.
- 1.5 The electrical equipment and their installation shall also comply with the requirement of

## 2.0 EQUIPMENT SPECIFICATIONS

### 2.1 TRANSFORMER

- 2.1.1 The transformer shall be double wound, copper conductor, Dyn11 type. Transformer shall have 11 KV primary windings. Transformer shall also conform to the specification sheet (attached in this specification). Transformer shall have energy efficiency of Level 2.
- 2.1.2 The transformers shall have 'OFF' load tap changers.
- 2.1.3 Make of the all bought out items such as Buchholz relay, Oil Temperature Indicator, Winding Temperature Indicator, Magnetic Oil Level Gauge, Bushings etc. shall be indicated by the bidder and shall be subject to the owner / consultant for approval.
- 2.1.4 Current rating of bushings shall be at least 1.5 times the full load current subject to a minimum of 400A.
- 2.1.5 Neutral bushing shall be of same voltage grade as that of phase.
- 2.1.6 Bushing and support insulators shall be suitable for highly polluted area with creepage distance of 31mm / kV.
- 2.1.7 Fittings and additional fittings as mentioned in Engineering Standard (ES: 8043) and Specification Sheet shall be provided.
- 2.1.8 Transformer cable boxes shall be dust, vermin and weather proof type with IP-55 degree of protection.
- 2.1.9 HV & LV Cable Terminal Box enclosure shall have provision for Earthing at two distinct points.
- 2.1.10 All gaskets joints for transformer body Earthing shall be provided with continuity conductor (GI / Al strip) to electrically connect the transformer body.
- 2.1.11 Top & Bottom Oil sampling valve shall be provided in each transformer.
- 2.1.12 Conservator shall be Air cell type.
- 2.1.13 Oil level Glass gauge shall be provided on conservator.
- 2.1.14 Bus Bar (if used) shall be of tinned copper.
- 2.1.15 Magnetic Oil Level Gauge with alarm and trip contacts shall be provided in each transformer.
- 2.1.16 Radiator Vacuum withstand capacity shall be designed as per Cl. No. 6.2.1 of ES: 8043.
- 2.1.17 The marshalling box shall also consist of following:
  - a) 240V AC Space heater with thermostat.
  - b) Door switch operated lighting fixture suitable for 240V AC.

	<b>TECHNICAL SPECIFICATION FOR ELECTRICAL WORKS (SUPPLY &amp; ERECTION) ALTERNATE POWER SUPPLY ARRANGEMENT OF VIKARMPUR GUEST HOUSE TALCHER FERTILISER LIMITED, TALCHER</b>	PC183-TS-8001	0
		DOCUMENT NO.	REV.
		SHEET 16 OF 43	

- c) The box shall have a lockable door.
- d) The complete drawing of the marshalling box wiring diagram shall be provided inside the marshalling box on SS plate.
- e) Isolation switch for 240V, 50Hz shall be

- 2.1.18 Main transformer, conservator, piping, radiators, marshalling box, cable boxes, supports etc. shall have uniform shade of painting.
- 2.1.19 Arrangement of marshalling box shall be such that its front face is always being visible from front side.
- 2.1.20 Analog OTI / WTI against dial type for all transformers shall be provided.
- 2.1.21 Bidder to provide CT for WTI which shall be installed in tank.
- 2.1.22 Stand-by Earth Fault CT 5P10 for all transformers shall be provided in transformer neutral by the bidder.
- 2.1.23 Equalizer pipe and PRV Vent shall be provided for the transformer.
- 2.1.24 Cable box / tank top cover shall be provided with slope / canopy. Cable box shall be suitable for termination of XLPE insulated cable through heat shrinkable Raychem kit.
- 2.1.25 High grade Cold Roll Grain Oriented sheet steel shall be used for transformer core.
- 2.1.26 Proper supporting arrangement shall be provided for LV & HV cable terminal box.
- 2.1.27 Aluminium foil wound transformer shall not be acceptable.
- 2.1.28 For detailed specification refer Engineering Standard of Power Transformers (ES: 8043).

## 2.2 Cables

- 2.2.1 Cables shall conform to Engineering Standard ES-8160 and enclosed Specification Sheets.
- 2.2.2 All HT power cables shall be with stranded aluminium with XLPE insulation, PVC inner sheathed, armoured, PVC outer sheathed FRLS type and construction as per IS: 7098 (Part 2) and as specified in the specification Sheet (attached in this specification)
- 2.2.3 All LT power cables shall be with stranded aluminium / copper conductor with XLPE insulation, PVC inner sheathed, armoured, PVC outer sheathed FRLS type and construction as per IS: 7098 (Part 1) and as specified in the specification Sheet (attached in this specification).
- 2.2.4 All control cables shall be stranded copper conductor with XLPE insulation, PVC inner sheathed, armoured, PVC outer sheathed FRLS type and construction as per IS: 7098 (Part 1) and as specified in the specification Sheet (attached in this specification).
- 2.2.5 All control cables cores shall be identified with numerical core numbers printed on core instead of colours.
- 2.2.6 All cables shall be armoured and shall have extruded inner and outer sheath. Cables shall be in continuous lengths without any joints.
- 2.2.7 Preferred drum length shall be indicated by bidder which shall be subject to approval by Owner/PDIL. Bidder shall indicate maximum drum length for each size and type of cables.
- 2.2.8 Various sizes of cables and their quantities shall be as indicated in the SOR. The quantities indicated are tentative and may increase or decrease. Some sizes may be even deleted. Exact requirement shall be indicated at the time of order. Bidder shall confirm that there shall be no variation of unit rate on this account.

	<b>TECHNICAL SPECIFICATION FOR ELECTRICAL WORKS (SUPPLY &amp; ERECTION) ALTERNATE POWER SUPPLY ARRANGEMENT OF VIKARMPUR GUEST HOUSE TALCHER FERTILISER LIMITED, TALCHER</b>	PC183-TS-8001	0
		DOCUMENT NO.	REV.
		SHEET 17 OF 43	

- 2.2.9 Technical Particulars shall be filled by bidder and submitted for approval after order in line with PO requirement before commencement of manufacturing. Separate sheet shall be furnished for different grade cables.
- 2.2.10 PVC compound used for inner/outer sheath shall have reduced flame propagation property.
- 2.2.11 Thickness of insulation, inner sheath, outer sheath and dimensions of armour wire/strip shall be as per IS: 7098.
- 2.2.12 The design and construction of the cables shall meet the requirements of severe fault level.
- 2.2.13 The cables shall be new and specifically produced against the order.
- 2.2.14 Cable conductor shall be clean, reasonably uniform in size and shape, smooth and free from harmful defects. Aluminium cables shall have aluminium conductor of grade H4 and copper cables shall have copper conductor of high conductivity as per IS: 8130.
- 2.2.15 Conductor screening shall be provided over the conductor by extrusion of non-metallic semiconducting compound, which shall be compatible with the insulating material and suitable for the operating temperature of the cable. The conductor after screening shall be provided with cross linked polyethylene (XLPE) insulation and semiconductor screen on insulation applied by triple extrusion.
- 2.2.16 Insulation screening in two parts, namely non-metallic and metallic shall be applied over the XLPE insulation. Non-metallic part shall be applied directly over the insulation of each core and shall consist of semi-conducting tape or extruded semi conducting compound or a combination of two or either material with a semi-conducting coating.
- 2.2.17 The non-magnetic metallic part shall consist of either tape, or braid or a sheath of copper and shall be applied over the non-metallic part.
- 2.2.18 For multi-core HT cable the minimum bend radius shall be  $15 \times D$ . For single core cable minimum bend radius shall be  $15 \times D$ . For LV multicore cables minimum bending radius shall be  $12D$
- 2.2.19 HT Cables should be manufactured by dry curing (N<sub>2</sub> gas) process.
- 2.2.20 Cables shall be suitable for operation at a power frequency voltage 10% higher than rated voltage.
- 2.2.21 No negative tolerance shall be accepted in length of cable/drum length offered for all HT & LT cables.
- 2.2.22 The cut ends of cable shall be sealed by means of non-hygroscopic sealing material.
- 2.2.23 Following information shall be embossed on outer sheath throughout the length of cable at regular interval:
- i) Cable size & no of cores
  - ii) IS specification (IS-7098)
  - iii) Voltage grade
  - iv) Type of insulation
  - v) Year of Manufacture
  - vi) Name of Manufacture
  - vii) Running meter
- 2.2.24 Wherever any requirement, laid down in this specification/specification sheet, differs from that in Engineering Standard (ES:8160), the requirements specified in this specification/specification sheet shall prevail.
- 2.2.25 Testing and inspection of the cables shall be as per relevant IS and as per ES: 8160.

	<b>TECHNICAL SPECIFICATION FOR ELECTRICAL WORKS (SUPPLY &amp; ERECTION)</b> <b>ALTERNATE POWER SUPPLY ARRANGEMENT OF VIKARMPUR GUEST HOUSE</b> <b>TALCHER FERTILISER LIMITED, TALCHER</b>	PC183-TS-8001	0
		DOCUMENT NO.	REV.
		SHEET 18 OF 43	

### 2.3 LIGHT FIXTURES

- 2.3.1 All lighting fixtures shall be LED type.
- 2.3.2 The fixtures shall be complete with all accessories including the driver, lamps and all accessories. The lighting fixtures shall also conform to the specification sheet (attached in this specification).
- 2.3.3 The fixtures shall be provided with cable glands and a terminal block suitable for termination of copper conductor up to 2.5 sq. mm size.
- 2.3.4 The fixture shall be so designed that it shall be possible to maintain or replace different accessories without difficulty, including replacement of lamps

### 3.0 TERMINAL BOXES

- 3.1 In concealed conduit wiring, the terminal point for power / light socket outlets, switching etc. shall terminate in recessed cast iron or galvanized mild steel boxes fitted flush with wall surface. All terminal boxes shall be properly earthed and connected to earth dolly.

### 4.0 LIGHTING POLES, if required

- 4.1 Lighting pole shall be steel tubular swaged type conforming to designation 410 SP-3 as per IS:2713 complete with base plate, threaded stud with nuts & washers for earthing, final taper plug, bracket on the overhang portion for fixing of lighting fixtures bolts, nuts and screws as required shall be provided.
- 4.2 The outer & inner portions of the poles for ground installation shall have bituminous compound coating at the bottom after galvanising.
- 4.3 Zinc coating shall be done by hot dip galvanising process as per IS: 2629 and shall be min. 610 gm / sq. meter.
- 4.4 Foundation depth for 5m and 9 m pole shall be 1250mm and 1500mm respectively as per relevant IS.
- 4.5 The poles shall be subjected to min. following tests:
- Thickness of galvanising (min. 80 microns)
  - Drop test as per IS: 2713.
  - Deflection test as per IS: 2713

	<b>TECHNICAL SPECIFICATION FOR ELECTRICAL WORKS (SUPPLY &amp; ERECTION) ALTERNATE POWER SUPPLY ARRANGEMENT OF VIKARMPUR GUEST HOUSE TALCHER FERTILISER LIMITED, TALCHER</b>	PC183-TS-8001	0
		DOCUMENT NO.	REV.
		SHEET 19 OF 43	

**SPECIFICATION SHEET  
11 / 0.433 KV TRANSFORMERS**

PROJECT: Coal Based Fertilizer Plant		PLANT: Alternate Power to Vikrampur Guest House	
ISSUED FOR : PROPOSAL <input type="checkbox"/>		ENQUIRY <input checked="" type="checkbox"/>	
		ORDER <input type="checkbox"/>	
		FINAL <input type="checkbox"/>	
<b>GENERAL</b>			
Item No. :	Ref. Stds. : IS-1180, IS-2026, IEC-60076		
Quantity :	Encl. Docs. :		
Description : Transformers	Vendor :		
Code No. :	Vendor's Ref. No. :		
TEST TO BE WITNESSED : Routine : <input checked="" type="checkbox"/> Heat Run : <input type="checkbox"/> Impulse : <input type="checkbox"/> Others : <input type="checkbox"/>			
<b>SERVICE CONDITIONS</b>			
<b>SYSTEM DETAILS (PRI. / SEC.)</b>		<b>AMBIENT CONDITIONS</b>	
Nom. Voltage with $\pm$ % : 11KV $\pm$ 10% / 0.433KV $\pm$ 10%		Temp.- Max./Min./Design Ref. : 46 / 1 / 50°C	
Highest System Voltage : 12 / 0.457 KV		Rel. Humidity : 100 %	
Number of phases : 3 Ph / 3 W + N		Alt. above Sea < 1000M	
Rated Frequency with $\pm$ : 50 Hz $\pm$ 5%		<b>Atmospheric Pollution</b>	
Combined V & F Variation : $\pm$ 10 %		Dusts : Coal Dust & Urea Dust	
Fault MVA : 750 MVA / 36 MVA		Vapour : Ammonia & Highly Corrosive	
Earthing Mode : Solidly Earthed		<b>Location</b>	
		Indoor : <input type="checkbox"/> Outdoor : <input checked="" type="checkbox"/>	
<b>AUX. POWER SUPPLY</b>			
		<b>System Data</b>	
		A.C. : 415V $\pm$ 10%, 3P & N, 50Hz $\pm$ 5%	
		D.C. : 110 V	
		<b>Instrument Contact Rating</b>	
		A.C. : 240 V, 5 Amps	
		D.C. : 110 V, 5 Amps	
<b>BASIC DATA</b>			
<b>RATING</b>		<b>TERMINAL CONFIGURATION</b>	
Rated Capacity : 250 KVA		W	
No Load Voltage Ratio : 11 KV / 0.433 KV		X Z	
Highest Voltage for Eqpt. : 12 KV / 0.457 KV		Y	
Insulation level		Shall be provided later.	
Impulse : 75 KV / --			
Pri.-/ Sec			
Power Freq. : 28 KV / 3 KV		<b>TERMINAL CONNECTIONS</b>	
Impedance at 75 ° C: As per IS (without negative tolerance)		<b>PRI.</b>	
Vector Group : Dyn 11			
Cooling System : ONAN		<b>SEC.</b>	
Motor I Start & T Start : -			
<b>TAP CHANGER</b>		<b>Control Cable</b>	
Type of Taps			
On Load : <input type="checkbox"/> Off Ckt. : <input checked="" type="checkbox"/>			
Range of Taps : -5% TO +5%		<b>Earth Conductor</b>	
No. of Taps : 5 @ 2.5 %			
<b>C.T. REQUIREMENTS</b>		<b>Cable Gland Type &amp; Material</b>	
<b>Differential Protection</b>			
3 nos. on Trf. : <input type="checkbox"/>		Primary : } Double Secondary : } compression Control : } Rolled Al	
3 nos. Loose : <input type="checkbox"/>			
<b>Restricted earth fault Protection</b>		<b>PAINTING</b>	
1 no. on Trf. : <input checked="" type="checkbox"/> CI.-PS		Type : EPOXY BASED	
3 nos. Loose : <input type="checkbox"/>		Shade : 631 OF IS : 5	
<b>Standby earth fault Protection</b>		Reqd. : <input type="checkbox"/> For a period of 2 Years	
1 no. on Trf. : <input checked="" type="checkbox"/> CI.-5P10			
<b>ADDITIONAL FITTINGS</b>			
1. LV Neutral terminal box			
2. Thermometer pocket with cover			
3. Tank magnetic oil level gauge			
4. Bi-directional roller			

- All unfilled data shall be filled by the bidder. Completely filled in Specification Sheet duly stamped & signed by the bidder shall be submitted after award of order.

- Impulse test certificate for similar rating shall be furnished after award of order.



	<b>TECHNICAL SPECIFICATION FOR ELECTRICAL WORKS (SUPPLY &amp; ERECTION) ALTERNATE POWER SUPPLY ARRANGEMENT OF VIKARMPUR GUEST HOUSE TALCHER FERTILISER LIMITED, TALCHER</b>	PC183-TS-8001	0
		DOCUMENT NO.	REV.
	SHEET 20 OF 43		

### TECHNICAL PARTICULARS TRANSFORMERS

PROJECT: Coal Based Fertilizer Plant		PLANT: Alternate Power to Vikrampur Guest House	
ISSUED FOR : PROPOSAL <input type="checkbox"/>		ENQUIRY <input checked="" type="checkbox"/>	ORDER <input type="checkbox"/>
		FINAL <input type="checkbox"/>	
<b>GENERAL</b>			
Item no. :			Ref. Stds. :
Quantity :			Make :
Description :			Maker's Type :
Code no. :			
<b>ELECTRICAL DATA</b>			
Rating / Voltage Ratio			
Rated Current - Primary / Secondary			
Rated No Load Current			
Temp. Rise over Ambient - Oil / Winding			
Load Loss at Rated Current at 75° C			
No Load Loss at Rated Voltage / Copper Loss			
Full Load Efficiency at CosΦ - Unity / 0.8 Lag			
Maxm. Efficiency & Load at which it occurs			
Full Load Regulation at CosΦ - Unity / 0.8 Lag			
Short Circuit Withstand Capacity			
B max. at Rated V & F ( Tesla )			
Excitation Loss per Kg. at B max.			
X/R Ratio			
<b>INSULATION</b>	Primary		
<b>GRADED / UNIFORM</b>	Secondary		
Induced Over Voltage Withstand Capacity : Pri / Sec.			
OLTC : Rated Voltage / Rated Current			
Total Auxiliary Power Requirement : AC / DC			
<b>CONTROL PANELS</b>	Sheet Metal Thickness		
	Enclosure Type		
	Control Scheme Ref. No.		
Cooling Fans : Qty. / Rating			
Minimum Clearance : H.V. / L.V.	i. Between phases		
	a. In air mm		
	b. In oil mm		
	ii. Between phase & earth		
	a. In air mm		
	b. In oil mm		
Short-circuit Impedance at 75 o C			
<b>MECHANICAL DATA</b>			
Core : Material & Grade			
Winding Type : Pri. / Sec.			
<b>INSULATING MATERIAL</b>	Between Turns		
	Between Primary & Secondary		
	Between Core & Winding		
<b>RADIATORS</b>	Cooling Tubes / Separate Bank		
	Thickness		
	Vacuum Withstand Capacity		
<b>TANK</b>	Material		
	Thickness : Side / Bottom / Cover		
	Vacuum Withstand Capacity		
	Over Pressure Capacity		
<b>DIMENSIONS</b>	Overall ( LXBXH )		
	Roller C/L		
	Largest Package ( LXBXH )		
Minimum Height required to lift the Core			
<b>WEIGHT</b>	Core & Winding		
	Total		
	Heaviest Package		
Oil Quantity in Litres			
Noise Level			
<b>BUSHING DATA (PRI. / SEC. / NEUTRAL )</b>			
Type & Make			
Ref. Standard			

	<b>TECHNICAL SPECIFICATION FOR ELECTRICAL WORKS (SUPPLY &amp; ERECTION) ALTERNATE POWER SUPPLY ARRANGEMENT OF VIKARMPUR GUEST HOUSE TALCHER FERTILISER LIMITED, TALCHER</b>	PC183-TS-8001	0
		DOCUMENT NO.	REV.
		SHEET 21 OF 43	

Rated Voltage	
Rated Current	
Creepage Distance	
<b>MAKE &amp; TYPE OF BOUGHT OUT ITEMS</b>	
Temperature Indicators : Winding / Oil	
Buchholz Relay / Magnetic Oil Level Gauge	
Cooling Fans / Current Transformers	
OLTC	
Control Panels	
Pressure Release Device	

- Note: Completely filled in separate Technical Particulars Sheet for each type and rating of transformer shall be filled and submitted after award of order for owner/consultant approval before commencement of manufacturing in line with NIT/PO.

	<b>TECHNICAL SPECIFICATION FOR ELECTRICAL WORKS (SUPPLY &amp; ERECTION) ALTERNATE POWER SUPPLY ARRANGEMENT OF VIKARMPUR GUEST HOUSE TALCHER FERTILISER LIMITED, TALCHER</b>	PC183-TS-8001	0
		DOCUMENT NO.	REV.
		SHEET 22 OF 43	

**SPECIFICATION SHEET  
HT CABLES**

PROJECT: Coal Based Fertilizer Plant		PLANT: Alternate Power to Vikrampur Guest House		
ISSUED FOR : PROPOSAL <input type="checkbox"/>		ENQUIRY <input checked="" type="checkbox"/>	ORDER <input type="checkbox"/> FINAL <input type="checkbox"/>	
<b>GENERAL</b>		<b>AMBIENT CONDITION</b>		
Encl. Docs. :		Temp. Max./Min./Design Ref. 46 / 1 / 50°C		
Vendor :		Relative Humidity: 100 %	Alt. above Sea Level < 1000M	
Vendor Ref. No. :		<b>Atmospheric Pollution</b>	Dusts : Coal Dust & Urea Dust Vapour : Ammonia & Highly Corrosive	
<b>TESTS TO BE WITNESSED:</b> Routine <input checked="" type="checkbox"/> Type <input type="checkbox"/> Acceptance <input checked="" type="checkbox"/> Others <input type="checkbox"/>				
Type Tests Certificate of Similar Cable : Required <input checked="" type="checkbox"/> Not required <input type="checkbox"/>				
<b>BASIC DATA</b>				
Item No.	1	2		
Ref. Stds.	IS:7098 (PART-2)			
Voltage Grade	11 KV POWER CABLE			
System Earthing	UE			
Type of Cable	POWER			
<b>CONDUCTOR</b>	ALUMINIUM/ COPPER	ALUMINIUM		
	STRANDED	STRANDED		
Insulation Type		XLPE EXTRUDED		
Inner Sheath Type		EXTRUDED PVC (ST2)		
<b>CONDUCTOR SCREEN</b>	Required	--		
	Not Required	--		
Material of Conductor Screen		AS PER IS		
<b>ARMOURING</b>	Required	YES		
	Material	GALV. STEEL STRIP		
	No. of Layer	SINGLE		
Outer Sheath Type		EXTRUDED FRLS PVC TYPE-ST2		
Special Requirements		INSULATION SCREEN REQUIRED		
Drum Material		STEEL		
<b>BILL OF QUANTITY</b>				
Item No.	No. of Core & Cross-Sectional Area in sq. mm.	Qty. in Mtr.	Preferred Drum Length	Remarks
<b>11 KV XLPE insulated, armoured, FRLS PVC outer sheathed power cable of following sizes:</b>				
1.	3C x 240 sq. mm (Al)	Refer SOR	LATER	

	<b>TECHNICAL SPECIFICATION FOR ELECTRICAL WORKS (SUPPLY &amp; ERECTION)</b> <b>ALTERNATE POWER SUPPLY ARRANGEMENT OF VIKARMPUR GUEST HOUSE</b> <b>TALCHER FERTILISER LIMITED, TALCHER</b>	PC183-TS-8001	0
		DOCUMENT NO.	REV.
	SHEET 23 OF 43		

**SPECIFICATION SHEET  
LT POWER & CONTROL CABLES**

PROJECT: Coal Based Fertilizer Plant		PLANT: Alternate Power to Vikrampur Guest House H		
ISSUED FOR : PROPOSAL <input type="checkbox"/>		ENQUIRY <input checked="" type="checkbox"/>	ORDER <input type="checkbox"/> FINAL <input type="checkbox"/>	
<b>GENERAL</b>		<b>AMBIENT CONDITION</b>		
Encl. Docs. :		Temp. Max./Min./Design Ref.: 46 / 1 / 50°C		
Vendor :		Relative Humidity: 100 %	Alt. above Sea Level < 1000M	
Vendor Ref. No. :		<b>Atmospheric Pollution</b> Dusts : Coal Dust & Urea Dust		
		Vapour : Ammonia & Highly Corrosive		
<b>TESTS TO BE WITNESSED:</b> Routine <input checked="" type="checkbox"/> Type <input type="checkbox"/> Acceptance <input checked="" type="checkbox"/> Others <input type="checkbox"/>				
<b>Type Tests Certificate of Similar Cable :</b> Required <input checked="" type="checkbox"/> Not required <input type="checkbox"/>				
<b>BASIC DATA</b>				
Item No.				
Ref. Stds.	IS:7098 (PART-1)	IS:7098 (PART-1)		
Voltage Grade	1.1 KV POWER CABLE	1.1 KV CONTROL CABLE		
System Earthing	NEUTRAL SOLIDLY EARTHED	NEUTRAL SOLIDLY EARTHED		
Type of Cable	POWER	CONTROL		
<b>CONDUCTOR</b>	ALUMINIUM/ COPPER	ALUMINIUM / COPPER	COPPER	
	STRANDED	STRANDED	STRANDED	
Insulation Type	XLPE EXTRUDED	XLPE EXTRUDED		
Inner Sheath Type	EXTRUDED PVC (ST2)	EXTRUDED PVC (ST2)		
<b>CONDUCTOR SCREEN</b>	Required	--	--	
	Not Required	--	--	
Material of Conductor Screen	--	--		
<b>ARMOURING</b>	Required	YES	YES	
	Material	GALVANISED STEEL STRIP	GALVANISED STEEL WIRE	
	No. of Layer	SINGLE	SINGLE	
Outer Sheath Type	EXTRUDED FRLS PVC TYPE-ST2	EXTRUDED FRLS PVC TYPE-ST2		
Special Requirements	--	--		
Drum Material	WOOD	WOOD		
<b>BILL OF QUANTITY</b>				
Item No.	No. of Core & Cross-Sectional Area in Sq. mm.	Qty. in M.	Preferred Drum Length	Remarks
<b>1.1 KV XLPE insulated, armoured, FRLS PVC outer sheathed, Power Cables of following sizes:-</b>				
1.	3.5CX300 sq. mm (Al)	Refer SOR	LATER	
<b>1.1 KV XLPE insulated, armoured, FRLS PVC outer sheathed, Control Cables of following sizes:-</b>				
1.	12CX2.5 sq. mm (Cu)	Refer SOR	LATER	
2.	3CX2.5 sq. mm (Cu)			

	<b>TECHNICAL SPECIFICATION FOR ELECTRICAL WORKS (SUPPLY &amp; ERECTION) ALTERNATE POWER SUPPLY ARRANGEMENT OF VIKRAMPUR GUEST HOUSE TALCHER FERTILISER LIMITED, TALCHER</b>	PC183-TS-8001	0
		DOCUMENT NO.	REV.
	SHEET 24 OF 43		

### TECHNICAL PARTICULARS CABLES

P PROJECT: Coal Based Fertilizer Plant		PLANT: Alternate Power to Vikrampur Guest House	
ISSUED FOR : PROPOSAL <input type="checkbox"/>		ENQUIRY <input checked="" type="checkbox"/>	ORDER <input type="checkbox"/>
		FINAL <input type="checkbox"/>	
<b>GENERAL</b>			
Make			
Ref. Standard			
Item No.			
Voltage Grade			
Suitable For Earthed / Unearthed System			
No. of Cores & Size of Conductor			
<b>CONSTRUCTIONAL DETAILS</b>			
<b>CONDUCTOR</b>	Material		
	Construction		
	No. & Dia of wires per Core		
<b>CONDUCTOR SCREEN</b>	Material		
	Thickness		
<b>INSULATION</b>	Material		
	Thickness		
	Core Identification Method		
<b>INSULATION SCREEN</b>	Material		
	Thickness		
<b>INNER SHEATH</b>	Type & Material		
	Thickness		
<b>ARMOURING</b>	Type & Material		
	Dia of Wire / Strip Thickness		
<b>OUTER SHEATH</b>	Material		
	Thickness		
<b>ELECTRICAL DATA</b>			
<b>CONTINUOUS CURRENT RATING WHEN LAID IN</b>	Ground At 30 <sup>0</sup> C		
	Air At 40 <sup>0</sup> C		
Short Circuit Current For 1 sec.			
<b>CONDUCTOR TEMP.</b>	Continuous		
	Short Time		
Resistance At Operating Temp. (Ohm / KM)			
Reactance At 50 C/S (Ohm/KM)			
Capacitance (F/Km)			
Insulation Resistance			
Polarisation Index			
<b>DERATING FACTOR CHART ATTACHED FOR</b>	Temperature		
	Grouping		
	Exposure to Sun		
<b>MECHANICAL DATA</b>			
<b>DIAMETER WITH TOLERANCE</b>	Over Inner Sheath		
	Over Armour		
	Overall		
Weight Of Cables Per KM			
Minimum Bending Radius			
Maximum Pulling Tension			
Standard Drum Length			
Tolerance On Drum Length			

Notes: Completely filled in Technical Particulars Sheet shall be furnished separately for each type & size of cable and shall be submitted after award of order for owner/consultant approval before commencement of manufacturing in line with NIT/PO.

	<b>TECHNICAL SPECIFICATION FOR ELECTRICAL WORKS (SUPPLY &amp; ERECTION) ALTERNATE POWER SUPPLY ARRANGEMENT OF VIKARMPUR GUEST HOUSE TALCHER FERTILISER LIMITED, TALCHER</b>	PC183-TS-8001	0
		DOCUMENT NO.	REV.
		SHEET 25 OF 43	

**SPECIFICATION SHEET  
LIGHTING FIXTURES AND ACCESSORIES**

PROJECT: Coal Based Fertilizer Plant		PLANT: Alternate Power to Vikrampur Guest House		
<b>ISSUED FOR :</b> PROPOSAL <input type="checkbox"/>		ENQUIRY <input checked="" type="checkbox"/>	ORDER <input type="checkbox"/> FINAL <input type="checkbox"/>	
<b>GENERAL</b>		<b>AMBIENT CONDITION</b>		
Ref. Stds. : IS / IEC		Temp.- Max / Min / Design ref.: 46 / 1 / 50°C		
Encl. Docs. :		Max Relative Humidity: ≤ 100% Alt. above sea : <1000 M		
Vendor :		Atmospheric	Dusts : Coal Dust & Urea Dust	
Vendor Ref. No. :		Pollution	Vapour : Ammonia & Highly Corrosive	
<b>SYSTEM DETAILS</b>		Area	Safe : <input checked="" type="checkbox"/> Hazardous : <input type="checkbox"/>	
Nominal Voltage : 240V ± 10%		Haz. Area class	Zone Encl. Gr. :	
Rated Frequency: 50Hz ± 5%		Temp. Class :		
Combined V & F variation : ± 10%		Location: Indoor <input checked="" type="checkbox"/>	Outdoor <input checked="" type="checkbox"/>	
<b>TESTS TO BE WITNESSED :</b> Routine <input checked="" type="checkbox"/> Acceptance <input type="checkbox"/> Type <input type="checkbox"/> Others <input type="checkbox"/>				
<b>BASIC DATA</b>				
Item no.				
Degree of Protection		IP-55		
Addl. Degree of Protection		--		
Material of Housing		Cast Aluminium alloy		
CONTROL	Separate	Yes		
GEAR	Integral	--		
Cable Type & Size		3 x 2.5 mm <sup>2</sup> (Cu)		
Looping facility		Yes		
CABLE	Required	Yes		
GLANDS	Type	Rolled Al		
MOUNTING	Required	Yes		
BRACKET	Not Required	--		
PAINTING	Type	Epoxy		
	Shade	631 as per IS: 5		
LOCATION	Indoor	--		
	Outdoor	Yes		
SAMPLE	Required	--		
	Not Required	Not Required		
Period for which Spares Required		2 years		
<b>BILL OF QUANTITY</b>				
Item No.	Lamp Type & Wattage	Description of Fixtures	Qty.	Remarks
1.	45W LED Lamp	Street Lighting Fixture	As per SOR	
2.				

	<b>TECHNICAL SPECIFICATION FOR ELECTRICAL WORKS (SUPPLY &amp; ERECTION) ALTERNATE POWER SUPPLY ARRANGEMENT OF VIKARMPUR GUEST HOUSE TALCHER FERTILISER LIMITED, TALCHER</b>	PC183-TS-8001	0
		DOCUMENT NO.	REV.
	SHEET 26 OF 43		

**TECHNICAL PARTICULARS  
LIGHTING FIXTURES AND ACCESSORIES**

PROJECT: Coal Based Fertilizer Plant		PLANT: Alternate Power to Vikrampur Guest House	
ISSUED FOR : PROPOSAL <input type="checkbox"/>		ENQUIRY <input checked="" type="checkbox"/>	ORDER <input type="checkbox"/>
		FINAL <input type="checkbox"/>	
<b>FIXTURE</b>			
Item No			
Make			
Type			
Ref. Standard			
<b>Suitable For</b>	Type Of Lamp		
	Wattage Of Lamp		
Suitable For Outdoor Use			
Control Gear Integral / Separate			
<b>Degree of Protection</b>	Fixture		
	Control Gear Box		
<b>Additional Degree of Protection</b>	Fixture		
	Control Gear Box		
<b>Material &amp; Finish</b>	Housing		
	Reflector		
	Control Gear Box		
	Diffuser / Louvre		
	Gasket		
<b>Pre - treatment</b>	Ext. Hardwares <8mm/>8mm		
	Housing		
	Reflector		
	Control Gear Box		
<b>Thickness of material</b>	Housing		
	Reflector		
	Control Gear Box		
Minimum Mounting Height			
Spacing / Height Ratio			
Light Output Ratio - Up / Down			
Surface Temp. Rise Range ( For FLP Fxt )			
<b>Cable Gland</b>	Type		
	Material		
	Qty. Fittings / Control Gear Box		
<b>Threaded Plug Provided</b>	Fixture		
	Control Gear Box		
<b>Looping Facility Available</b>	Fixture		
	Control Gear Box		
Mounting Bracket Provided			
Weight Of Fixture			
<b>Catalogue attached indicating</b>	General Arrangement		
	Light Distribution		
	Utilisation Factors		
	I FL / I Starting		
<b>ACCESSORIES</b>			
<b>Ballast</b>	Make & Maker's Type		
	Ref. Standard		
	Rating		
	Winding Wire Material		
	Insulation Class		
<b>Capacitor</b>	Power Loss in Ballast		
	Make & Maker's Type		
	Ref. Standard		
<b>Lamp Holder</b>	Rating		
	Make & Maker's Type		
	Ref. Standard		
<b>Starters</b>	Rating		
	Make & Maker's Type		
	Ref. Standard		

NOTE: Completely filled in Technical Particulars Sheet for each type of Lighting Fixtures shall be furnished after award of order for owner/consultant approval before commencement of manufacturing in line with NIT/PO.



	<b>TECHNICAL SPECIFICATION FOR ELECTRICAL WORKS (SUPPLY &amp; ERECTION) ALTERNATE POWER SUPPLY ARRANGEMENT OF VIKARMPUR GUEST HOUSE TALCHER FERTILISER LIMITED, TALCHER</b>	PC183-TS-8001	0
		DOCUMENT NO.	REV.
		SHEET 27 OF 43	

## SECTION – 3.0

### ERECTION, TESTING & COMMISSIONING SPECIFICATION

	<b>TECHNICAL SPECIFICATION FOR ELECTRICAL WORKS (SUPPLY &amp; ERECTION)</b> <b>ALTERNATE POWER SUPPLY ARRANGEMENT OF VIKARMPUR GUEST HOUSE</b> <b>TALCHER FERTILISER LIMITED, TALCHER</b>	PC183-TS-8001	0
		DOCUMENT NO.	REV.
		SHEET 28 OF 43	

## 1. SCOPE OF WORK

- 1.1 The scope of work shall include storage, handling, transportation, unpacking, checking, reporting of damages / defects, assembling, erection, installation, including fabrication, alignment, levelling, grouting, welding, bolting, painting (wherever specified), etc., testing and commissioning of various electrical equipment supplied by the contractor, earthing system, fabrication & installation of steel structural etc. as per drawings & documents, specifications, standards & codes, prevalent rules & regulations and best engineering practices.
- 1.2 The scope shall also include obtaining approval from statutory authorities, as required.

## 2. SCOPE OF ERECTION

- 2.1 The scope comprises of erection / installation, testing and commissioning of electrical equipment / items as indicated in SOR.
- 2.2 Laying of cables in excavated / RCC trenches and on cable trays as required.
- 2.3 Supply of single/double compression aluminium cable glands and crimping type tinned copper cable lugs, shall be provided by the electrical contractor. Normally, equipment shall be received at site with cable lugs and glands. Where these are short supplied or wrongly supplied by the equipment supplier, these shall be provided by the electrical contractor for which unit rates shall be quoted.
- 2.4 Excavation and back filling of cable trenches/direct buried cables.
- 2.5 Termination of power, control and lighting cables.
- 2.6 Fabrication with supply of MS material, consumable and hardware of frames, supports etc. as required.
- 2.7 Supply, laying & connection of the complete earthing system including supply of GI earth electrode as per sketch given, GI earthing strips, flexible earthing conductors etc.
- 2.8 Civil works such as digging of earth and refilling for directly buried cables, earth strips, cable protection pipes, earth electrode pits, ground mounted lighting pole foundations, civil works such as making earth pit inspection chambers with covers, grouting of base plate, channels, supports and foundation bolts, including chipping of concrete or in brick work for earth strips, pipes and other minor chipping for foundation preparation, if required, cutting holes in walls for racks, risers, light fitting brackets, sealing of cable entries and making good the same after installation of the equipment and levelling and other minor similar jobs shall be in contractor's scope.
- 2.9 Straight - through jointing of cables (wherever required)
- 2.10 All hardware required for successful commissioning, whether specifically mentioned or not in the specification.
- 2.11 Concrete foundations for pedestals, lighting poles, grouting of equipments etc., including supply of grouting materials.
- 2.12 Removal of materials / scraps to the scrap yard and stores etc. as per instructions of Owner / Consultant.
- 2.13 Supply and installation of any other item not specifically mentioned but found necessary by the engineer-in-charge for satisfactory completion of job.
- 2.14 All letter writing on switchboards, transformer, danger boards, sign etc shall be done by the contractor.
- 2.15 Any work not included in this tender but may be required, as decided by engineer-in-chief, such as site modification of panel wiring, mounting of additional equipment etc. for which extra payment shall be made as per the man-day-rates to be quoted for various categories of workmen.

	<b>TECHNICAL SPECIFICATION FOR ELECTRICAL WORKS (SUPPLY &amp; ERECTION) ALTERNATE POWER SUPPLY ARRANGEMENT OF VIKARMPUR GUEST HOUSE TALCHER FERTILISER LIMITED, TALCHER</b>	PC183-TS-8001	0
		DOCUMENT NO.	REV.
		SHEET 29 OF 43	

- 2.16 "AS BUILT" drawings with all site modifications shall be prepared by making the changes on owner's drawings.
- 2.17 All major civil engineering works pertaining to electrical equipment enclosed elsewhere in the tender.

### 3. CODES AND STANDARDS

- 3.1 The design, manufacture, testing, installation of the equipment shall comply with the latest issue of all relevant Indian Standards and codes of practices and all applicable Statutory Acts & Regulations.
- 3.2 The contractor shall have valid "A" class licence. The contractor must have PF & ESI codes covering all persons hired by him for carrying out the job. He shall engage suitably skilled / licensed workmen of various categories for execution of work supervised by supervisors / engineer of appropriate qualification and experience to ensure suitable quality of work.
- 3.3 The contractor shall observe safety rules and take all necessary safety precautions to carry out the internal electrification work.

### 4. GENERAL PROCEDURE FOR ERECTION

- 4.1 The general procedure governing "Transfer of equipment and materials to Contractor", erection and final acceptance of owner / consultant are given below:

#### 4.1.1 Storage of equipment at site

- a. All equipment and materials shall be properly stored by the contractor at site in the designated storage area provided by the owner. Contractor shall arrange to draw the necessary equipment / materials in the sequence required for erection and transport the same from contractor's store to erection point.
- b. The contractor shall keep proper record of the materials supplied by him / owner.
- c. The contractor shall ensure that all the materials drawn / supplied by him are stored indoor / under shade. However, if a package is temporarily stocked outdoor due to unavoidable reasons, this shall be ensured that the storage area is dry, hard and well-drained.
- d. Goods must not be placed directly on the floor / ground but shall be kept on blocks, 60 mm to 120 mm above the floor level such that the bottom is well ventilated.
- e. In case of outdoor storage, the contractor at his own cost shall provide waterproof PVC sheets/ tarpaulin to cover all goods so as to protect them from rain etc. These sheets / tarpaulin shall be removed for inspection once in a week and if found moist or mouldy, shall be dried in direct sunlight.
- f. In addition to the above, the equipment manufacturer's storage instructions, if any, shall be strictly followed.

#### 4.1.2 Contractor's inspection at site

- a. On receipt of any material (supplied by the contractor) at site, contractor shall fully unpack and inspect all equipment received for completeness, signs of damages, defect etc. in the presence for owner's representative. Any damage / short supply detected shall be recorded immediately. The contractor shall be required to make good / replace / repair the defective / damaged items at no extra cost to the owner.

#### 4.1.3 Handling and cleaning

- a. The contractor shall be responsible for proper handling and cleaning of all materials / equipment drawn / supplied by him until owner / consultant finally accepts the erected equipment.

	<b>TECHNICAL SPECIFICATION FOR ELECTRICAL WORKS (SUPPLY &amp; ERECTION) ALTERNATE POWER SUPPLY ARRANGEMENT OF VIKARMPUR GUEST HOUSE TALCHER FERTILISER LIMITED, TALCHER</b>	PC183-TS-8001	0
		DOCUMENT NO.	REV.
		SHEET 30 OF 43	

- b. Equipment shall be handled with care by experienced riggers under guidance of competent supervisors and as per rigging marks given on cases. Dragging on floor shall be avoided and crane / suitable rollers shall be used for moving the equipment at any times.
- c. The contractor shall be fully responsible for the safe keeping of equipment issued to him till these are erected, tested, commissioned by him and accepted by owner / consultant.

#### 4.1.4 Transportation

This involves transportation of various electrical equipments / materials from contractor's store to erection site. When transporting the equipment, it shall be loaded on suitable trailer / trucks as per capacity and size of equipment, and shall be properly supported on the trailers / trucks by means of ropes / stoppers to avoid damage or tilting due to heavy jerks and vibration. Precautions, if any, displayed on equipment shall be strictly observed.

#### 4.1.5 Erection Requirements

- a. All work shall be carried out as per drawings supplied. Placing on foundation, aligning, grouting, connecting, fixing danger notice plate / board on equipment as specified, meggering, labelling and painting shall form part of erection requirements.
- b. Fixing of supporting frames / pedestals, grouting, cutting and dressing holes in walls / ceiling and any other minor civil work necessary for installation and levelling of electrical equipment are included in electrical erection scope.
- c. The scope of erection also includes cable dressing / clamping / minor rerouting, minor relocation of fittings, internal cleaning of equipment, overhauling and minor repairs.
- d. Fabrication of clamps from the materials specified and clamping of cables on racks, trays etc. fixing of single core cables in tri-foil formation in aluminium clamps, earthing of cable armour and lead sheath, wherever necessary (and as per the details given by Consultant) fall under erection scope of work.
- e. Marking of cables by fixing / grouting the cable marks / number tags at every 25 metres along entire route of cables are included in the scope of work. The tags shall be made of Aluminium Strips.
- f. The contractor shall without any extra cost, touch up with paint all electrical equipment which are damaged / scratched during handling, erection or repair. The paint used shall match exactly the painted surface of the equipment on which touch-up is done, and shall be epoxy based.
- g. The descriptions given above are only to give a preliminary idea about the scope of work and they do not limit the entire scope to these descriptions only. Hence all other parts of the tender document shall be read in conjunction with the referred standards, associated drawings, specification sheets and schedule of materials & services to assess actual scope of work.
- h. The contractor shall undertake erection of all equipment specified herein in accordance with good engineering practices in conformity with statutory regulations and Code of Practice and to the entire satisfaction of the purchaser / owner.
- i. The contractor shall arrange all the necessary erection tools, tackles, testing and measuring instruments and shall supply all erection materials as required.

#### 4.1.6 Erection Supervision by OEM Suppliers

- a. For guiding / supervising erection of sophisticated equipment, services of main equipment supplier's engineer may be made available free of cost by the contractor for the electrical equipment. However, this will neither absolve the contractor from his responsibility nor his obligation to provide his own supervisors or technical personnel.

- Transformer

	<b>TECHNICAL SPECIFICATION FOR ELECTRICAL WORKS (SUPPLY &amp; ERECTION) ALTERNATE POWER SUPPLY ARRANGEMENT OF VIKARMPUR GUEST HOUSE TALCHER FERTILISER LIMITED, TALCHER</b>	PC183-TS-8001	0
		DOCUMENT NO.	REV.
		SHEET 31 OF 43	

- b. The contractor shall have to comply with all the directions of Engineer-in-Charge, drawings etc. issued to him within the scope of his contract by supplier's engineer.

## 5. SPECIFICATION FOR ELECTRICAL ERECTION

### 5.1 General

- 5.1.1 These specifications lay down the erection procedures to be followed for each type of equipment, over and above the general "Erection Requirements".
- 5.1.2 The contractor shall also follow manufacturer's instructions and any other instructions of consultant / Principal / Statutory bodies during erection.
- 5.1.3 Suggestive Erection Drawings shall be supplied to the successful bidder for Lighting, Earthing, Cable Tray Routing, etc. These drawings may be suitably modified, if required, to suit site requirement with the approval of owner / consultant.
- 5.1.4 As-Built Drawings shall be prepared by the bidder and supplied to owner/ consultant.

### 5.2 Transformer

#### 5.2.1 Handling

- a. Transformers shall be lifted by lugs or shackles provided for the purpose to avoid unbalance while lifting.
- b. It shall be ensured that Lifting chains / slings do not interfere with any part of the transformer.
- c. Cover bolts shall be checked for tightness. If found loose, it shall be tightened fully before handling. Care shall be taken that the bolt does not rotate to avoid damage of the gasket.
- d. Jacks shall be used, if required, only on jacking pads provided for the purpose (jacks shall never be used under valves or radiators tubes).
- e. Transformer shall never be left without putting stoppers of the wheels.

#### 5.2.2 Erection

- a. Foundation of the transformer shall be prepared and checked for its level as per Drg. before shifting / transferring the transformers from the stores.
- b. Proper time shall be given for curing the level of rails.
- c. Wheels shall be fixed before placing of the transformer in position. Wheels of the transformers shall be checked for its proper movement. Greasing shall also be done on the shaft of wheel before placing the wheels in position. Split pins must be used / placed in position before its rolling.
- d. Transformer shall be placed on the prepared foundation only.
- e. Transformer's wheels shall be checked for its free movement on the rails/ plates. It shall be then levelled & aligned with the bus ducts, which shall be connected on the LT side of the transformer.
- f. Stoppers to the transformer wheels shall be provided immediately after alignment to prevent any movement.
- g. Cleaning of all the accessories like radiators, cooling fans, valves, air cell type conservator tank, explosion vent pipe, bushings and other accessories shall be done.
- h. Radiators shall be flushed with hot oil before assembly.
- i. Cloth only shall be used for cleaning purposes.

	<b>TECHNICAL SPECIFICATION FOR ELECTRICAL WORKS (SUPPLY &amp; ERECTION) ALTERNATE POWER SUPPLY ARRANGEMENT OF VIKARMPUR GUEST HOUSE TALCHER FERTILISER LIMITED, TALCHER</b>	PC183-TS-8001	0
		DOCUMENT NO.	REV.
		SHEET 32 OF 43	

**CAUTION:** While working on the transformers with hand-holes or bushing holes, take care that no tools or any other foreign matters are dropped into the tanks. All the loose tools shall be properly tied and secured.

- j. All accessories such as radiators, conservator, valves, explosion vent pipe, Buchholz relay, HV and LV bushings, cable end termination boxes, marshalling box, instruments, capillary tubes, silica gel breather with dried silica gel, fans etc. shall be assembled as per vendor's drawings and instructions.
- k. Operation of shut off valves and tightness of all gasket joints shall be checked before topping up of oil. Thermometers shall also be fixed.
- l. Oil samples from each drum for dielectric strength shall be tested. Oil with standing 40 KV for 1 minute shall only be filled.
- m. Oil shall be filtered with filtering machine by using metallic hose.
- n. Bottom drain valve shall be used to fill oil in the transformer tank to prevent aeration in oil.
- o. It shall be ensured during oil filling operation that no air pockets are left in the tank and no dust or moisture enters the oil. All air vents shall be opened. Oil flow rate shall be reduced when oil level is almost upto the bottom of the main cover to prevent internal pressure from rupturing the diaphragm of pressure relief pipe. Sufficient time shall be allowed to escape all air bubbles. Air bubble accumulated in Buchholz relay shall be released by opening air release cock provided on the top. Vent plugs shall be closed.
- p. Cables shall be connected to HV and LV terminals of transformer.
- q. Control cables / power cables shall be connected to Marshalling Box. Stop push button mounted on the wall of transformer room shall be connected to trip the transformer.
- r. Transformer body shall be earthed at two separate points to main earthing strip.
- s. Transformer neutral shall be earthed to a separate and distinct neutral earth pit (through NER, wherever applicable) as per design and drawings.
- t. Danger notice board conforming to IS: 2551 and IE Rules 1956 shall be provided on enclosure or door of the enclosure.
- u. Transformer Room's door / enclosures shall be earthed as per IE Rules, 1956.
- v. Safety items i.e. fire extinguishers, shock treatment chart, fire buckets with screened sand etc. shall be provided.

### 5.3 **Cable Installation**

#### 5.3.1 **General**

- a. All fabrication, cutting, laying, spacing, fixing etc. of cables, trays, supports, hangers etc. shall be as per drawings and instructions of Owner / Engineer-in-Charge.
- b. The contractor shall keep accurate record of cable drums, the drum nos. and actual length of cable taken out of each drum. Each cable length shall be cut from a specific drum as per approved schedule of cable. Lengths of cable runs shown in the cable schedule are calculated lengths only, hence the actual lengths shall be measured at site before laying and cutting the cable. The contractor shall take extreme care to adjust cable runs from drums so that joints in the cable are avoided and wastage reduced to minimum.
- c. For purpose of measurement of cable run for payment the length of cable between and terminations only shall be considered.

	<b>TECHNICAL SPECIFICATION FOR ELECTRICAL WORKS (SUPPLY &amp; ERECTION) ALTERNATE POWER SUPPLY ARRANGEMENT OF VIKARMPUR GUEST HOUSE TALCHER FERTILISER LIMITED, TALCHER</b>	PC183-TS-8001	0
		DOCUMENT NO.	REV.
		SHEET 33 OF 43	

### 5.3.2 Laying

- a. The cable drums should be properly mounted on jack / cable wheel. Make sure that the spindle is suitable for carrying weight of the drum without bending. Check that spindle is laying horizontal on the bearing so as to prevent the drum creeping to one side or to the other while rotating.
- b. Unroll the cables from the drum in correct direction. Rotate drum only as per arrow mark given in the cable drum. Ensure that the end protection box attached to the flange of the drum is removed and securing rope cut to allow cable and move freely. Rotate the cable drum and simultaneously pull cable steadily and with even pulls and not with unnecessary jerk or strain. In no case the cable shall be allowed to twist or kink since this is likely to spring the armour and fracture the insulation and outer serving of the cable.
- c. Do not drag the cable on floor or hard surface. Use only wooden / steel cable rollers for this purpose.
- d. Cable should not be bent sharply to a small radius. The cable bending radius shall be as large as possible and will not be less than 15 times the outside diameter for XLPE cables and 12 times for PVC cables. At joint termination the individual core of cable shall not be bent with bending radius of less than 15 times the diameter over the insulation.
- e. Where cables are laid on the MS racks, trays etc. ensure that trays / racks / supports are fixed properly in an approved manner or according to the drawings. Check from drawings that for horizontal runs of cable, bracket, risers, supports, angles are grouted or fixed in formation as required.
- f. In sub-station where large no. of cables rise to panels/ switchboards, it shall be ensured that these risers do not interfere with cables on racks and rising cables do not interfere with cables on racks and rising cables do not cross the other cables in horizontal runs. Risers are to be properly supported so that weight of cable does not fall on terminations. All cable crossings shall be avoided.
- g. Cable laid in trenches should be sealed at the entry to hazardous area / non-hazardous area as per direction of owner / engineer-in-charge.
- h. Openings in substation basement and floors for entry of cables shall be sealed after the cables are laid.
- i. Cables shall be clamped by taking care to be taken to space clamps at such intervals as to prevent buckling of cables.
- j. The laying of the cable on the racks shall be done in an approved manner and according to the drawings supplied.
- k. Where cables are laid in cable slits, the slits after laying of cables shall be filled with sand & lean cement mixture and plastered so that surface flushes with top of slit.

### 5.3.3 Directly Buried Cables

- a. Laying of under ground directly buried cables shall include excavation of earth along the cable route, laying of Hume / GI pipes for road crossing, back filling, ramming, removing of extra earth including supply of bricks, sand etc. as per drawing and instruction of Owner / Engineer-in-Charge.
- b. Broken bricks shall not be use for brick working. Only Class-I bricks shall be used.
- c. If new cables are laid to cross existing cables, the new cable shall be laid under existing cables at depth of not less than 300 mm from the existing cable. It shall be ensured that the approach of new cable to the crossing is uniform and gradually sloped.



	<b>TECHNICAL SPECIFICATION FOR ELECTRICAL WORKS (SUPPLY &amp; ERECTION) ALTERNATE POWER SUPPLY ARRANGEMENT OF VIKARMPUR GUEST HOUSE TALCHER FERTILISER LIMITED, TALCHER</b>	PC183-TS-8001	0
		DOCUMENT NO.	REV.
		SHEET 34 OF 43	

- d. Where cables are directly laid into ground, trenches should be dug up to such a depth as to ensure that the depth of the top of the entire cable below the ground level is min. 750 mm for medium and low voltage cables, and min.1050 mm for high voltage cables. Before laying of cables at these trenches, bottom of the trench should be properly levelled up and all odd and sharp materials removed. Trench bottom then should be bedded with a 75 mm thick layer of sand. Approval of Owner / Engineer-in-Charge shall be taken for preparation of this bed before laying of cables. Cables shall be laid in the trenches in straight runs. Care shall be taken so that any kinds or bends are not formed. After laying of the cables, bricks shall be placed length wise on both the sides of the cables along the entire length to form trough.
- e. Fill up space between bricks with sand up to height of the bricks. Then place bricks closely width wise on top of the sand layer throughout the length. Fill up loose earth in trench, ram properly to compact, remove extra earth from site. Broken bricks shall not be use for brick working. Only Class-I bricks shall be used.
- f. If new cables are laid to cross existing cables, the new cable shall be laid under existing cables at depth of not less than 200 mm from the existing cable. It shall be ensured that the approach of new cable to the crossing is uniform and gradually sloped.
- g. Fix cable markers at interval not exceeding 30 Mtrs. In straight portion, at bends in cable route apart and at joints on the entire cable route length of the cables. The cable markers shall be made of pre-cast concrete blocks of 300 mm x 350 mm x 350 mm size with markings of “HT CABLE”, “LT CABLE”, “Depth of Cable”, “Arrow Marks” etc. inscribed. These shall be supplied by the contractor at no extra cost and fixed as per directions of the Owner / Engineer-in-Charge. The top of the above concrete slabs shall have a smooth finish with cement only.
- h. Laying of cables under road crossings etc. shall be done in pipes, and pipe ends shall be sealed with bitumen compound and sand as required after cables are laid. Backfilled soil shall be rammed thoroughly to prevent road surface cracking due to settlement of loose soil.
- 5.3.4 Laying in Readymade Trenches**
- a. RCC slabs / chequered plates lifted from trenches for laying cables shall be put back in position at close of work every day to avoid accident & damage to cables in the trench.
- b. When cables pass through pipes, pipe ends shall be sealed with bitumen compound and sand as required.
- c. Protection pipes shall be provided, whenever cables enter from the floor, trench etc. in the equipment and sealing in and around these pipes shall be done.
- 5.4 Cable Jointing and Termination**
- 5.4.1 General**
- The scope of work shall include but not limited to the followings:
- a. Soldering / crimping of sockets / ferrules and connections at all joints/ terminations as per specifications. Sockets shall be provided at all terminations except where pressure clamp type terminals are provided.
- b. Glanding of cable and fixing of cable boxes.
- 5.4.2 Specifications**
- a. HT XLPE cables shall be terminated by use of heat shrink type termination kits.
- b. All LT XLPE power and control cables shall be terminated through compression type gland.
- c. In case of LT XLPE cables, armours shall be suitably earthed in compression type glands. For HT XLPE cables, this shall be done either in glands or by any other suitable means like bonding the armour with suitable wire and connecting same to the earth terminals inside cable box.

	<b>TECHNICAL SPECIFICATION FOR ELECTRICAL WORKS (SUPPLY &amp; ERECTION) ALTERNATE POWER SUPPLY ARRANGEMENT OF VIKARMPUR GUEST HOUSE TALCHER FERTILISER LIMITED, TALCHER</b>	PC183-TS-8001	0
		DOCUMENT NO.	REV.
		SHEET 35 OF 43	

- d. All lighting and control cables shall be provided with crimped Al / Cu Sockets before termination in junction boxes.

#### 5.4.3 Crimping

- a. For all power cables, crimping type Al lugs for Al cables and tinned Cu lugs for Cu cables shall be provided. These lugs shall be crimped on the cable conductors by means of special hand/ hydraulic crimping tools. Before crimping the socket inhibiting grease shall be smeared over the conductor. Conductor shall be shaped properly before sliding the socket over it. Crimping shall be done in an approved manner.
- b. All the control cables, which shall be of copper conductor, shall be terminated without any additional lugs in screwed type terminals provided in various equipments.
- c. Bimetallic washer shall be used at copper to aluminium connection.

#### 5.4.4 Jointing

- a. The jointing shall be done in an approved manner. Care shall be taken not to damage the insulation when opening the cable for jointing.
- b. Before commencing soldering of the socket, conductor shall be thoroughly cleaned and insulation protected. The ferrules shall be thoroughly cleaned. Ferrule and each strand of the cable shall be thoroughly sweated with solder to tin them and fill the conductor gaps to remove all air pockets. Soldering materials of approved quality as per ISS practice shall be used. Taping of the conductors shall be done in an approved manner after crimping / soldering.
- c. Filling up compound and sealing the cable box shall never be done in one operation. After the first pouring of compound, it should be topped up again with compound and then sealed.

#### 5.4.5 Straight Through Joints

- a. Jointing of XLPE & XLPE cables shall be done with extreme care and manufacturer's instructions shall be strictly followed. Soldering of sockets shall also be done with extreme care as indicated above.

Earth continuity wire shall be plumbed and / or clamped. Compound shall be filled according to the instructions of manufacturers of terminating kit / cable. Joints made inside trench or on rack shall be properly supported. Wherever joints are made inside ground, brick masonry work shall be done around the joint box and filled with sand, and there after covered with earth at no extra cost.

- b. A tent shall be used in all circumstances where jointing work is being done outdoor, for protection against rain and to prevent dust from being blown in to exposed joints and jointing materials. Extreme care shall be taken to maintain proper phase sequence while terminating at equipment ends. Records of connection details shall be maintained. Conductors shall be shaped properly while terminating and no sharp bends shall be given. Where numbers of cables are to be connected in parallel, proper tests shall be done before connection, so that no cross connection shall be made. No phase crossings shall be allowed for making the connections.
- c. Cables shall be supported adequately at the entry to cable box / equipment so that load of cable does not come on cable glands.
- d. All cables shall be meggered (checked for insulation resistance) before and after jointing and insulation values recorded.
- e. While terminating at equipment end, each core shall be properly tagged with numbering ferrules as per nomenclature given in the drawings. Wires should be dressed and clamped neatly, bolting shall be done properly.

	<b>TECHNICAL SPECIFICATION FOR ELECTRICAL WORKS (SUPPLY &amp; ERECTION) ALTERNATE POWER SUPPLY ARRANGEMENT OF VIKARMPUR GUEST HOUSE TALCHER FERTILISER LIMITED, TALCHER</b>	PC183-TS-8001	0
		DOCUMENT NO.	REV.
		SHEET 36 OF 43	

## 5.5 Earthing & Lightning

### 5.5.1 General

- a. Painting of all earth strip joints with anti-corrosive paints shall be carried out as per details given in drawings and instruction of Owner / Engineer-in-Charge.
- b. All electrical equipment rated 415 V and above shall be connected to earth bus by two separate and distinct earth connections. All equipment rated 240 V and below shall be earthed with single earth conductor.

### 5.5.2 Specifications

- a. Types and sizes of earthing conductors shall be as indicated in the SOR attached. All earthing installations shall conform to IS-3043 / National building code 2016 / IS / IEC : 62305
- b. Underground conductors shall run at a depth of 600 mm below ground level. Where these conductors run along with cables, they shall be laid at the same depth as cables. Where conductors run on wall, ceilings, they shall be laid on clamps or brackets made out of Al/GI strips.
- c. Wherever, earthing conductor is passing through floor, walls etc. the conductor shall be taken through PVC / GI pipes.
- d. All paints, enamel etc. shall be removed from point of contact before making connections.
- e. Connections between G.I. strips shall be done by welding. For connecting Al conductor / G.I. wire, Al socket shall be crimped on the conductor / wire. At the equipment end, connections shall be done by bolting.
- f. Connection between Al & GI shall be done by bolting. Graphite grease shall be applied on contact surfaces.
- g. Epoxy resin paint or bitumen shall be applied on welded or bolted joints to prevent corrosion and taping done as indicated in the drawing. Connections between Al wires shall be done by crimping back to back Al ferrule.
- h. Earth electrodes - Earth electrodes shall be provided as per drawings / specification. Work includes excavation of earth, installation of electrodes and test links etc., supply and filling of charcoal and common salt, back filling of earth and removal of extra earth as specified earlier. It also includes making brick wall around the electrode and cover as per drawings / specifications. The testing links shall be grouted on brick wall and connections with earth electrode and conductors shall be made. Distance between two electrodes shall not be less than 10 meters and may be located 4 M away from building foundation.
- i. Earth pits for equipment earthing, neutral earthing and lightning protection shall be separate. However, these pits shall be inter-connected.

## 5.6 **ERECTION OF STRUCTURES**

### 5.6.1 Specification

The fabrication work shall be done as per drawings / specifications / sketches in an approved manner and to the entire satisfaction of owner / engineer-in-charge. The contractor shall take adequate measures to avoid wastage. Scrap quantity shall not exceed 2% of total quantity used for erection.

### 5.6.2 Erection of racks, risers, supports etc.

- a. Erection of racks and risers for cable supports shall be done along the cable routes as indicated in the drawings. The contractor before erection shall check the route for any obstruction like process pipe lines, structures, equipment etc. In case of obstructions, the

	<b>TECHNICAL SPECIFICATION FOR ELECTRICAL WORKS (SUPPLY &amp; ERECTION) ALTERNATE POWER SUPPLY ARRANGEMENT OF VIKARMPUR GUEST HOUSE TALCHER FERTILISER LIMITED, TALCHER</b>	PC183-TS-8001	0
		DOCUMENT NO.	REV.
		SHEET 37 OF 43	

matter shall be brought to the notice of owner / engineer-in-charge in writing and racks shall be re-routed as per his instructions.

- b. As and where indicated in the drawings, supports for racks, risers etc. shall be welded on the steel structure, such as MS beams, pipe trestles, insert plates provided in the RCC column etc. for erection of racks.
- c. Wherever indicated, supports for racks, risers, shall be grouted on walls. The racks, risers etc. shall be installed on such supports and those properly welded.
- d. Opening on walls / floors shall be provided where racks / risers are crossing floors/ walls.
- e. Heavy channels, risers may also be grouted on the floors in addition to supports provided from walls, ceilings, steel structures etc.
- f. As indicated in the drawings, racks and risers shall be erected either in single tier/ multi tier formation.

#### 5.6.3 Erection of supports in trench

- a. Supports and Hangers shall be grouted with rag bolts on the walls of readymade concrete trench.
- b. In existing trench wall, contractor may be required to provide pockets for grouting cable supports at some points. This shall be done without any extra cost to the owner.
- c. In case of requirement of insert plates for support of cable rack, the contractor shall weld such plates to the reinforcement MS rods. This shall be done by chipping the concrete for exposing the reinforcement MS rods and thereafter welding the plates and making good the concrete chipping by plastering.

5.6.4 The pipes will have to be bent (wherever required) and fixed / embedded in floor, wall and ground for laying the cables. Neoprene bushes shall have to be fixed at the end of such pipes.

5.6.5 GI trays of different sizes shall be cut in size and fixed on racks and risers. Fixing of trays shall only be done after erection / welding / painting of the supports as required.

5.6.6 Erection of support frames for miscellaneous equipments, base channels for transformers and switchboards etc. shall be carried out at no extra cost.

5.6.7 Dismantling of steel fabrication and re-erecting as required by owner / engineer-in-charge shall have to be carried out by the contractor.

5.6.8 Dismantling of cable racks and re-erecting as required by owner / engineer in charge shall be carried out by the contractor.

### **6. GENERAL PROCEDURE FOR TESTING & COMMISSIONING**

6.1 Before proceeding with the work, contractor shall fully inspect all installed Electrical Equipment for completeness, signs of damages, defects etc. and record all discrepancies noticed. The contractor shall be required to make good / repair / replace the damaged components at no extra cost.

#### 6.2 Testing and Commissioning Requirements

- a. All works shall be carried out in accordance with the drawings, supplier's instructions / manuals for equipment and as per relevant ISS & Code of Practices.
- b. Before conducting test on any equipment, the contractor shall obtain permission from owner / engineer-in-charge and all tests shall be conducted in their presence.
- c. Results of each test shall be recorded by the contractor immediately after the test on approved performa and counter signed by the owner's authorised representative. The test results shall be furnished in four copies in the form of 'Test Certificates'.

	<b>TECHNICAL SPECIFICATION FOR ELECTRICAL WORKS (SUPPLY &amp; ERECTION) ALTERNATE POWER SUPPLY ARRANGEMENT OF VIKARMPUR GUEST HOUSE TALCHER FERTILISER LIMITED, TALCHER</b>	PC183-TS-8001	0
		DOCUMENT NO.	REV.
		SHEET 38 OF 43	

- d. Copies of the record shall be handed over to owner / engineer-in-charge.
- e. The Contractor shall commission all electrical equipment and carry out all pre-commissioning / commissioning tests inclusive of no-load and on-load tests on motors, and shall be responsible for final adjustments of relays, motors, instruments, starters, breakers etc. as per operational data supplied and as per directions of Engineer-in-Charge.
- f. All terminals, cable joints, earth terminals which are opened for testing purposes shall be re-terminated and re-insulated by the Contractor to restore their original state.

g. Painting

The contractor shall without any extra cost, touch up with paint all electrical equipment which are damaged / scratched during testing and commissioning work. The paint used shall match exactly painted surface of the equipment on which touch up is done.

6.3 Cleaning and Regular Maintenance.

Till the commissioned equipment is finally accepted by owner / engineer-in-charge, Contractor shall be responsible for regular cleaning and maintenance of all electrical equipment. The maintenance job is to be done in consultation with or on advice from the Owner/ Consultant.

**7. TESTING & COMMISSIONING SPECIFICATIONS**

7.1 These specifications lay down the testing and commissioning procedures to be followed for each type of equipment, over and above the general requirements laid down in specifications for erection.

Manufacturer's instructions and any other instructions of owner / engineer-in-charge / statutory bodies shall also be followed by the contractor during testing and commissioning.

The contractor shall maintain and furnish the records of all equipments i.e. Transformer, etc. including any special test as per manufacturer's manual.

7.2 Transformer

7.2.1 Final testing before commissioning shall be done in cold condition after drying out the transformer and disconnecting H.V. and L.V. side cables by removing link in disconnecting chamber, cables and also earth connections to neutral.

7.2.2 At least 1000 Volt megger shall be used for 33 KV winding and manufacturer's test certificates shall be compared for the purpose. 500 Volt megger shall be used for auxiliary power cables and control cable and values shall be preferably more than 2 MΩ.

Polarization Index shall be recorded as below to determine whether drying is necessary or not:-

$$PI = \frac{IR\ 10\ Min}{IR\ 1\ Min}$$

Evaluation of insulation condition based	Base on PI	Drying on PI
-----	-----	
Hazardous	< 1	Mandatory
Bad	1-1.5	Mandatory
Doubtful	1.5 - 2	Recommended
Adequate	2 - 3	No
Good	3 - 4	No
Excellent	> 4	No

	<b>TECHNICAL SPECIFICATION FOR ELECTRICAL WORKS (SUPPLY &amp; ERECTION) ALTERNATE POWER SUPPLY ARRANGEMENT OF VIKARMPUR GUEST HOUSE TALCHER FERTILISER LIMITED, TALCHER</b>	PC183-TS-8001	0
		DOCUMENT NO.	REV.
		SHEET 39 OF 43	

### 7.2.3 Oil Tests

- a. Crackle Test: Cleaned Iron piece shall be heated red hot and put in the oil taken in a pot. In case of crackle sound, presence of moisture is indicated.
- b. Dielectric Strength Test: It shall be done as prescribed in Appendix 'C' of IS: 335. The oil should withstand minimum of 40 KV for 1 minute.

Even oil conditions are found satisfactory in testing after final topping. It is advisable that as an additional precaution, the transformers shall be dried out.

### 7.2.4 Drying out Procedure

- a. Drying out of the transformers shall be carried out in accordance with IS: 10028.

Before drying out following points shall be checked:-

- Any oil leakage through bushings and radiators
- Transformer tank is connected to the earth
- Temperature indicators are suitably calibrated and connected

- b. Precautions when drying :-

Maximum sustained temperature shall not be more than 80°C. Do not leave the transformer unattended during drying out period. Watch the transformer during drying out process and record carefully all observations viz. Oil temperature, winding temperature and insulation resistance of H.V. and L.V. windings. Drying out shall be continued till the insulation resistance value is steady prescribed in Standard Code of practice and IS: 10028 Part-II and steady value remains constant for 12 hours. Within the above period, several samples of oil are to be tested to ascertain dielectric strength. All readings shall be recorded (hourly/ half hourly) for insulation resistance and temperature of oil and winding. Sample of transformer oil shall be collected from bottom only. The oil shall be allowed to settle for at least 24 hrs.

In case the insulation value does not improve by the above method, low voltage equal to impedance voltage shall be supplied to HV side for few hours after short-circuiting the LV side. During the process, regular readings of insulation resistance of winding to earth, winding to winding and temperature against time shall be recorded.

If necessary / depending upon the manufacturer's recommendations, a vacuum pressure of 635 mm of mercury shall be applied for removal of air bubble. Hot air shall be released after drying out is done. Vent cocks and screws after release of air shall be closed.

### 7.2.5 Ratio Test :

3 phase, 415 volt shall be supplied on HV side for every tap position and reading shall be taken on other side. For every tap changing, supply shall be switched off for off-load changer.

### 7.2.6 Polarity Test

3 phase, 415 volts shall be applied to HV side. One terminal of HV side shall be joined to corresponding terminal of LV side, say A-a. The voltage across A-a, A-b, B-a, B-b, B-c, C-a, C-b, C-c, N-a, N-b, N-c shall be recorded and vector group shall be ascertained.

### 7.2.7 Phasing for Paralleling Operations

Two transformers shall be connected on primary side. Terminal 'a' of secondary side shall be connected to bus-bar which corresponds to the equivalent terminal of second transformer. Both transformers shall be at same tap. Then 415 volt, 3 phase supply shall be connected to primary side. Circuit breaker of second transformer shall be closed. The corresponding secondary terminal voltage of two transformers, a1-a2, b1-b2, c1-c2 shall



	<b>TECHNICAL SPECIFICATION FOR ELECTRICAL WORKS (SUPPLY &amp; ERECTION) ALTERNATE POWER SUPPLY ARRANGEMENT OF VIKARMPUR GUEST HOUSE TALCHER FERTILISER LIMITED, TALCHER</b>	PC183-TS-8001	0
		DOCUMENT NO.	REV.
		SHEET 40 OF 43	

be measured. These voltages shall be zero in case both transformers are of same polarity and phase displacement. Voltmeter of the double reading of voltage of the secondary shall be used for measuring their condition. In case of star connected secondary winding having star joint earthed, secondary terminals need not be connected as stated earlier.

#### 7.2.8 Buchholz Relay Testing

Air pressure shall be inserted through petcock gently till alarm contacts make. Pressure shall further be increased till trip contact makes. For low oil pressure also check shall be done.

#### 7.2.9 Temperature Indicators

Temperature indicator shall be calibrated for the alarm contact properly.

#### 7.2.10 Following points shall be checked before commissioning the transformer :-

##### a. General Inspections

- i) Assembly of accessories and mounting shall be checked with reference to Drgs.
- ii) Tightness of all cover bolts, flange etc. shall be checked.
- iii) Oil leakage through bushings, valve, radiator valve etc. shall be checked.

##### b. Oil Level

- i) Correct level in conservator shall be checked.
- ii) Oil level in disconnecting chamber and in thermometer pocket shall be checked.

##### c. Buchholz Relay

It shall be checked that floats are at normal position and shut off valve between relay & conservator is open.

##### d. Breather

- i) It shall be checked that the protective cover on air passage is removed.
- ii) Oil level in seal chamber and condition of silica gel shall be checked.

##### e. Explosion Vent

- i) It shall be checked that the diaphragm is intact and no oil visible in gauge glass.
- ii) Equaliser pipe valve between vent and conservator shall be opened.

##### f. Radiator

All the valves between radiator bands and main tank shall be opened.

##### g. Thermometer

The connection of C.T. and Heater element for winding temperature indicator shall be checked.

##### h. Wiring

Wiring from instruments to marshalling box and to switch board/ control panel shall be checked.

##### i. HV and LV Bushing and connections.

- i) Bushings shall be cleaned and connections shall be checked for outgoing and incoming lines.
- ii) Gap of arcing horn (HV bushing) shall be checked.



	<b>TECHNICAL SPECIFICATION FOR ELECTRICAL WORKS (SUPPLY &amp; ERECTION) ALTERNATE POWER SUPPLY ARRANGEMENT OF VIKARMPUR GUEST HOUSE TALCHER FERTILISER LIMITED, TALCHER</b>	PC183-TS-8001	0
		DOCUMENT NO.	REV.
		SHEET 41 OF 43	

iii) High pot test and cable and test of transformer shall be completed.

- j. After all checking found O.K., the breaker for incoming of transformer shall be made ON for charging the transformer. It shall be watched for at 24 hrs. without load. Then it can be loaded after finding everything O.K.

### 7.3 **Cables**

- a. All HT & LT cables shall be tested for insulation resistance with 1000V megger after termination.

For 11 KV---With 5000V Megger (Motorised)

For 1.1 KV-- With 1000V Megger

IR shall be measured between phases and between phase & earth. The voltage shall be applied for 1 minute.

- b. All HT cables shall be tested for high voltage as per IS: 1255 after making all termination and joints followed by IR test.

### 7.4 **Lighting**

Before energising any lighting circuit, the IR values (phase to phase and phase to earth) shall be recorded for entire wiring installation. The testing shall be done with 500 V megger. After switching on the power supply, load of each circuit shall be measured.

### 7.5 **Earthing**

- Measurement of earth resistance of each earth pit
- Checking earth grids for size, continuity and connections
- Checking size and continuity of earth connections from grid to each equipment
- Measurement of connections to earth at equipment which are likely to have highest earth resistance
- Measurement of earth loop impedance for checking the operation of protective devices in case of earth fault.
- The continuity of earthing and resistance of each earth pit and grid shall be measured with earth megger.

### 7.6 **Miscellaneous Equipment**

Under this are included, exhaust fans, blowers, limit switches, vibrators, electro-magnets, air pressurisation unit etc. The following tests shall be conducted.

- a. Measurement of insulation resistance
- b. Check up the direction of rotation.
- c. Operational test

## 8. **DOCUMENTATION**

8.1 For the purpose of completion certificate, the following documents will be deemed to form completion document:

- a. The technical documents according to which the work was carried out.
- b. Final check-list and completion report.

8.2 Three sets of construction drawings showing therein the modifications and correction made during the course of execution signed by Owner / Engineer-in-charge.

8.3 Test certificates for the materials purchased by Contractor.

	<b>TECHNICAL SPECIFICATION FOR ELECTRICAL WORKS (SUPPLY &amp; ERECTION) ALTERNATE POWER SUPPLY ARRANGEMENT OF VIKARMPUR GUEST HOUSE TALCHER FERTILISER LIMITED, TALCHER</b>	PC183-TS-8001	0
		DOCUMENT NO.	REV.
		SHEET 42 OF 43	

- 8.4 Material appropriation statement for the materials issued by Owner for the works and list of surplus materials returned to Owner's stores duly supported by necessary documents.
- 8.5 No claim certificate by the Contractor certifying that the entire work done by him under the contract has been measured & accepted for the final bill to his satisfaction and that he will have no claim(s) concerning any work(s) or part thereof performed by him under the Contract, to Owner except otherwise indicated in the final bill.
- 8.6 The completion certification shall be issued by Owner within 30 days of the Contractor furnishing documents listed in this clause jointly certified by Owner / Engineer-in-charge and Contractor's Site Engineer.
- 9. HANDING OVER TO OWNER**
- 9.1 The contractor shall hand over the complete installation as a whole. Minor works not specified or mentioned in the scope or SOR but required to complete the job as a whole will have to be done by the contractor without extra cost. Any equipment / installation shall not be deemed as handed over to Owner until the same is complete in all respect and is accepted in writing by the Owner / Engineer-in-charge.
- 9.2 The final acceptance of the work shall be after the demonstration of guarantees by the Contractor. Owner shall issue the final acceptance / taking over certificate upon fulfilment of the guarantees.
- 10. OBLIGATIONS & RESPONSIBILITIES OF CONTRACTOR**
- The contractor's obligations and responsibilities shall include but not limited to the following:
- 10.1 To deploy skilled, semi skilled and unskilled personnel in requisite numbers and as per scheduled programme so as to complete the WORK as per overall project schedule.
- 10.2 To deploy suitably qualified supervisors and engineers in requisite numbers to assure execution of good quality job as per best engineering practices and to the full satisfaction of Owner / Consultants.
- 10.3 Safety supervisor shall be deployed at site that monitors safety aspect during the site construction work. Contractor to note that all workers shall use PPE (helmet, safety shoes, hand gloves, goggles, double lanyard safety belt etc. and they shall be medically tested before putting into the job.
- 10.4 To prepare detailed planning and execution schedule considering the availability of fronts and materials. This shall be reviewed by Owner / Engineer-in-charge and Contractor shall be required to keep updating the same (as per the instructions of Owner / Engineer-in-charge) to take care of any changes in the availability of fronts and materials and to complete all jobs as per the overall project schedule. Owner / Engineer-in-charge shall in no way be held responsible for such changes.
- 10.5 To check for quantity compliance between bill of materials and drawings for cable, structural, earthing materials etc. and intimate Owner / Engineer-in-charge sufficiently in advance regarding discrepancies, if any.
- 10.6 To arrange all required tools and tackles, consumables, instruments, erection materials & machineries etc. for handling erection, testing & commissioning of complete electrical installation.
- 10.7 To arrange and supply storage tanks for drinking water so as to avoid any inconvenience that may be caused due to interruption in water supply at times.
- 10.8 To provide proper storage and security arrangements for his tools, tackles, equipments, materials etc. as well as equipment and materials issued by Owner / Engineer-in-charge to Contractor. Owner / Engineer-in-charge shall not be responsible for any loss or damage to items in the custody of Contractor at site for any reason whatsoever.

	<b>TECHNICAL SPECIFICATION FOR ELECTRICAL WORKS (SUPPLY &amp; ERECTION)</b> <b>ALTERNATE POWER SUPPLY ARRANGEMENT OF VIKARMPUR GUEST HOUSE</b> <b>TALCHER FERTILISER LIMITED, TALCHER</b>	PC183-TS-8001	0
		DOCUMENT NO.	REV.
		SHEET 43 OF 43	

- 10.9 Completion of all repairs arising out of defective work done by Contractor, Owner / Engineer-in-charge may at his discretion require the Contractor to rectify certain defects in materials caused due to bad workmanship of supplier and / or during transportation. For such work of course, the payment modalities shall be settled by mutual agreement before starting such rectification jobs.
- 10.10 To maintain all the records for men, materials and execution of job as required by law as well as Owner / Engineer-in-charge.
- 10.11 To get his work inspected by Owner / Engineer-in-charge and get approved from statutory agencies such as but not limited to Electrical Inspector, Factory Inspector etc.
- 10.12 All co-ordination with Statutory Authorities shall be contractor's responsibility. Only statutory fee required for approval shall be paid by the owner.
- 10.13 To make arrangements for services such as transport, medical, lighting, canteen etc. for working round the clock.
- 10.14 In addition to safety regulations indicated in this enquiry, Owner / Engineer-in-charge may issue certain safety directives, which shall have to be followed meticulously without any reservation.
- 10.15 To undertake and execute work and supply as per scope of work, scope of supply and follow Technical Conditions including specification for electrical erection, specification for electrical testing and commissioning and as per schedule of rates
- 10.16 Reconciliation of all materials issued by owner / supplied by contractor.
- 10.17 Handing over of the completed works to owner / engineer-in-charge as per procedure laid down by Consultant.
- 10.18 To submit documentation forming part of request for issue of completion certificate.
- 10.19 Clearing the site after cleaning the areas where the Contractor executed the job, stored the materials and built his office, fabrication shop etc.



# ENGINEERING STANDARD

## POWER TRANSFORMERS

REV	REV DATE	EFF DATE	PURPOSE	PREPD	REVWD	APPD
2	20.01.07	01.02.07	ISSUED FOR IMPLEMENTATION	<i>Sharma</i> AV	<i>SC</i> BKC / SC	<i>BB</i> BB
1	16.01.06	30.01.06	ISSUED FOR IMPLEMENTATION	AV	BKC	BB
0	OCT'97	--	ISSUED FOR IMPLEMENTATION	RNS/JKT/SC	JKT	HSW

**CONTENTS**

SECTION NUMBER	DESCRIPTION	SHEET NUMBER
1.0	SCOPE	3
2.0	STANDARDS TO BE FOLLOWED	3
3.0	SERVICE CONDITIONS	3
4.0	OPERATING REQUIREMENTS	3
5.0	GENERAL DESIGN FEATURES	4
6.0	CONSTRUCTIONAL FEATURES	5
7.0	FITTINGS	7
8.0	PAINTING	9
9.0	TESTS AND INSPECTION	9
10.0	DRAWINGS AND DOCUMENTS	10
11.0	SPARES	10
12.0	PACKING	10
13.0	DEVIATIONS	11
ANNEXURE - I	LIST OF FITTINGS	12
ANNEXURE - II	LIST OF SPARES	13
ANNEXURE - III	DOCUMENTATION FOR POWER TRANSFORMERS	14

**1.0 SCOPE**

- 1.1 This standard covers the technical requirements of design, manufacture, testing at works and despatch in well-packed condition of Power Transformers.
- 1.2 This standard shall be applicable for 3 phase, core type, separate winding power transformers of rating 315 KVA and above.
- 1.3 This standard shall be read in conjunction with the relevant specification sheets.

**2.0 STANDARDS TO BE FOLLOWED**

- 2.1 The design, manufacture and testing of the equipment covered by this standard shall comply with the latest issue of IS: 2026, unless otherwise specified. Equipment complying with equivalent IEC standards shall also be acceptable.
- 2.2 The design and operational features of the equipment offered shall comply with the provisions of the latest issue of the Indian Electricity Rules and other relevant Statutory Acts and Regulations. The supplier shall, wherever necessary, make suitable modifications in the equipment to comply with the above.
- 2.3 Wherever any requirement, laid down in this standard, differs from that in Indian Standard Specifications, the requirement specified herein shall prevail.

**3.0 SERVICE CONDITIONS****3.1 Ambient Conditions**

These shall be as indicated in Specification Sheet.

**3.2 System Details**

These shall be as indicated in Specification Sheet.

**4.0 OPERATING REQUIREMENTS**

- 4.1 The transformer shall be suitable for operating at the rated capacity continuously at any of the taps, under the ambient conditions and with the voltage and frequency variations indicated in Specification Sheet without exceeding the permissible temperature rise and without any detrimental effect on any part.
- 4.2 The transformer shall also be capable of delivering rated current at a voltage equal to 105 % of the rated voltage.
- 4.3 The transformer shall be capable of allowing at least three consecutive starts of the largest Squirrel Cage Induction Motor, as indicated in Specification Sheet, while delivering 85% of its rated power without any harmful effect on its insulation. It shall be possible to repeat the starting cycle once in eight hours.
- 4.4 The transformer shall be designed to be loaded as per IS: 6600.



4.5 The transformer shall be so designed as to operate in parallel satisfactorily with similar transformers.

## 5.0 GENERAL DESIGN FEATURES

5.1 The design of the transformers shall be in accordance with the latest practice.

### 5.2 Rated Voltage, Frequency and Phase Connection

These shall be as indicated in Specification Sheet.

### 5.3 Tap Changing Gear

5.3.1 Each transformer shall be provided with on-load/ off-circuit tap changing equipment on the high voltage winding with taps, as specified in Specification Sheet. It shall be mounted on one side, in an easily accessible position.

5.3.2 The range of tap changer shall be as indicated in Specification Sheet and arranged in steps of 2.5% unless specified otherwise in Specification Sheet.

5.3.3 The off-circuit tap changing shall be affected by an externally operated handle capable of being padlocked in any position and provided with tap position indicator and mechanical stops at the extreme positions.

5.3.4 For transformer specified with on-load tap changer, tap changing gear shall be complete with tap position indicator, limit switch, lock and key and necessary control panel. Provision shall be made for auto-manual operation. The manual operation shall be possible both from the panel as well as from field. In case the tap changer is located in a separate housing, the housing shall be connected with the conservator for oil connection. A separate buchholz relay shall be provided in such a case. Emergency mechanical manual device shall also be provided. A minimum of 2 lakh trouble-free operations shall be guaranteed.

### 5.4 Impedance Voltage

The impedance voltage of the transformer at 75°C shall be as indicated in Specification Sheet. This shall be guaranteed within limits specified in Specification Sheet at principal tap position.

### 5.5 Losses

The losses under the full load condition, at the rated voltage and frequency shall be indicated by the vendor at 75°C. These shall be guaranteed within the tolerable limits specified in IS: 2026 at principal tap position. The purchaser has the right to impose penalty charges or reject the transformer in case of any difference in the test and guaranteed values.

### 5.6 Temperature Rise

The temperature rise of the winding, oil and core shall not exceed the values specified in IS: 2026 when the transformer is delivering its rated output continuously under the service conditions as indicated in Specification Sheet.



**5.7 Insulation Level**

All windings up to maximum system voltage of 72 KV shall have uniform insulation to earth. For windings having higher maximum system voltage, graded insulation is acceptable.

**5.8 Terminal Arrangements**

The HV and LV side terminal arrangement shall be provided as specified in Specification Sheet. Disconnecting link chambers shall be provided on the transformer primary side in all cases as well as on secondary side, except where the termination is through bus duct. The disconnecting chambers shall be oil filled, preferably connected with the main tank through an isolating valve and also provided with a drain valve. However for system not exceeding 11 KV, air filled disconnecting chamber may be accepted. Suitable cable end box complete with cable glands and lugs shall be provided for termination of cables as indicated in Specification Sheet. Gland plate for single core cables shall be non-magnetic.

5.9 The transformer shall be able to withstand the electro-dynamic and thermal stresses due to terminal short circuit of the secondary, assuming the primary side fed from an infinite bus. All leads and windings in cores shall be properly supported, clamped and tightened after vacuum drying to ensure the short circuit withstand capacity. The short circuit withstand duration shall be 3 Secs.

5.10 The short circuit test results for similar transformers shall be furnished.

5.11 The transformer shall be so designed as to minimise any undue noise and vibration.

5.12 Due attention shall be given in the design for the suppression of harmonics.

**5.13 Cooling System**

5.13.1 The cooling system shall be as indicated in Specification Sheet. In case the transformer is designed for two types of cooling, the output rating for each type shall be indicated in the offer. The minimum acceptable output shall be 70% of rated output when forced type of cooling system is not in operation.

5.13.2 Wherever ONAF Cooling is specified, the cooling fans shall be adequately rated and shall be suitable for auto/manual and local/remote operation. Auto operation shall be through winding temperature indicator contact. Cooling fan motors may be group controlled and shall be suitable for DOL starting. Individual DOL circuit shall be provided with bi-metallic thermal overload relay, back up fuse, contactor etc.

**6.0 CONSTRUCTIONAL FEATURES****6.1 Core**

6.1.1 The transformer core shall be of high grade, non-ageing, electrical silicon cold rolled magnetic sheet steel of low hysteresis loss and high permeability. The



maximum flux density in any part of the core and yoke at rated voltage and frequency shall not exceed 1.7 Tesla. The core structure shall be securely grounded to prevent electrostatic potential. Lifting eyes and lugs shall be provided on the limbs and coils assembly. Preferably no bolt shall be used in the cores. Clamping shall be done external to the limb. Bolts passing through the yoke, if any, shall be insulated for 2 KV for transformers rated up to 33 KV and 5 KV for higher voltage ratings.

6.1.2 The temperature of the core shall not exceed that permitted in IS.

## 6.2 Tank

6.2.1 The tank shall preferably be made of mild steel plate of adequate thickness capable of withstanding stress not less than  $0.40 \text{ kg/cm}^2$ , properly welded and gusseted to ensure a rigid construction. It shall also be able to withstand normal transportation shocks without any deformation and shall be capable of withstanding following vacuum.

Highest System Voltage	MVA Rating	Vacuum in mm of Hg
Up to 72 KV	Up to 1.6	250
	Above 1.6 to 20	500
	Above 20	760
Above 72 KV	For all Ratings	760

6.2.2 For outdoor transformer, the top of the tank, the marshalling box and the headers of radiators, shall be of such a construction so as to prevent accumulation of water.

6.2.3 Guides shall be provided to facilitate tanking and unloading of the core with the coil assembly. The details of anchoring of core and coil assembly of the tank shall be furnished.

6.2.4 Radiators, where necessary, shall be provided on the tank to facilitate cooling. These shall be detachable type and shall be provided with isolating valves at ends, drain plug and air release plug. The radiators shall be fabricated out of minimum 1.25 mm thick seamless steel tubing or pressed sheet steel. For sizes up to 500 KVA, cooling tubes shall be acceptable.

6.2.5 Means for lifting and jacking of the transformer shall be provided.

## 6.3 Windings

6.3.1 Each coil shall be made out of paper insulated electrolytic grade copper conductor. Similar coils shall be interchangeable. Successive coils of a winding shall be connected by accessible joints and shall be brazed and finished smooth to prevent abrasive damage to insulation. There shall be no sharp bends in the connecting leads to prevent corona discharge. Aluminium foil wound transformer will also be acceptable.

6.3.2 The winding assembly shall be dried and impregnated in the vacuum with tested insulating oil. The insulation resistance and polarization index of the winding measured after impregnation shall be furnished in the test certificate.



6.3.3 For transformers rated 20 MVA and above vapour phase drying shall be adopted.

6.3.4 The magnitude of impulse surges transferred from HV to the LV winding by inductive and capacitive coupling shall be limited to a value below the rated impulse strength of the LV winding. The impulse voltage test results and surge distribution on windings for similar transformer shall be furnished.

#### 6.4 **Insulation Materials**

6.4.1 Class 'A' insulating materials specified in IS: 1271 shall be used. Paper insulation shall be new and free from punctures. Wood insulation, where used, shall be well seasoned and treated.

6.4.2 The mineral oil shall comply with IS: 335. 10% extra oil shall be supplied along with the transformer in non-returnable drums.

6.4.3 For the transformers required to be filled up with inert gas for transport purpose, the required amount of oil including 10% extra shall be supplied in non-returnable drums.

#### 6.5 **Bushing**

The bushing insulator shall be rated for the maximum system voltage and shall comply with the requirements laid down in IS. The minimum current rating shall be 400 Amps. in case of overhead line connected transformers, the bushings shall be outdoor type having required creepage distances to suit the atmospheric condition and complete with arcing horns. In case of transformers connected with bus duct or cable, the bushings shall be enclosed in the terminal box. In either case, they shall be detachable from outside of the tank. The hardware shall be of tinned copper or nickel plated brass suitable to receive the conductor sizes as specified. Separate neutral bushings shall be provided for earthing the neutral, if indicated in Specification Sheet. All bushings shall be marked with the symbols corresponding to the connection diagram indicated in the diagram plate and in accordance with IS.

### 7.0 **FITTINGS**

7.1 Fittings as listed in Annexure - I shall be provided. Any other fittings which may be necessary for the satisfactory operation of the transformer shall also be provided on each transformer.

7.2 All fittings shall conform to relevant Indian Standard Specifications.

7.3 Fittings such as conservator and associated pipes, explosion vent pipe etc. shall be designed to withstand vacuum as specified in Clause 6.2.1 against atmospheric pressure.

7.4 Fittings such as rating plate, dehydrating breather, off-circuit tapping switch, dial type thermometer etc. which need to be observed/ operated, shall be mounted at convenient heights of not more than 1.5 M from the base of the transformer and located so as to be clearly visible from the front.



- 7.5 All opening shall be provided with gasketted metallic covers for protection during transportation.
- 7.6 All valves shall be of globe/butterfly type provided with blanking plates. The valve body shall be made of either Carbon Steel with trim of 13 Cr. steel or gun metal.
- 7.7 The rating plate, the terminal diagram and terminal marking plates shall be made of Aluminium and shall contain relevant details as per IS: 2026. The Code No. of equipment shall be marked on a separate plate.
- 7.8 All terminals shall be anti loosening type and complete with connectors of required size. The earthing terminals shall have identification marks.
- 7.9 **Winding Temperature Indicator**
- Winding temperature indicator for measuring hot spot temperature of the winding shall comprise of current transformer image coil, temperature sensing element, capillary tube jacketed with PVC sleeve, 150 mm dia. local indicating instrument with two pairs of contacts one for alarm and other for trip and maximum point indicator capable of being reset by hand without tools.
- 7.10 **Oil Temperature Indicator**
- Oil temperature indicator for measuring top oil temperature shall comprise of 150 mm dial type thermometer, thermometer pocket and capillary tube jacketed with PVC sleeve. Thermometer shall have two pairs of contacts, one for alarm and other for trip and maximum point indicator capable of being reset by hand without tools.
- 7.11 **Buchholz Relay**
- The buchholz relay as per IS: 3637 shall be of double float type, provided with, two pairs of contacts, one for alarm and other for trip, facility for testing by injection of air by hand pump and with a cock for draining and venting of air. The relay shall be provided with shutoff valves on the conservator side as well as on the tank side.
- 7.12 The alarm and trip contacts of all protective devices shall be potential free and rated for 1 Amp at 110 V / 220 V D.C. as specified in Specification Sheet.
- 7.13 **Marshalling Box**
- 7.13.1 A marshalling box shall be provided to accommodate all auxiliary devices except those which are to be located directly on transformer or housed in a separate panel.
- 7.13.2 The marshalling box shall be dust, weather and vermin proof type made of sheet steel of not less than 2 mm thick. The box shall be rectangular in shape having sufficient space for easy termination of cables. The terminal block shall be pressure clamp type. 10% spare terminals shall be provided.



7.13.3 Suitable heavy duty double compression type rolled Aluminium cable glands for all incoming and outgoing cables shall be provided. The outgoing cables to Owner's panel shall be as indicated in Specification Sheet.

#### 7.14 **Current Transformers**

The current transformers, if specified in Specification Sheet, shall be provided and shall comply with IS: 2705. The C.T. terminals shall be accessible through a weatherproof removable cover for the purpose of testing etc. CT polarity shall be clearly marked. The C.T. for standby earth fault protection shall be 15 VA, 5P10. The C.T's for differential and restricted earth fault protection shall be of Class PS accuracy. The values of  $V_k$  and  $I_{mag}$  for these CTs shall be furnished at the order stage.

#### 7.15 **Wiring**

All controls, indication and protective devices provided on the transformer shall be wired upto the terminal block inside the marshalling box, by means of stranded copper heat resistant PVC insulated armoured cable of 1.1 KV grade and size not less than 2.5 sq. mm. Wiring shall be properly fixed on cable tray with at least 100 mm clearance from the transformer body. Suitable identification mark shall be provided on all wires.

7.16 All bought out items shall be of reputed make to be approved by Consultant/ Purchaser.

### **8.0 PAINTING**

8.1 The surface to be painted shall be shot or sand blasted to remove all dust, scale and foreign adhering matter. All traces of oil and greases should be removed by suitable treatment.

8.2 All steel surfaces in contact with insulating oil shall be painted with heat resistant oil insoluble insulating varnish.

8.3 All steel surfaces exposed to outside shall be painted with suitable anti-rust and anticorrosive paints. Epoxy paints shall be used, if indicated in Specification Sheet.

8.4 All paints shall be carefully selected to withstand tropical heat and extremes of weather. The paint shall not scale off, crinkle or be removed by abrasion due to normal handling.

8.5 Unless otherwise specified, the finishing shade shall be light grey Shade No. 631 as per IS: 5.

8.6 1 litre of paint per transformer shall be supplied for touch up at Site.

### **9.0 TESTS AND INSPECTION**

9.1 All transformers shall be routine tested as per IS: 2026. Transformer oil shall be tested as per IS: 335.



- 9.2 Additional tests, wherever specified, shall be carried out on one transformer of each rating.
- 9.3 All the above mentioned tests shall be carried out in the presence of Purchaser's representative. In addition, the transformers shall be subject to stage inspection at works and inspection at site for final acceptance.
- 9.4 These inspections shall, however, not absolve the Vendor from their responsibility for making good any defect which may be noticed subsequently.

**10.0 DRAWINGS AND DOCUMENTS**

- 10.1 The drawings and documents as per Annexure-III shall be furnished, unless otherwise specified.
- 10.2 All drawings and documents shall have the following descriptions written boldly:
- Name of Client
  - Name of Consultant
  - Enquiry / order number with plant / project name
  - Equipment Code No. and Description

**11.0 SPARES**

- 11.1 Spares for operation and maintenance
- Item wise unit prices of spare parts with recommended quantity shall be quoted along with the equipment as specified in Annexure-II.
- 11.2 Commissioning Spares
- Commissioning spares, as required, shall be supplied with the main equipment. Item wise list of recommended commissioning spares shall be furnished for approval.
- 11.3 Any other spare parts not specified, but required, shall also be quoted along with the offer.
- 11.4 All spare parts shall be identical to the parts used in the equipment.

**12.0 PACKING**

- 12.1 The transformer shall be suitably packed to avoid damage in transit and shall be properly sealed so as to completely exclude oxygen and moisture from coming in contact with oil. Bushing shall be wrapped in straw ropes or similar material and complete transformer shall be packed in wooden crates.
- 12.2 The packing box shall contain a copy of the installation, operation and maintenance manual.
- 12.3 All loose pieces shall be separately wrapped in moisture resistant paper and marked with identification mark of the corresponding transformer.

**ENGINEERING STANDARD****ES: 8043****2**

DOCUMENT NO.

REV.

**POWER TRANSFORMERS**

SHEET 11 OF 14

**13.0 DEVIATIONS**

- 13.1 Deviations, if any, from this standard shall be clearly indicated in the offer with reasoning.
- 13.2 Deviations, if any, from the data furnished in specification sheet shall be indicated therein beside the data by encircling it.



**ANNEXURE - I****LIST OF FITTINGS**

- I. The fittings as given below shall be provided for all the ratings of transformers.
1. Oil Sampling Valve.
  2. Filter valves with plug.
  3. Radiator shutoff valves on top and bottom for each unit.
  4. Buchholz relay shutoff valves.
  5. Winding temperature indicator for 1000 KVA and above.
  6. Oil temperature indicator.
  7. Oil level indicator with minimum marking.
  8. Oil conservator complete with drain plug and oil filling hole with cover.
  9. Buchholz relay with air release device and alarm and trip contacts.
  10. Silica gel breather with oil seal and connecting pipe.
  11. Explosion vent.
  12. Bi-directional rollers.
  13. Inspection holes with cover.
  14. Marshalling Box.
  15. Rating Plate.
  16. Diagram and Terminal marking plate.
  17. Lifting lugs.
  18. Jacking pad.
  19. Earthing Terminals.
  20. Air release device.
  21. Neutral bushing for earthing.
- II. The additional fittings as given below shall be provided, if specified in the specification sheet, indicating the Sl. Nos. only.
1. Magnetic oil level gauge with low oil level alarm contact.
  2. Hauling lugs for extra high voltage transformers.
  3. Protective CTs for
    - a) Stand-by earth fault.
    - b) Restricted earth fault.
    - c) Differential protection.
  4. Bi-directional wheels if already bi-directional rollers not considered.
  5. Skids.

**ANNEXURE - II****LIST OF SPARES**

The spare parts as given below shall be quoted for all the ratings of the transformers:

1. Bushings with accessories for all voltage grades.
2. Complete set of gaskets.
3. Explosion vent diaphragm.
4. Oil Level Gauge.
5. Complete charge of Silicagel.
6. Gland packing /O-rings for every valve.
7. Buchholz Relay.
8. Dial Type Thermometer.
9. One set of fixed and movable contacts for OLTC.
10. One set of fan and it's motor.
11. One set of pump and it's motor.
12. One set of switches, fuses and lamps etc. for Cooler Control Panel and OLTC panel.

**Note:**

1. Item 9 to 12 shall be quoted only where applicable.
2. All spare parts shall be identical to the parts used in the transformer.



## ANNEXURE - III

## DOCUMENTATION FOR POWER TRANSFORMERS

Sl. No.	Description	Documents Required (Y / N)		
		With Bid	For Approval	Final
1.	Specification Sheet, duly completed	N	Y	Y
2.	Technical Particulars, duly filled-in	N	Y	Y
3.	Dimensional drawing for complete Transformer, Marshalling Box, disconnecting chamber, terminal chambers etc.	N	Y	Y
4.	Schematic and Wiring Diagram	N	Y	Y
5.	Terminal arrangement drawing	N	Y	Y
6.	Installation, operation and maintenance manual	N	N	Y
7.	Catalogues and test certificates for bought out accessories	N N N	N	Y
8.	Type test certificates of similar transformer		N	Y
9.	Test Certificates	N	N	Y
10.	Guarantee Certificates	N	N	Y
11.	Spare parts list with identification marks	N	N	Y

**Note:**

- 1.
2. 4 hard copies & 1 soft copy shall be supplied for approval after order within 4 weeks from the date of LOI.
3. 8 hard copies & 2 soft copies in CD shall be submitted as final documents prior to despatch of the equipment. These shall be made in sets and supplied in fine plastic coated folder.

Y - Yes, N - No



## ENGINEERING STANDARD

### CABLES

REV	REV DATE	EFF DATE	PURPOSE	PREPD	REVWD	APPD
2	20.01.07	01.02.07	ISSUED FOR IMPLEMENTATION	<i>Shunup</i> AV	<i>Roh</i> BKC/SC	<i>BB</i> BB
1	16.01.06	30.01.06	ISSUED FOR IMPLEMENTATION	AV	BKC	BB
0	JAN'98	--	ISSUED FOR IMPLEMENTATION	RNS/ JKT/ SC	JKT	HSW
REV	REV DATE	EFF DATE	PURPOSE	PREPD	REVWD	APPD

**ENGINEERING STANDARD****ES: 8160****2**

DOCUMENT NO.

REV.

**CABLES**

SHEET 2 OF 8

**CONTENTS**

SECTION NUMBER	DESCRIPTION	SHEET NUMBER
1.0	SCOPE	3
2.0	STANDARDS TO BE FOLLOWED	3
3.0	SERVICE CONDITIONS	4
4.0	OPERATING REQUIREMENTS	4
5.0	GENERAL DESIGN AND CONSTRUCTIONAL FEATURES	4
6.0	SPECIAL PURPOSE CABLES	5
7.0	CABLE DRUM	6
8.0	TESTS AND INSPECTION	6
9.0	DRAWINGS AND DOCUMENTS	6
10.0	DEVIATIONS	7
ANNEXURE - I	DOCUMENTATION FOR CABLES	8

**CABLES****1.0 SCOPE**

- 1.1 This standard covers the technical requirements of design, manufacture, testing at works and dispatch in well packed condition of power and control cables.
- 1.2 The standard shall be read in conjunction with relevant specification sheets and other relevant references as specified therein.

**2.0 STANDARDS TO BE FOLLOWED**

- 2.1 The design, manufacture and testing of cables covered by this standard shall comply with the latest issue of following Indian Standards, unless otherwise specified. Equipment complying with equivalent IEC standards shall also be acceptable.

IS: 1554 Part (I) -- PVC insulated (heavy duty) electric cables for working voltages upto and including 1100 volts.

IS: 1554 Part (II) -- PVC insulated (heavy duty) electric cables for working voltages from 3.3 KV upto and including 11 KV.

IS: 7098 Part (I) -- Cross linked polyethylene insulated PVC sheathed cables for working voltages upto and including 1100 volts.

IS: 7098 Part (II) -- Cross linked polyethylene insulated PVC sheathed cables for working voltages from 3.3 KV upto and including 33 KV

IS: 7098 Part (III) -- Cross linked polyethylene insulated thermoplastic sheathed cables for working voltages from 66 KV upto and including 220 KV

IS: 692 -- Paper insulated lead sheathed cables for rated voltages upto and including 33KV

IS: 694 -- PVC insulated cables for working voltages upto and including 1100 volts

IS: 5831 -- PVC insulation and sheath of electric cables

- 2.2 The design and operational features of the cables offered shall also comply with the provisions of latest issue of the Indian Electricity Rules and other relevant Statutory Rules & Regulations. The supplier shall, whenever necessary, make suitable modification in the cables to comply with the above mentioned rules.

- 2.3 Wherever any requirement, laid down in this standard, differs from that in Indian Standard Specifications, the requirement specified herein shall prevail.

**3.0 SERVICE CONDITIONS****3.1 Ambient Conditions**

These shall be as indicated in specification sheet.

**3.2 System Details**

These shall be as indicated in specification sheet.

**4.0 OPERATING REQUIREMENTS**

The cables shall be suitable for operating continuously at the rated capacity as specified in relevant I.S. under the ambient conditions in specification sheet without exceeding the permissible temperature rise and without any detrimental effect on any part.

**5.0 GENERAL DESIGN AND CONSTRUCTIONAL FEATURES**

5.1 The design, manufacture and workmanship of cables shall be in accordance with the latest practice.

5.2 All materials to be used shall be new, unused and of the best quality.

**5.3 Conductors**

The power cables shall be of stranded Aluminium / copper round or shaped conductors and control cables shall be of annealed high conductivity stranded copper round conductors. The conductors shall comply with the requirements of IS: 8130.

**5.4 Insulation**

The conductor insulation shall be type A/C as indicated in specification sheet and shall comply with relevant IS.

**5.5 Fillers**

The cables shall have suitable fillers wherever required, laid up with conductors to provide substantially circular cross section before the inner sheath is applied.

**5.6 Inner Sheath**

Inner sheath, wherever applicable shall be ST1/ ST2 type compound applied by extrusion process except for paper cables for which it shall be of lead or lead alloy.

**5.7 Armouring**

All power and control cables shall be armoured as specified in specification sheet. The single core cables shall be armoured with hard drawn Aluminium





taps/ wires or any other suitable nonmagnetic material. All other cables shall have galvanized steel wire / strip armouring.

### 5.8 Outer Sheath

The outer sheath shall be ST1/ ST2 type compound applied by extrusion process and suitable to withstand atmospheric pollution, resistance to termites, fire retardant and coloured black.

### 5.9 Screening

Screening over conductor and insulation shall be provided as per relevant standard unless specified otherwise. The screening for control cables if specified shall be of aluminium, mylor or equivalent and provided with tinned drain wire which shall be continuous and permanently connected to the screen.

### 5.10 Identification

The individual cores of cables shall be coloured as per relevant IS. Where it is not possible to distinguish the cores by colour, coloured strip shall be applied on the cores or core nos. shall be marked on each core at regular intervals. All cables shall carry the manufacturer's name or trade mark, the cable size, voltage rating and year of manufacture at intervals not exceeding 100 meters. Running meter markings shall also be provided throughout the length of the cable.

### 5.11 Dimension

The overall dia. and dia. under armour of the cables shall be indicated by the vendor in the technical particulars. These shall be guaranteed with a tolerance of  $\pm 5\%$  but not exceeding 2 mm.

5.12 The cut ends of the cables shall be sealed by means of non-hygroscopic materials.

## 6.0 SPECIAL PURPOSE CABLES

### 6.1 Flame Retardant Low Smoke Cables

Flame retardant low smoke cables, where specified in specification sheet, shall have outer sheath of PVC having following values.

- |                                |   |       |
|--------------------------------|---|-------|
| - Minimum oxygen index         | - | 29%   |
| - Minimum temperature index    | - | 250°C |
| - Maximum acid gas generation  | - | 20%   |
| - Maximum smoke density rating | - | 60%   |

### 6.2 Heat Resistant Cables

Heat resistant cables, where specified in specification sheet, shall be of silicon rubber insulated laid circular with asbestos worming and overall glass fibre

**CABLES**

braided and varnished. Silicon rubber insulating compound shall conform to IS:6380 and the constructional features shall conform generally to IS:9968.

**7.0 CABLE DRUM**

- 7.1 The cables shall be supplied in non-returnable wooden drums (or steel drums if specified) of heavy construction. The wood used for construction of the drums shall be properly seasoned, sound and free from defects.
- 7.2 Cables shall be supplied in specified drum lengths. Where no such indication is given, standard drum lengths may be offered.
- 7.3 The tolerance on each drum of cable shall not exceed  $\pm 2.5\%$ . However, no negative tolerance on HV cables is acceptable.
- 7.4 All cable drums shall have stencilled data as per relevant IS as well as the purchaser's order no., item no. & drum no.

**8.0 TESTS AND INSPECTION**

- 8.1 The following tests shall be carried out on the cables as per relevant IS.
- i) Routine Tests - On all cables
  - ii) Acceptance tests - On representative length of each size
  - iii) Type tests - Wherever specified on one cable drum of each size
- 8.2 In addition, the following tests shall be carried out on all fire retardant low smoke cables as per IS or as per the following standards:
- i) Oxygen and temperature index test as per ASTM-D-2863
  - ii) Acid gas emission test as per IEC-754 Part-I
  - iii) Smoke density test as per ASTM-D-2843
  - iv) Flammability test as per IEC-332 Part-I or IS-10810
- 8.3 All the above mentioned tests shall be carried out in the presence of purchaser's representative. In addition, the cables shall be subjected to stage inspection at works and inspection at site for final acceptance.
- 8.4 These tests and inspections shall, however, not absolve the vendor from their responsibility for making good any defect which may be noticed subsequently.

**9.0 DRAWINGS AND DOCUMENTS**

- 9.1 Drawings and documents as per Annexure-I shall be supplied, unless otherwise specified.
- 9.2 All drawings and documents shall have the following descriptions written boldly.

- Name of client

**ENGINEERING STANDARD****ES: 8160****2**

DOCUMENT NO.

REV.

**CABLES**

SHEET 7 OF 8

- Name of consultant
- Enquiry / Order Number with plant / project name
- Code No. and Description

**10.0 DEVIATIONS**

10.1 Deviations, if any, from this standard shall be clearly indicated in the offer with reasoning.

10.2 Deviations, if any, from the data furnished in specification sheet shall be indicated therein beside the data by encircling it.



## ANNEXURE - I

## DOCUMENTATION FOR CABLES

Sl. No.	Document Description	Documents Required (Y / N)		
		With Bid	For Approval	Final
1.	Specification Sheet, duly completed	N	Y	Y
2.	Technical Particulars, duly filled-in	N	Y	Y
3.	Illustrative and Descriptive catalogues	N	N	Y
4.	Installation, Termination and Jointing Instructions	N	N	Y
5.	Test certificates			
	a) Routine	N	N	Y
	b) Type	N	N	Y
6.	Guarantee Certificates	N	N	Y

**Note:**

- 1.
2. 4 hard copies & 1 soft copy shall be supplied for approval after order within 4 weeks from the date of LOI.
3. 8 hard copies & 2 soft copies in CD shall be submitted as final documents prior to despatch of the equipment. These shall be made in sets and supplied in fine plastic coated folder.

Y - Yes, N - No



# GENERAL NOTES ON EARTHING AND LIGHTNING PROTECTION

PDSE: 601	0
DOCUMENT NO.	REV
SHEET 1 OF 2	

## A. GENERAL

1. EARTHING AND LIGHTNING PROTECTION SHALL BE CARRIED OUT IN ACCORDANCE WITH IS : 3043 AND IS : 2309 RESPECTIVELY AND SHALL ALSO CONFORM TO THE REQUIREMENTS OF INDIAN ELECTRICITY RULES.
2. THESE NOTES SHALL BE READ IN CONJUNCTION WITH EARTHING & LIGHTNING PROTECTION LAYOUT DRGS. AND RELEVANT EARTHING STANDARDS (PDSE)
3. THE SIZE OF EARTH CONDUCTORS & SYMBOLS SHOWN IN THE LAYOUT DRGS. SHALL AS PER PDSE: 602
4. AS FAR AS POSSIBLE, THE EARTH CONDUCTORS SHALL BE TAKEN ALONG POWER & CONTROL CABLE ROUTES.
5. EARTHING CONDUCTORS BURIED UNDER THE GROUND SHALL BE LAID ATLEAST 500 MM BELOW THE GROUND LEVEL UNLESS REQUIRED OTHERWISE, e.g FOR CROSSING ANY UNDER GROUND PIPE OR TRENCH ETC. WHERE THE EARTHING CONDUCTORS SHALL RUN AT A MINIMUM DEPTH 300 MM BELOW THE BOTTOM OF THE PIPE/TRENCH.
6. BARE ALUMINIUM CONDUCTORS SHALL NOT BE BURIED DIRECTLY UNDER THE GROUND.
7. TAPPING FROM THE UNDER GROUND EARTH GRID SHALL BE TAKEN ONLY FROM EARTH PIT OR A PIT WITHOUT ELECTRODE PROVIDED FOR THIS PURPOSE.
8. JOINTING OF UNDERGROUND EARTHING STRIPS SHALL BE AVOIDED TO THE EXTENT POSSIBLE. HOWEVER, IF JOINTING IS TO BE DONE DUE TO UNAVOIDABLE REASONS, THIS SHALL BE DONE BY ELECTRIC ARC WELDING.
9. TERMINAL JOINTING & CLAMPING ARRANGEMENT SHALL BE AS SHOWN IN PDSE:603. ALL WELDED OR BOLTED JOINTS SHALL BE PAINTED WITH EPOXY RESIN PAINT OR BITUMINOUS PAINT.
10. EARTH BUSES, AS PER CONVENIENCE, SHALL BE PROVIDED IN PLANTS FOR EARTHING GROUPS OF EQUIPMENT TO EARTHING GRID. THESE EARTH BUSES, SHALL BE AS SHOWN IN PDSE: 615.
11. DETAILS OF EARTH PIT CONNECTIONS & ACCESSORIES FOR EARTH ELECTRODES SHALL BE AS SHOWN IN PDSE :604, 605 , 610 AND 611.
12. EARTH PITS FOR EQUIPMENT EARTHING, SYSTEM NEUTRAL EARTHING & LIGHTNING PROTECTION SHALL BE SEPARATE. HOWEVER, THESE PITS SHALL BE INTERCONNECTED.
13. SPACING BETWEEN TWO EARTH PITS SHALL NOT BE LESS THAN 10 M & THESE MAY BE LOCATED ABOUT 4M AWAY FROM THE BUILDING / STRUCTURE.
14. TYPICAL ARRANGEMENT OF NEUTRAL & EQUIPMENT EARTHING SHALL BE AS SHOWN IN PDSE: 617.

## B. SYSTEM NEUTRAL EARTHING

1. THE NEUTRALS OF H.T & L.T SYSTEMS SHALL BE EARTHED BY USING 2 NOS. 150 SQ. MM ALUMINIUM CABLE OF RESPECTIVE VOLTAGE GRADE. EACH EARTH CONNECTION SHALL BE TERMINATED ON SEPERATE EARTH PITS. HOWEVER, FOR ECONOMY REASONS, 2 EARTH CONNECTIONS OF 2 DIFFERENT EQUIPMENT CAN BE TERMINATED ON THE SAME EARTH PIT AS SHOWN IN PDSE: 617.
2. THE NEUTRAL OF H.T. SYSTEM SHALL BE CONNECTED TO EARTH PIT AS ABOVE THROUGH THE NEUTRAL EARTHING RESISTOR (N.E.R.) AS REQUIRED, WHERE AS THE NEUTRAL OF L.T. SYSTEM SHALL BE SOLIDLY EARTHED THROUGH RESPECTIVE L.T. SWITCH BOARD.
3. FOR D.C. SYSTEM, POSITIVE POLE SHALL BE EARTHED THROUGH HIGH IMPEDANCE IN BATTERY CHARGER.

## C. ELECTRICAL EQUIPMENT EARTHING

1. ALL EQUIPMENT RATED ABOVE 250V SHALL HAVE TWO EXTERNAL EARTH CONNECTIONS & THOSE RATED 250V & BELOW SHALL HAVE ONE EXTERNAL EARTH CONNECTION.  
FLAME PROOF EQUIPMENT, IN ADDITION, SHALL HAVE ONE INTERNAL EARTH CONNECTION THROUGH ADDITIONAL CORE OF POWER / CONTROL CABLE.

0	03.01.07	15.01.07	ISSUED FOR IMPLEMENTATION			
REV	REV.DATE	EFF.DATE	PURPOSE	PREPD	REVWD	APPD



# GENERAL NOTES ON EARTHING AND LIGHTNING PROTECTION

PDSE: 601	0
DOCUMENT NO.	REV
SHEET 2 OF 2	

- EARTHING CONNECTION TO INDIVIDUAL EQUIPMENT SHALL BE TAPPED ONLY FROM THE EARTHING GRID / RING OR EARTH BUS EXCEPT FOR EQUIPMENT RATED 250V & BELOW, FOR WHICH THE CONNECTION MAY BE TAKEN FROM THE NEAR BY EARTH CONDUCTOR OF A LARGER EQUIPMENT OR FROM THE BODY OF THE LARGER EQPT.
- EARTHING ARRANGEMENT OF MOTOR AND ASSOCIATED LOCAL CONTROL STATION SHALL BE AS SHOWN IN PDSE: 608.
- EARTHING ARRANGEMENT OF RAILS SHALL BE AS SHOWN IN PDSE: 609 WITH BOTH ENDS EARTHED.
- CABLES RACKS/RISERS/TRAYS SHALL BE ELECTRICALLY CONTINUOUS BY BONDING THE JOINTS BETWEEN THE RUNNER MEMBERS OF THE ADJACENT SECTIONS. THE CABLE RACKS SHALL BE CONNECTED TO THE EARTHING GRID AT SUITABLE INTERVALS.
- EARTHING ARRANGEMENT OF LIGHTING FIXTURES & PLUG SOCKETS RATED 250V AND BELOW SHALL NOT BE SHOWN IN THE EARTHING LAYOUT DRGS. HOWEVER, PLUG SOCKETS SHALL BE EARTHED BY 10 SWG SIZE G.I./AL. CONDUCTOR TAKEN FROM THE NEAREST EARTHING GRID/CONDUCTOR AND LIGHTING FIXTURES SHALL BE PROVIDED EARTHING THROUGH CABLE ARMOURS.
- IN SWITCH YARD AND GENERATING STATIONS SUITABLE EARTHING MAT SHALL BE PROVIDED TO REDUCE THE VALUE OF STEP/TOUCH POTENTIAL TO PERMISSIBLE VALUE.
- SWITCH YARD FENCE SHALL BE CONNECTED TO EARTH AT A REGULAR INTERVAL, NOT EXCEEDING 10 M.

## D. STATIC EARTHING

- ALL PROCESS EQUIPMENT WHICH ARE LIKELY TO GET STATICALLY CHARGED, e.g. STORAGE TANKS, HIGH PRESSURE & MEDIUM PRESSURE VESSELS/PIPES, HIGH PRESSURE COMPRESSORS. HIGH PRESSURE STEAM EJECTORS ETC. SHALL BE EARTHED AGAINST STATIC CHARGE ACCUMULATION.
- EARTHING ARRANGEMENT ACROSS PIPE JOINTS/VALVES SHALL BE AS SHOWN IN PDSE: 612
- DETAILS OF EARTHING OF VESSELS SHALL BE AS SHOWN IN PDSE: 613.
- MOBILE EQUIPMENT, REQUIRING EARTHING AGAINST STATIC CHARGE, SHALL BE TEMPORARILY EARTHED AS SHOWN IN PDSE: 608.
- PIPE TRESTLE CARRYING PIPES WITH HYDRO CARBONS SHALL BE CONNECTED TO EARTH GRID AT REGULAR INTERVALS, NOT EXCEEDING 25 M.
- WHEREVER PROCESS EQUIPMENT ARE MOUNTED ON STEEL STRUCTURE, THE BASE OF THE STRUCTURES SHALL BE EARTHED INSTEAD OF EARTHING THE INDIVIDUAL EQUIPMENT.

## E. LIGHTNING PROTECTION

- FIXING ARRANGEMENT ON AIR TERMINATION AND ROOF/DOWN CONDUCTOR FOR LIGHTNING PROTECTION SYSTEM SHALL BE AS SHOWN IN PDSE: 614.
- FOR LIGHTNING PROTECTION OF TALL STEEL STRUCTURES/VESSELS/TANKS, DOWN CONDUCTOR SHALL BE TAKEN FROM THE BASE AND CONNECTED TO EARTH PITS. AIR TERMINATION ROD SHALL NOT BE REQUIRED.
- LIFT SHAFT SHALL NOT BE USED FOR FIXING THE DOWN CONDUCTOR.
- IN CASE EARTH PITS FOR CONNECTING THE DOWN CONDUCTORS ARE NOT AVAILABLE IN THE BEGINNING OF FABRICATION/ERECTION OF SUCH STRUCTURES/VESSELS / TANKS. THEIR BASES SHALL TEMPORARILY BE CONNECTED TO NEAR BY STEEL COLUMN. ELECTRICAL CONTINUITY OF THE STRUCTURES, HOWEVER, SHALL BE CHECKED AND ENSURED.
- FOR ALL HIGH RISE CONCRETE STRUCTURES, TEMPORARY LIGHTNING PROTECTION NEED BE PROVIDED DURING CONSTRUCTION AND MAINTAINED TILL PERMANENT LIGHTNING PROTECTION IS INSTALLED. FOR THIS PURPOSE THE VERTICAL REINFORCEMENT, PROJECTING OVER EACH LIFT, SHALL BE CONNECTED TO EARTH PITS BY MEANS OF 2 NOS. FLEXIBLE COPPER CONDUCTOR CABLES. EACH OF THE FLEXIBLE CABLE SHALL BE OF 95 Sq. mm SIZE HAVING ONE END PERMANENTLY CONNECTED TO EARTH PIT AND OTHER END PROVIDED WITH A CLAMP FOR CONNECTING TO THE EXPOSED REINFORCEMENT.

0	03.01.07	15.01.07	ISSUED FOR IMPLEMENTATION	<i>US</i> NKR	<i>Amul</i> AV	<i>BB</i> BB
REV	REV.DATE	EFF.DATE	PURPOSE	PREPD	REVWD	APPD





ARRANGEMENT OF CONNECTIONS  
OF EARTH CONDUCTORS  
(T-JOINT AL STRIP & GI STRIP TO ROUND AL CONDUCTOR)

PDS:E 603	0
DOCUMENT NO.	REV
SHEET 1 OF 6	

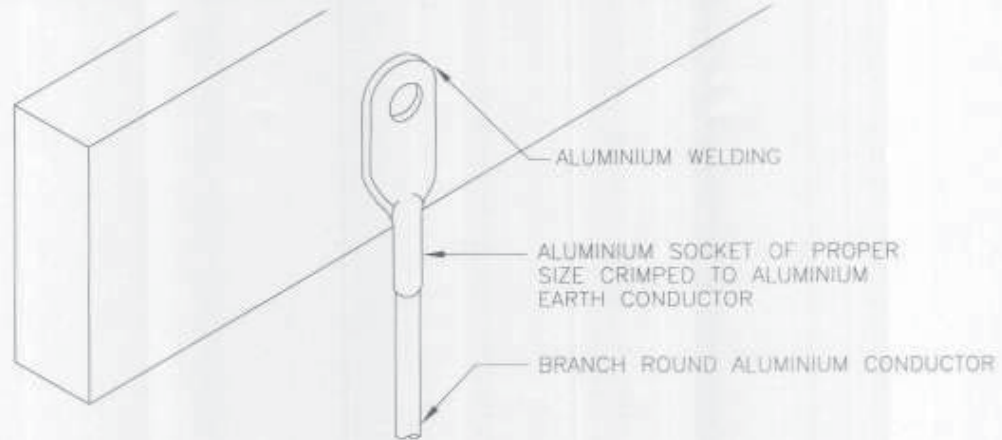

' T ' JOINT ALUMINIUM STRIP TO ROUND ALUMINIUM CONDUCTOR

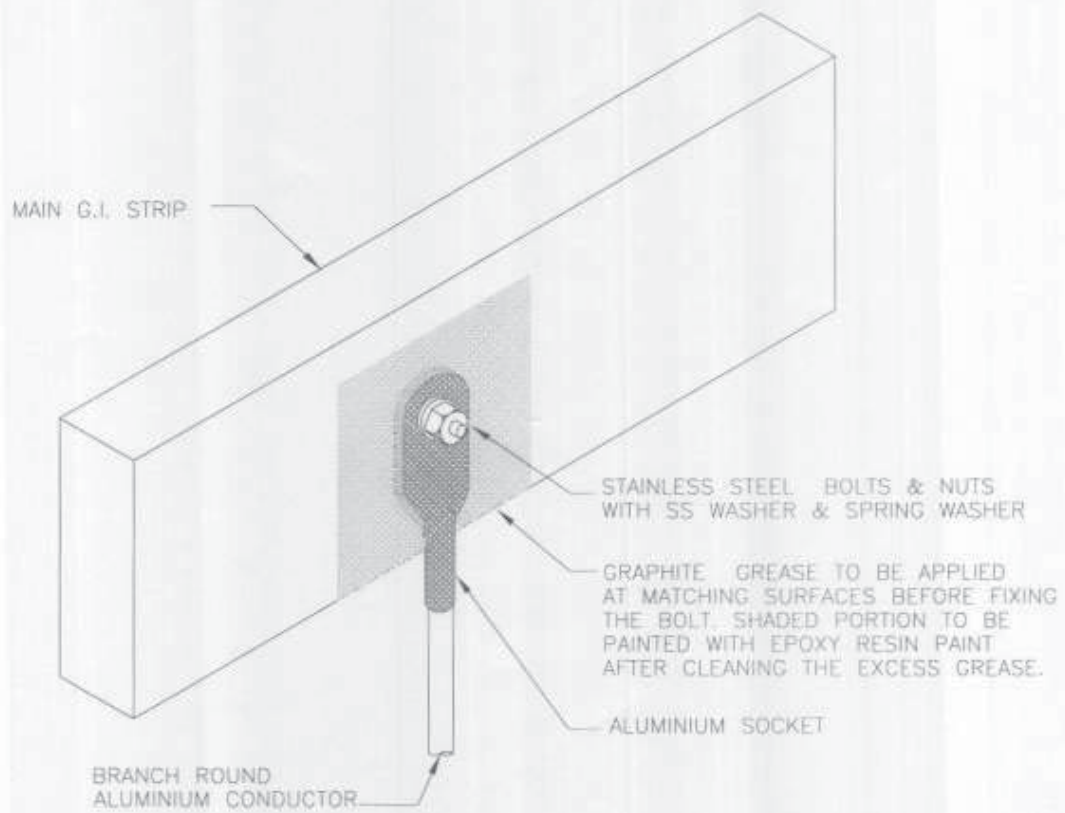

' T ' JOINT G.I. STRIP TO ROUND ALUMINIUM CONDUCTOR

0	03.01.07	15.01.07	ISSUED FOR IMPLEMENTATION	<i>[Signature]</i> NKR	<i>[Signature]</i> AV	<i>[Signature]</i> BB
REV	REV.DATE	EFF.DATE	PURPOSE	PREPD	REVWD	APPD





ARRANGEMENT OF CONNECTIONS OF EARTH CONDUCTORS

( TERMINATION OF ROUND EARTH CONDUCTOR AT EQUIPMENT)

PDS:E 603

0

DOCUMENT NO.

REV

SHEET 2 OF 6

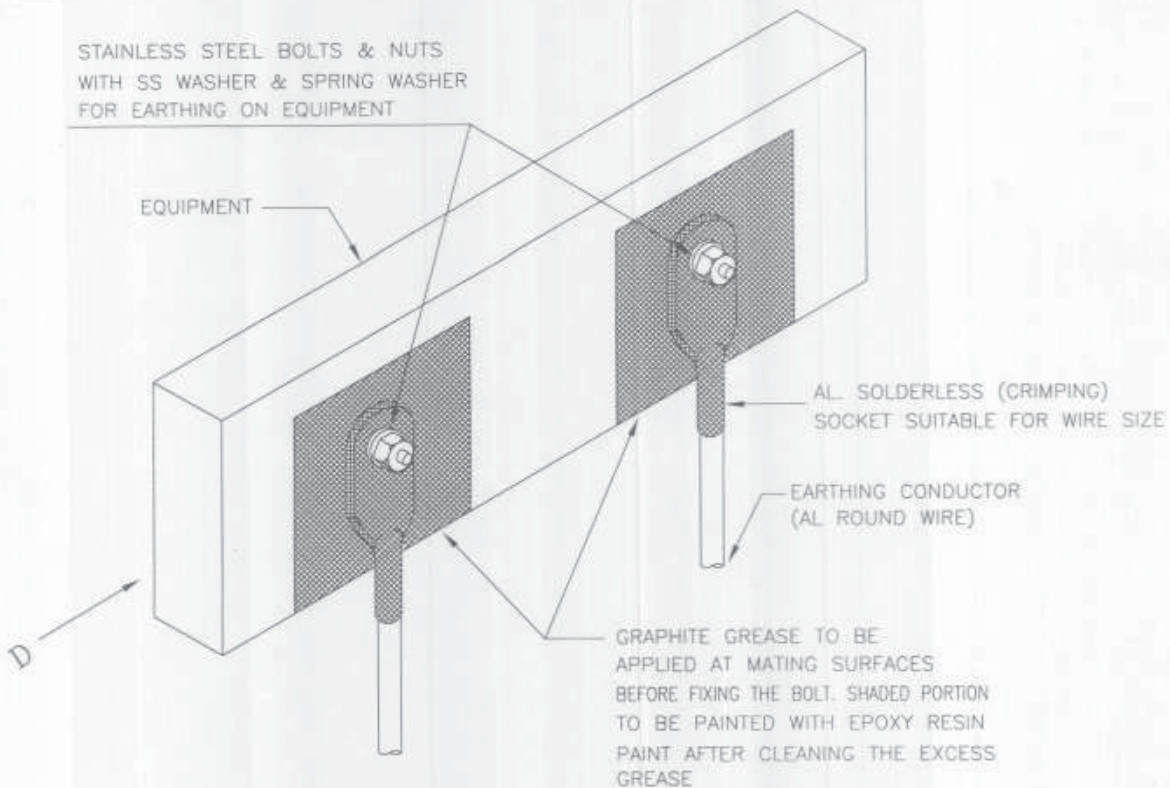

ARRANGEMENT OF DOUBLE EARTH CONNECTIONS TO EQUIPMENT

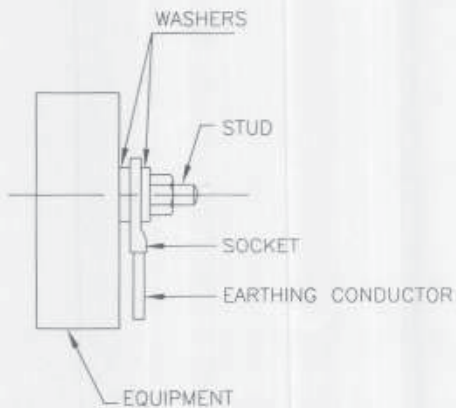

VIEW FROM - D

0	03.01.07	15.01.07	ISSUED FOR IMPLEMENTATION	<i>NKR</i>	<i>BB</i>	<i>BB</i>
REV	REV.DATE	EFF.DATE	PURPOSE	PREPD	REVWD	APPD



ARRANGEMENT OF CONNECTIONS OF EARTH CONDUCTORS  
(STRAIGHT & T - JOINT G.I. & AL. STRIP)

PDS:E 603	0
DOCUMENT NO.	REV
SHEET 3 OF 6	

HATCHED PORTION TO BE PAINTED  
WITH BITUMINOUS PAINT AND TAPPED  
WITH BITUMINOUS HESIAN TAPE AFTER  
WELDING TO PREVENT CORROSION

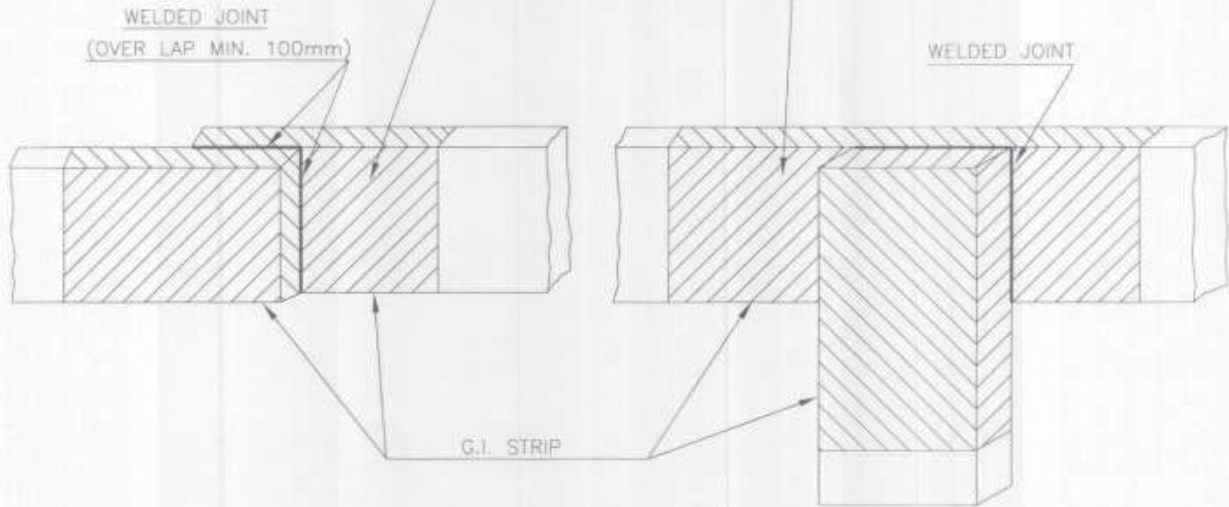

STRAIGHT JOINT G.I. TO G.I. STRIP

" T " JOINT G.I. TO G.I. STRIP

ALUMINIUM STRIP SHOULD BE CLEANED  
BEFORE WELDING THE COMPLETED JOINT  
SHOULD BE PAINTED WITH EPOXY

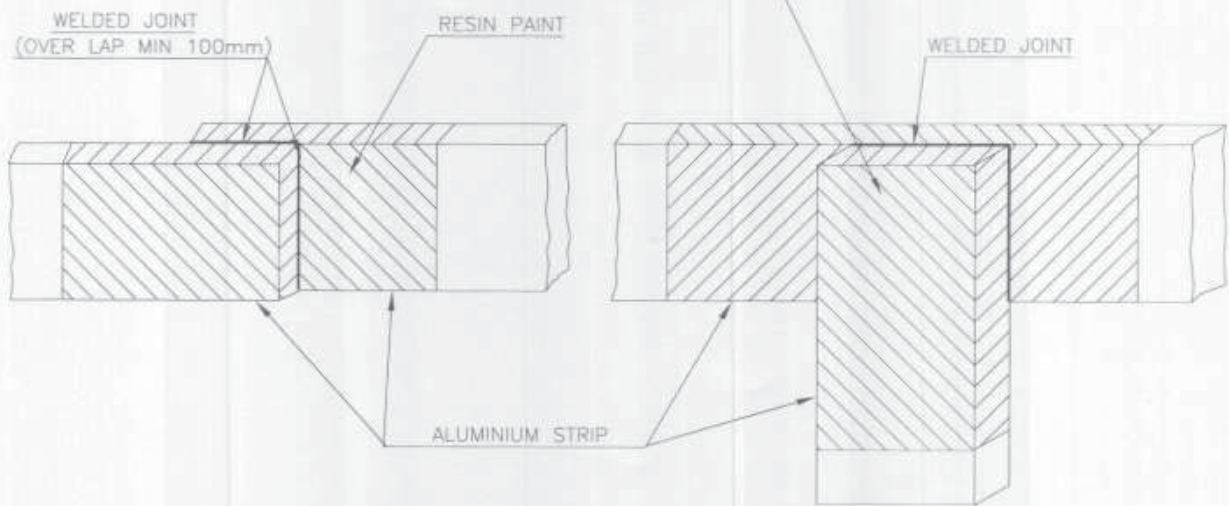

STRAIGHT JOINT AL. TO AL. STRIP

" T " JOINT AL TO AL STRIP

0	03.01.07	15.01.07	ISSUED FOR IMPLEMENTATION	<i>[Signature]</i> NKR	<i>[Signature]</i> HV	<i>[Signature]</i> BB
REV	REV.DATE	EFF.DATE	PURPOSE	PREPD	REVWD	APPD

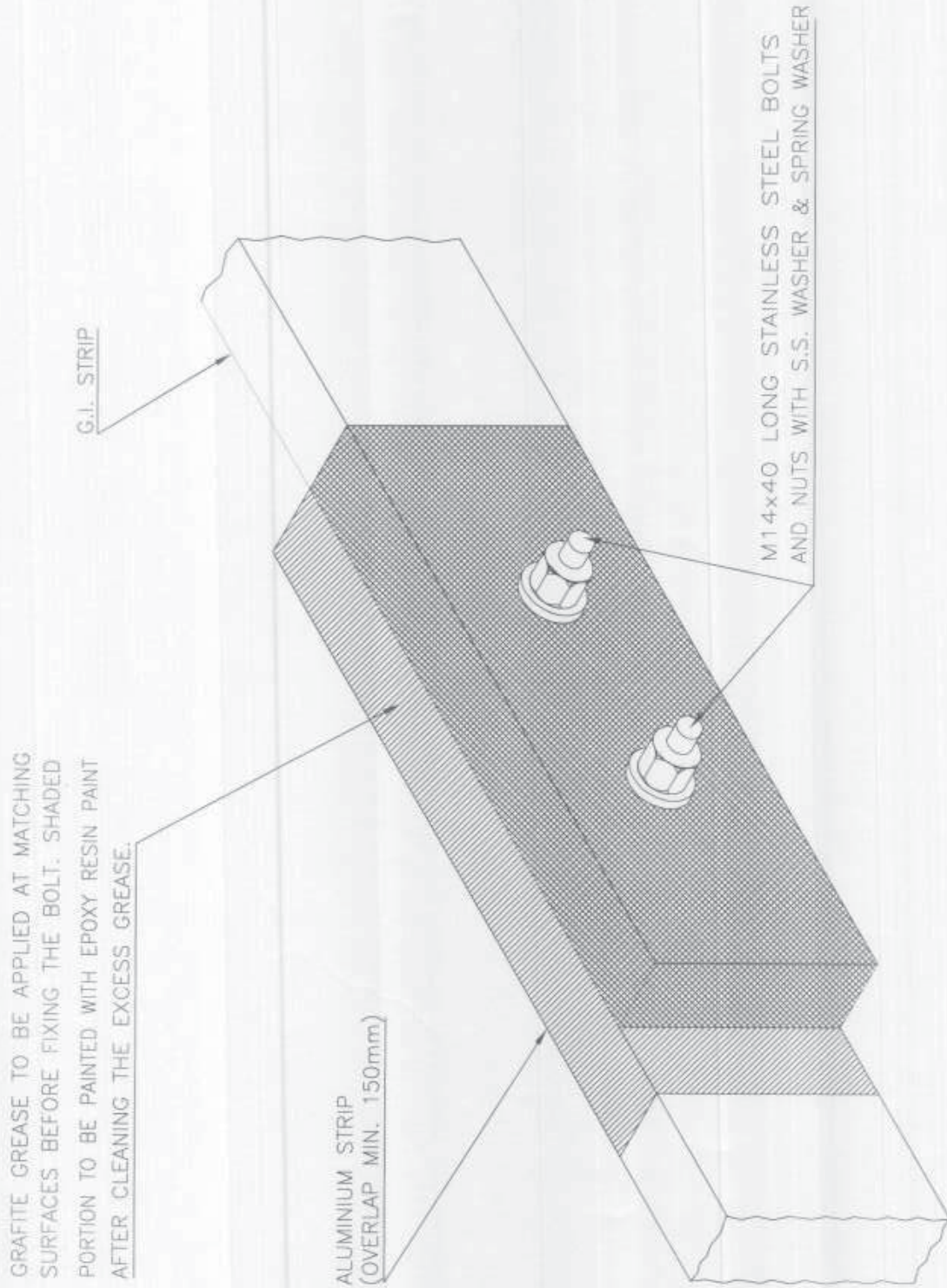

ARRANGEMENT OF LAP JOINT BETWEEN  
AL. EARTH STRIP TO G.I. EARTH STRIP

0	03.01.07	15.01.07	ISSUED FOR IMPLEMENTATION	<i>[Signature]</i> NKR	<i>[Signature]</i> V	<i>[Signature]</i> BB
REV	REV.DATE	EFF.DATE	PURPOSE	PREPD	REVWD	APPD



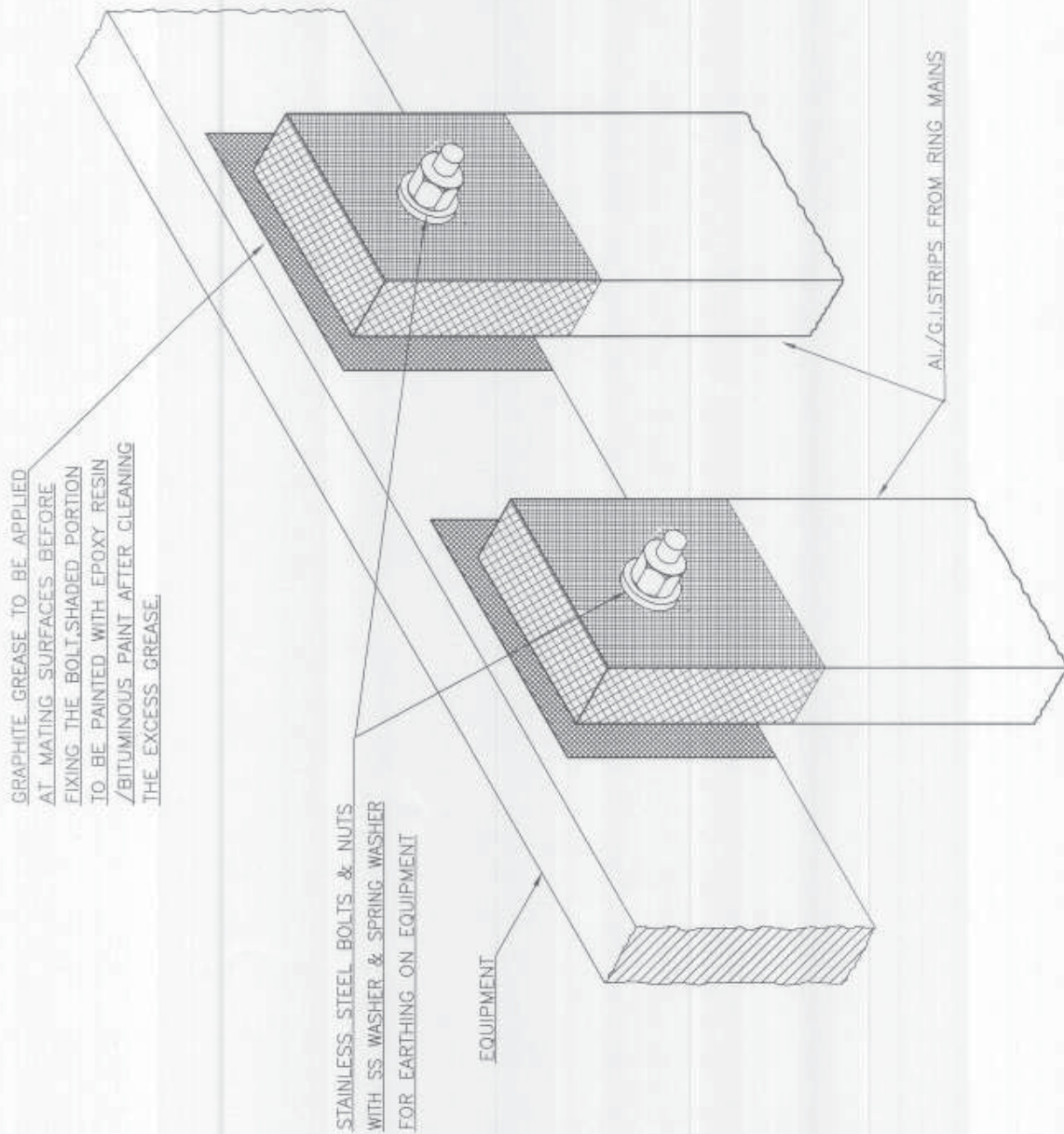

ARRANGEMENT OF DOUBLE EARTH CONNECTION ON EQUIPMENT

NOTE:-

EPOXY RESIN PAINT SHALL BE USED FOR AL STRIP AND BITUMINOUS PAINT FOR G.I. STRIP.

0	03.01.07	15.01.07	ISSUED FOR IMPLEMENTATION			
REV	REV.DATE	EFF.DATE	PURPOSE	PREPD	REVWD	APPD



ARRANGEMENT OF CONNECTIONS OF EARTH CONDUCTORS  
(CRIMPING OF ROUND TO ROUND ALUMINIUM CONDUCTORS)

PDS:E 603	0
DOCUMENT NO.	REV
SHEET 6 OF 6	

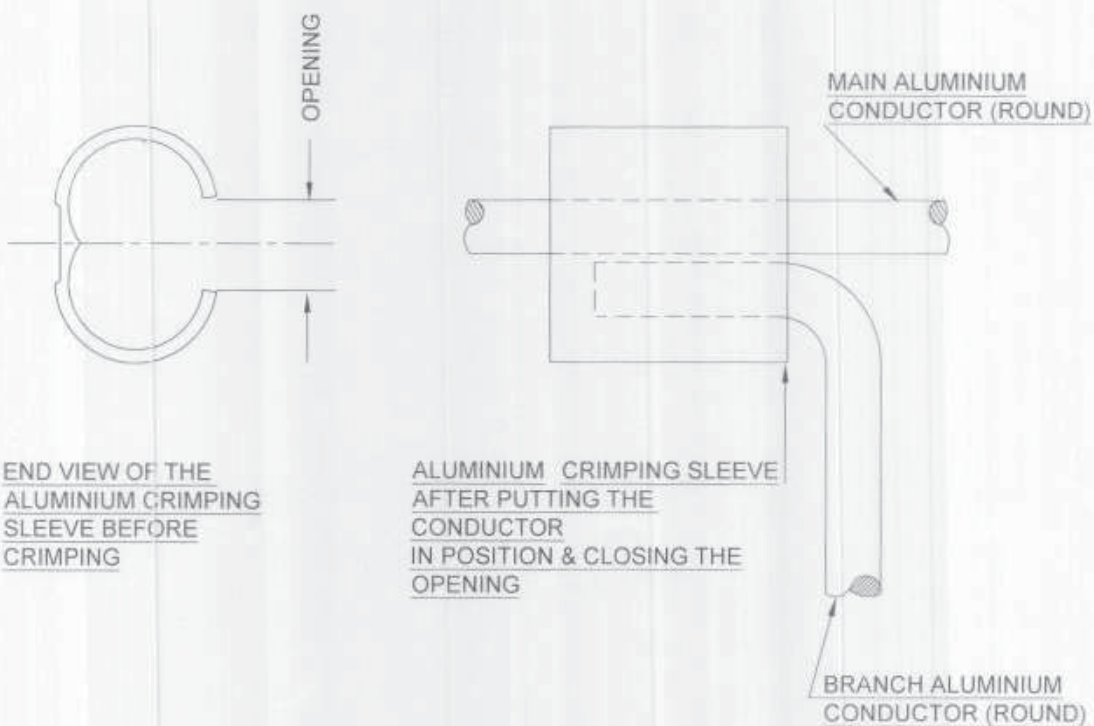

"T" JOINT ROUND ALUMINIUM CONDUCTOR TO ROUND ALUMINIUM CONDUCTOR ( CRIMPING TYPE )

NOTE :-

USE CORRECT SIZE OF COMPRESSION DIES.

0	03.01.07	15.01.07	ISSUED FOR IMPLEMENTATION	NKR		BB
REV.	REV.DATE	EFF.DATE	PURPOSE	PREPD	REVWD	APPD



# TYPICAL DETAILS OF CONNECTIONS IN EARTH PIT

PDS:E 604

0

DOCUMENT NO.

REV

SHEET 1 OF 1

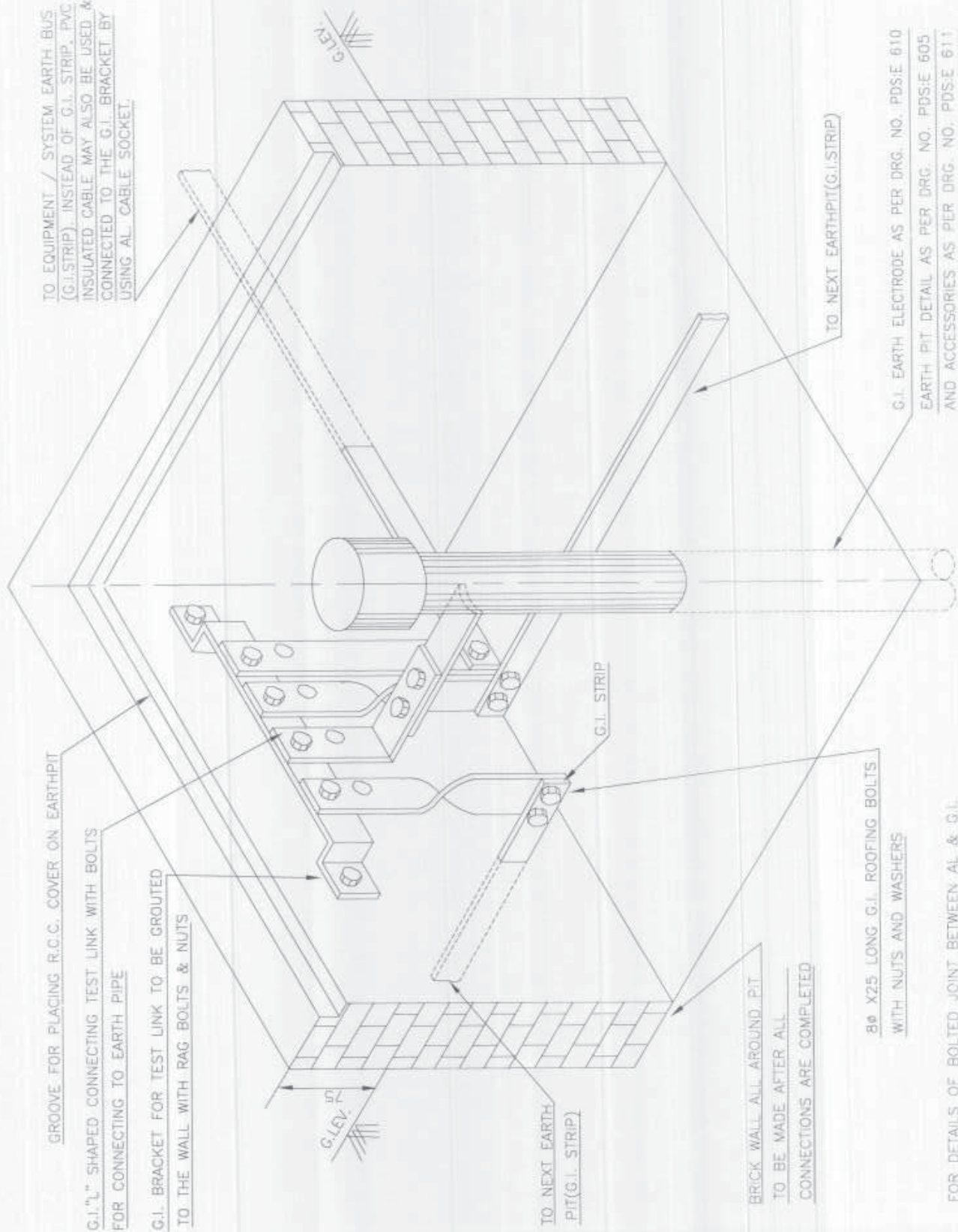

0	03.01.07	15.01.07	ISSUED FOR IMPLEMENTATION	<i>DKR</i> NKR	<i>Shree</i> V	<i>BCA</i> BB
REV	REV.DATE	EFF.DATE	PURPOSE	PREPD	REVWD	APPD





# EARTH PIT DETAILS

PDS:E 605	0
DOCUMENT NO.	REV
SHEET 1 OF 2	

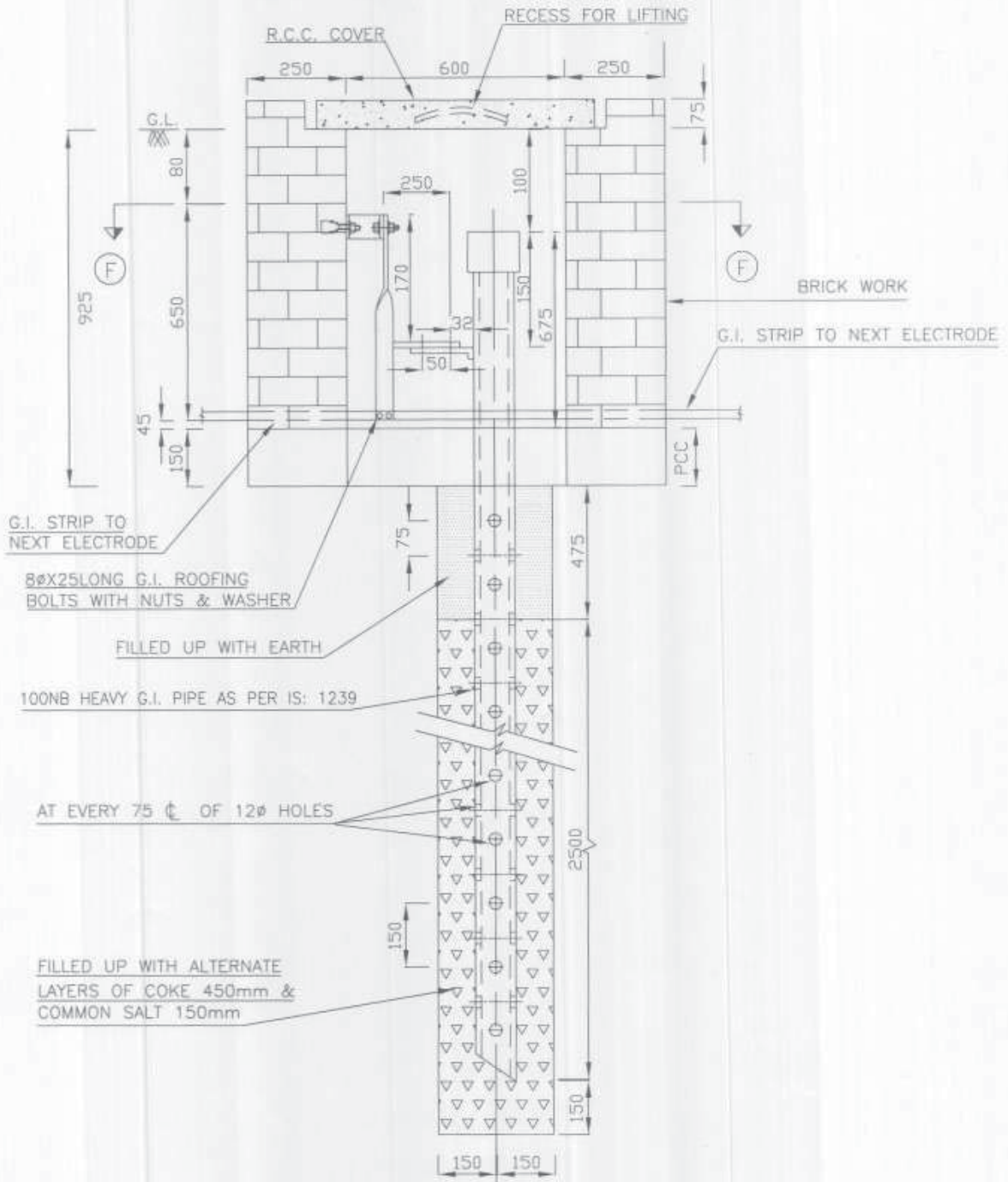

SECTIONAL ELEVATION OF EARTH PIT

0	03.01.07	15.01.07	ISSUED FOR IMPLEMENTATION	<i>NKR</i>	<i>AV</i>	<i>BB</i>
REV	REV.DATE	EFF.DATE	PURPOSE	PREPD	REVWD	APPD





# EARTH PIT DETAILS

PDS:E 605	0
DOCUMENT NO.	REV
SHEET 2 OF 2	

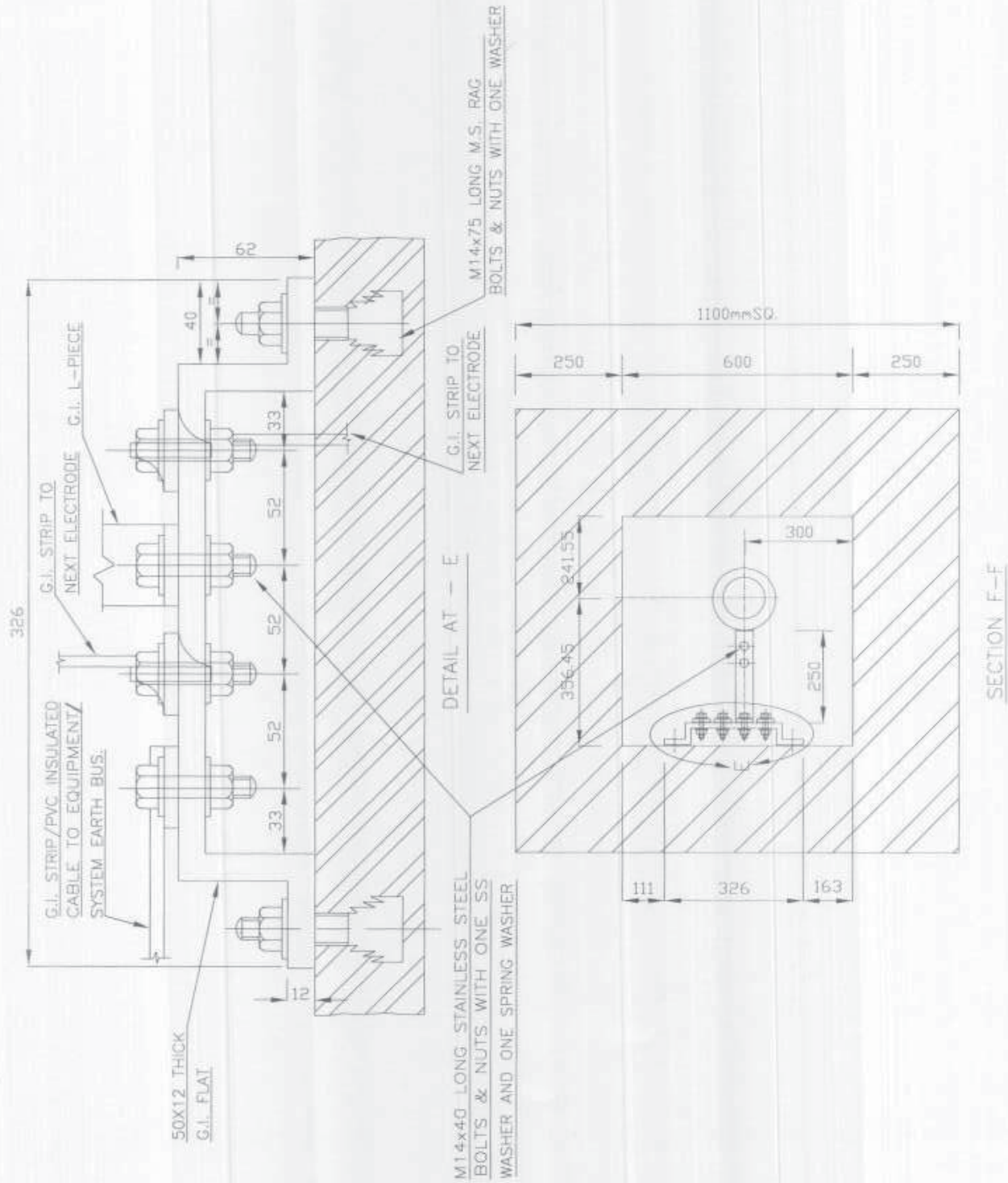

0	03.01.07	15.01.07	ISSUED FOR IMPLEMENTATION	<i>NKR</i>	<i>AV</i>	<i>BB</i>
REV	REV.DATE	EFF.DATE	PURPOSE	PREPD	REVWD	APPD



# 3.8M G.I. ELECTRODE FOR EARTHING

PDS:E 610

1

DOCUMENT NO.

REV

SHEET 1 OF 1

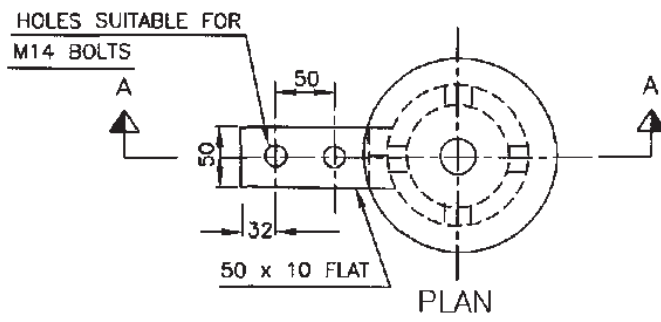
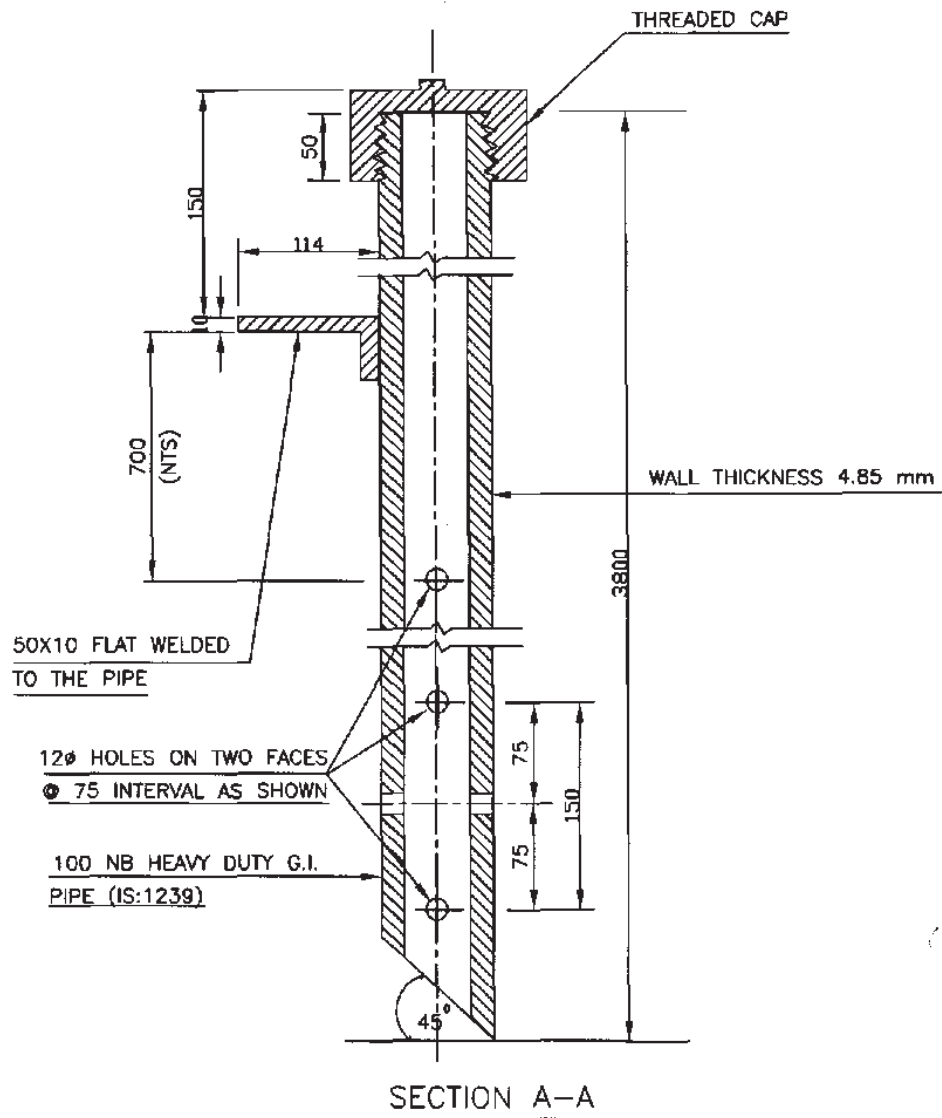

**NOTE:-**

- 12 $\phi$  HOLES WILL BE PROVIDED AT 75mm INTERVAL ON TWO FACES THROUGHOUT THE LENGTH OF PIPE. THE FIRST ONE SHALL START 700mm BELOW THE WELDED FLAT.
- ALL DIMENSIONS ARE IN mm.

1	16.01.06	30.01.06	ISSUED FOR IMPLEMENTATION	<i>[Signature]</i> RUNDA	<i>[Signature]</i> AV	<i>[Signature]</i> BB
REV	REV.DATE	EFF.DATE	PURPOSE	PREPD	REVWD	APPD



GI / AL. ACCESSORIES FOR  
EARTH PIT

PDS:E 611	0
DOCUMENT NO.	REV
SHEET 1 OF 2	

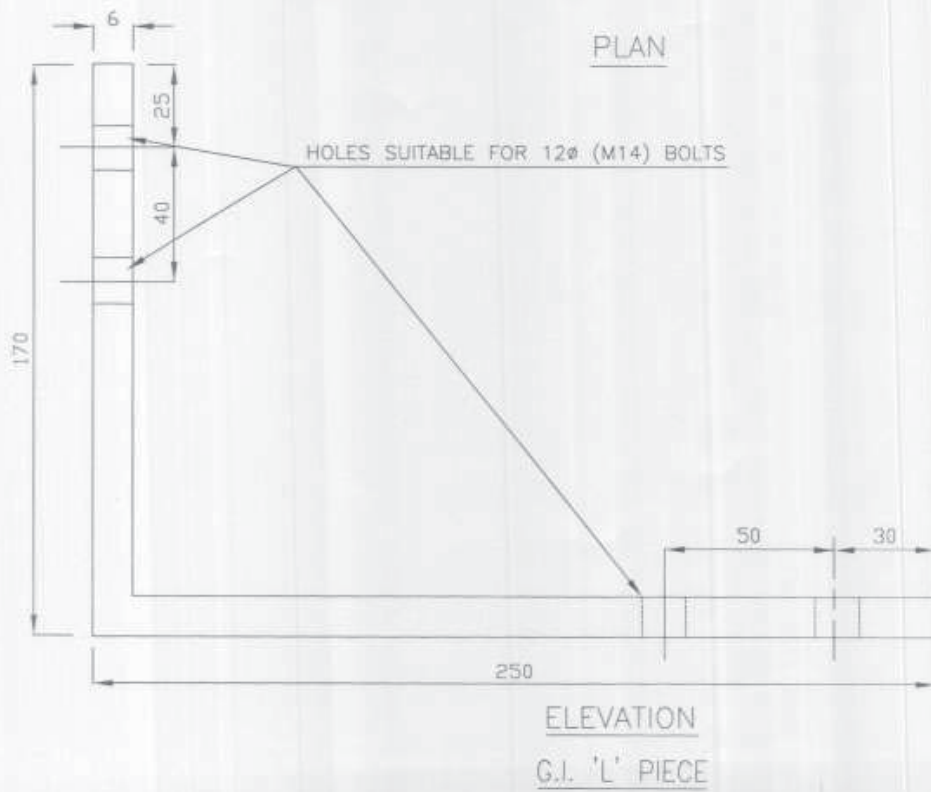
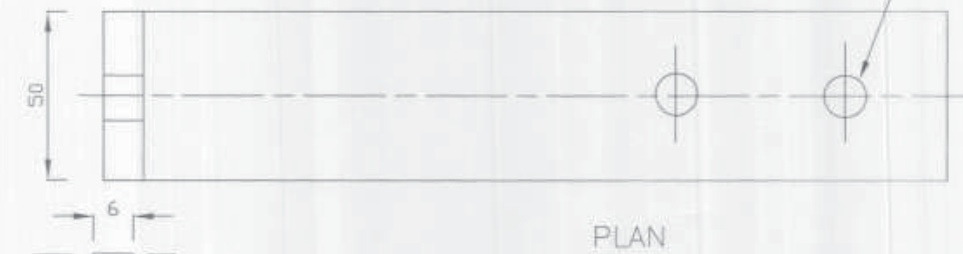
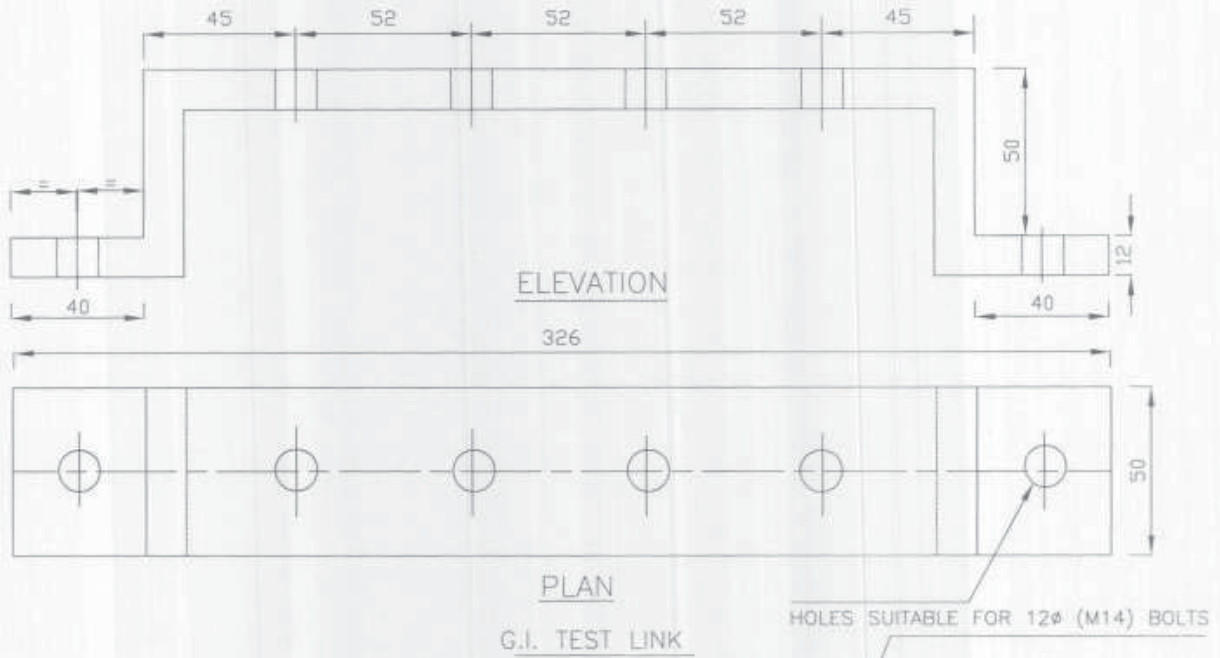

0	03.01.07	15.01.07	ISSUED FOR IMPLEMENTATION	<i>NKR</i>	<i>AV</i>	<i>BB</i>
REV	REV.DATE	EFF.DATE	PURPOSE	PREPD	REVWD	APPD



GI/AL. ACCESSORIES FOR  
EARTH PIT

PDS:E 611	0
DOCUMENT NO.	REV
SHEET 2 OF 2	

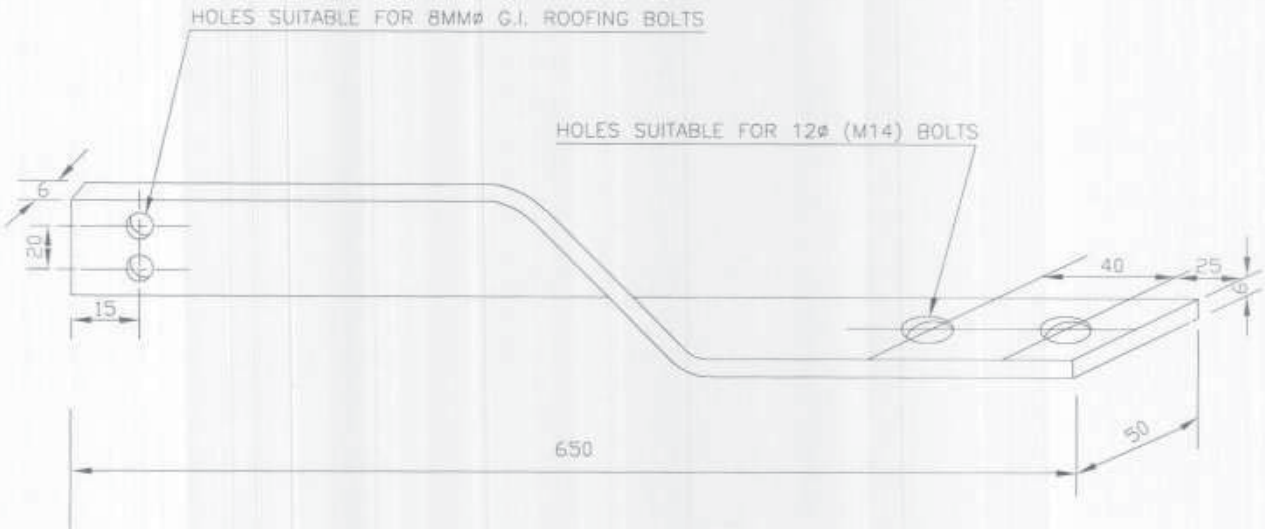

CONNECTING TWISTED ALUMINIUM FLAT PIECE

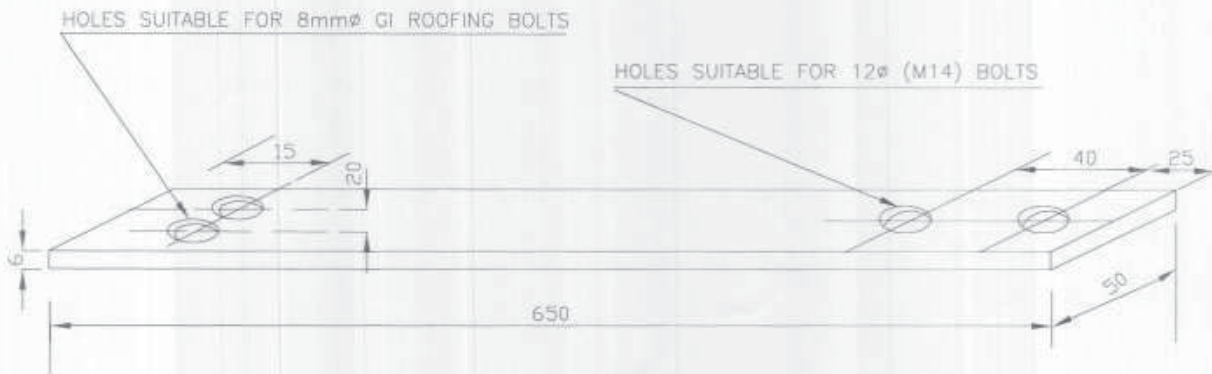

CONNECTING ALUMINIUM / G.I. FLAT PIECE

0	03.01.07	15.01.07	ISSUED FOR IMPLEMENTATION	<i>NKR</i>	<i>AV</i>	<i>BB</i>
REV	REV.DATE	EFF.DATE	PURPOSE	PREPD	REVWD	APPD





# TYPICAL ARRANGEMENT FOR NEUTRAL AND EQUIPMENT EARTHING

PDS:E 617

1

DOCUMENT NO.

REV

SHEET 1 OF 1

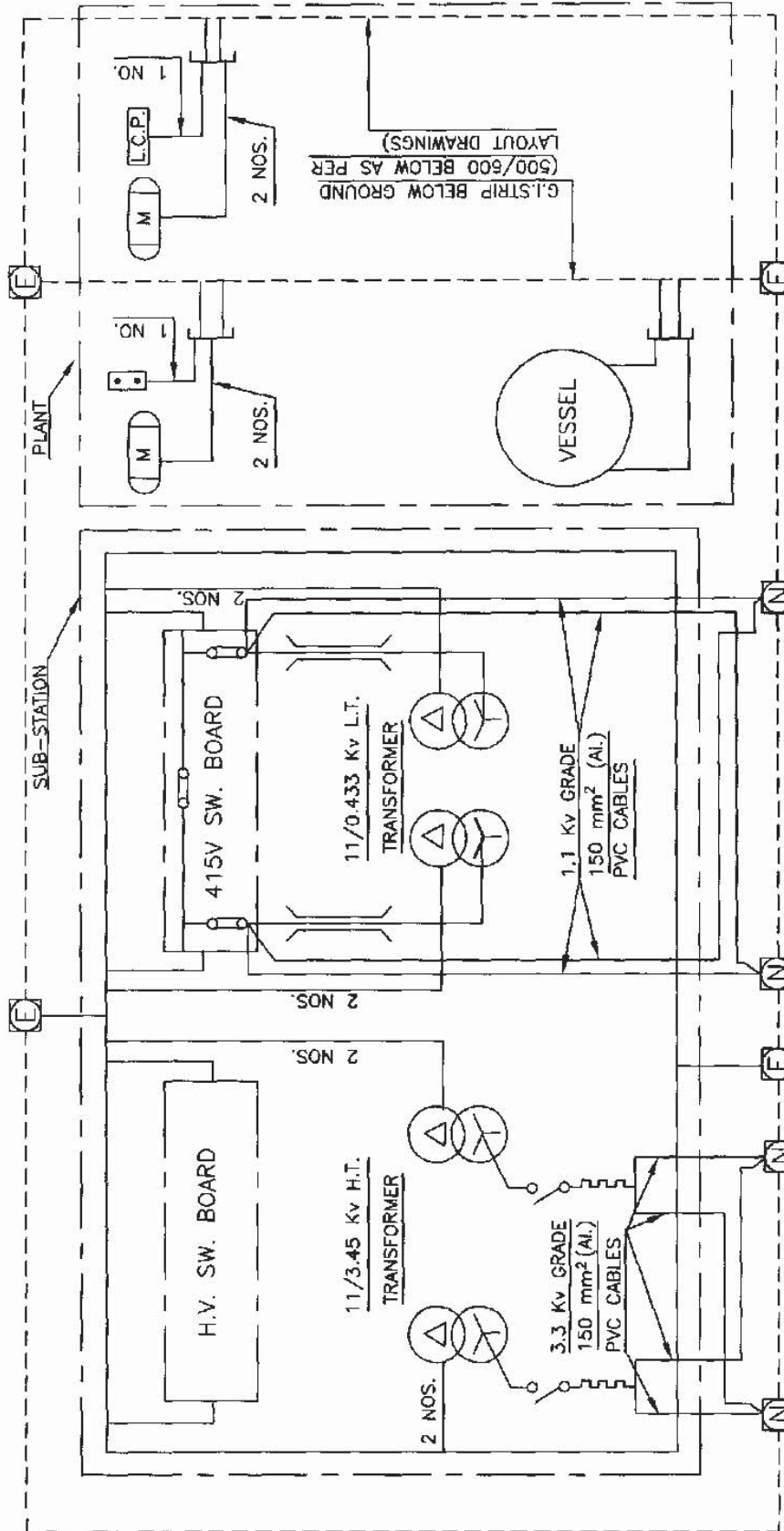

**REF. DRGS.**

1. EARTH PIT DETAILS - PDS:E 605
2. EARTH CONDUCTOR SIZES - PDS:E 602 (2 SHEETS)



**NOTE :-**

EARTH BUS SHALL BE 500 ABOVE FROM FLOOR LEVEL

**LEGEND**

- MOTOR
- LOCAL CONTROL PANEL
- LOCAL CONTROL STATION
- NEUTRAL EARTH PIT
- EARTH PIT FOR SYSTEM
- NEUTRAL LINK
- TPN BUS DUCT
- NEUTRAL EARTHING RESISTOR
- SWITCH
- EARTH BUS

1	16.01.06	30.01.06	ISSUED FOR IMPLEMENTATION		RUNDA		ANAND AV		BB
REV	REV.DATE	EFF.DATE	PURPOSE	PREPD		REVWD		APPD	

	<p align="center"><b>ELECTRICAL WORKS (SUPPLY &amp; ERECTION) FOR ALTERNATE POWER SUPPLY ARRANGEMENT OF VIKARMPUR GUEST HOUSE AT TALCHER FERTILIZERS LTD., ANGUL, ODISHA</b></p> <p align="center"><b>SCHEDULE OF RATES</b></p>	PC-183/E/ 8001 /S-VII	0	
		DOC. NO.	REV	
		Page 1 of 115		

**SCHEDULE OF RATES**

**SECTION VII**

**ATTENTION**

**THIS IS AN ELECTRONIC TENDER BIDDER TO QUOTE AS PER  
PROVIDED BOQ (.XLS) IN CPP PORTAL ONLY**

[Validate](#)[Print](#)[Help](#)

## Item Rate BoQ

Tender Inviting Authority: Projects &amp; Development India Limited, Noida

Name of Work: Electrical Works (Supply &amp; Erection) Tender For Alternate Power Supply Arrangement of Vikrampur Guest House At Talcher Fertilizer Complex - Angul

Contract No: PNP/PC 183/E/8001/NCB

**NOTE :** Quantities mentioned in the Schedule of Rates are indicative and not exhaustive in nature. Payment shall be made as per actual quantity used/certified at site by Owner's Engineer-in-charge. Quantities indicated in Schedule of Rates are approximate and subject to variation on either side. The quantity of individual item may be deleted. Contractor shall not be entitled for any compensation on this account and the quoted rates shall hold good for such quantity variations etc. Payments on bills shall, however, be made on actual measurements of quantities of work done as per approved drawings. **Goods & Services Tax (GST) is applicable @ 18% on the quoted rates (being Works Contract).**

Name of the Bidder/ Bidding Firm / Company :	
--	--

**SCHEDULE OF RATES** (This BOQ template must not be modified/replaced by the bidder and the same should be uploaded after filling the relevent columns, else the bidder is liable to be rejected for this tender. Bidders are allowed to enter the Bidder Name and Values only )

NUMBER	TEXT #	NUMBER #	TEXT #	NUMBER #	NUMBER	NUMBER #	NUMBER #	TEXT #
Sl. No.	Item Description	Quantity	Units	BASIC RATE In Figures To be entered by the Bidder in Rs. P	GST @ 18% in RS. P	TOTAL AMOUNT Incl. All taxes & duties (Excl. GST) in Rs. P	TOTAL AMOUNT Incl. All taxes , duties and GST in Rs. P	TOTAL AMOUNT Incl. All taxes, duties and GST In Words
<b>1.0</b>	<b>SUPPLY (PART-I)</b>							
1.01	Supply of 11kV/0.433kV, 250 KVA, ONAN Distribution Transformer along with all accessories as specified in Technical Specification.	1.000	No.		0.00	0.00	0.00	INR Zero Only
1.02	Supply of 3C x 240 sq. mm (Al), 11 KV (UE) Grade, Cable, XLPE Insulated, PVC inner sheathed, Armoured, FRLS PVC outer sheathed cables as specified in Technical Specification.	2250.000	Mtrs		0.00	0.00	0.00	INR Zero Only
1.03	Supply of 3.5 x 300 mm <sup>2</sup> (Al), 1.1 KV Grade,Cable, XLPE Insulated, PVC inner Sheath, Armoured, FRLS PVC outer sheathed cables as specified in Technical Specification .	250.000	Mtrs		0.00	0.00	0.00	INR Zero Only
1.04	Supply of 3 C x 2.5 mm <sup>2</sup> (Cu) , 1.1 KV Grade,Cable, XLPE Insulated, PVC inner Sheath, Armoured, FRLS PVC outer sheathed cables as specified in Technical Specification .	250.000	Mtrs		0.00	0.00	0.00	INR Zero Only



[Validate](#)[Print](#)[Help](#)

## Item Rate BoQ

Tender Inviting Authority: Projects &amp; Development India Limited, Noida

Name of Work: Electrical Works (Supply &amp; Erection) Tender For Alternate Power Supply Arrangement of Vikrampur Guest House At Talcher Fertilizer Complex - Angul

Contract No: PNPM/PC 183/E/8001/NCB

**NOTE :** Quantities mentioned in the Schedule of Rates are indicative and not exhaustive in nature. Payment shall be made as per actual quantity used/certified at site by Owner's Engineer-in-charge. Quantities indicated in Schedule of Rates are approximate and subject to variation on either side. The quantity of individual item may be deleted. Contractor shall not be entitled for any compensation on this account and the quoted rates shall hold good for such quantity variations etc. Payments on bills shall, however, be made on actual measurements of quantities of work done as per approved drawings. **Goods & Services Tax (GST) is applicable @ 18% on the quoted rates (being Works Contract).**

Name of the Bidder/ Bidding Firm / Company :	
--	--

**SCHEDULE OF RATES** (This BOQ template must not be modified/replaced by the bidder and the same should be uploaded after filling the relevent columns, else the bidder is liable to be rejected for this tender. Bidders are allowed to enter the Bidder Name and Values only )

NUMBER	TEXT #	NUMBER #	TEXT #	NUMBER #	NUMBER	NUMBER #	NUMBER #	TEXT #
Sl. No.	Item Description	Quantity	Units	BASIC RATE In Figures To be entered by the Bidder in Rs. P	GST @ 18% in RS. P	TOTAL AMOUNT Incl. All taxes & duties (Excl. GST) in Rs. P	TOTAL AMOUNT Incl. All taxes , duties and GST in Rs. P	TOTAL AMOUNT Incl. All taxes, duties and GST In Words
1.05	Supply of 12 C x 2.5 mm2 (Cu) , 1.1 KV Grade,Cable, XLPE Insulated, PVC inner Sheath, Armoured, FRLS PVC outer sheathed cables as specified in Technical Specification .	125.000	Mtrs		0.00	0.00	0.00	INR Zero Only
<b>2.0</b>	<b>ELECTRICAL SERVICE (PART-II)</b>							
<b>3.0</b>	<b>Transformer</b>							
3.01	Installation, Testing and Commissioning of 11kV/0.433kV, 250 KVA, ONAN Distribution Transformer and its accessories excluding power and control cable termination but including transportation of transformer and its accessories from owner's stores, dressing of foundation, placing in position on MS base channel/flat, assembly of all accessories supplied loose, topping up with tested oil, all labour and material complete as per drawings/specification and direction of the transformer manufacturer.	1.000	No.		0.00	0.00	0.00	INR Zero Only

Validate

Print

Help

### Item Rate BoQ

Tender Inviting Authority: Projects & Development India Limited, Noida

Name of Work: Electrical Works (Supply & Erection) Tender For Alternate Power Supply Arrangement of Vikrampur Guest House At Talcher Fertilizer Complex - Angul

Contract No: PNP/PC 183/E/8001/NCB

**NOTE :** Quantities mentioned in the Schedule of Rates are indicative and not exhaustive in nature. Payment shall be made as per actual quantity used/certified at site by Owner's Engineer-in-charge. Quantities indicated in Schedule of Rates are approximate and subject to variation on either side. The quantity of individual item may be deleted. Contractor shall not be entitled for any compensation on this account and the quoted rates shall hold good for such quantity variations etc. Payments on bills shall, however, be made on actual measurements of quantities of work done as per approved drawings. **Goods & Services Tax (GST) is applicable @ 18% on the quoted rates (being Works Contract).**

<b>Name of the Bidder/ Bidding Firm / Company :</b>	
---	--

**SCHEDULE OF RATES** (This BOQ template must not be modified/replaced by the bidder and the same should be uploaded after filling the relevent columns, else the bidder is liable to be rejected for this tender. Bidders are allowed to enter the Bidder Name and Values only )

NUMBER	TEXT #	NUMBER #	TEXT #	NUMBER #	NUMBER	NUMBER #	NUMBER #	TEXT #
Sl. No.	Item Description	Quantity	Units	BASIC RATE In Figures To be entered by the Bidder in Rs. P	GST @ 18% in RS. P	TOTAL AMOUNT Incl. All taxes & duties (Excl. GST) in Rs. P	TOTAL AMOUNT Incl. All taxes , duties and GST in Rs. P	TOTAL AMOUNT Incl. All taxes, duties and GST In Words
3.02	Supply, Filtration and Dehydration of oil/winding of transformer with streamline filter machine (to be arranged by the Contactor) for bringing the dielectric strength of the oil to the required level as per IS, complete with all labour and material including transportation oil drums from stores.	400.000	Litres		0.00	0.00	0.00	INR Zero Only
4.0	Cables (HT)							

Validate

Print

Help

### Item Rate BoQ

Tender Inviting Authority: Projects & Development India Limited, Noida

Name of Work: Electrical Works (Supply & Erection) Tender For Alternate Power Supply Arrangement of Vikrampur Guest House At Talcher Fertilizer Complex - Angul

Contract No: PNP/PC 183/E/8001/NCB

**NOTE :** Quantities mentioned in the Schedule of Rates are indicative and not exhaustive in nature. Payment shall be made as per actual quantity used/certified at site by Owner's Engineer-in-charge. Quantities indicated in Schedule of Rates are approximate and subject to variation on either side. The quantity of individual item may be deleted. Contractor shall not be entitled for any compensation on this account and the quoted rates shall hold good for such quantity variations etc. Payments on bills shall, however, be made on actual measurements of quantities of work done as per approved drawings. **Goods & Services Tax (GST) is applicable @ 18% on the quoted rates (being Works Contract).**

<b>Name of the Bidder/ Bidding Firm / Company :</b>	
---	--

**SCHEDULE OF RATES** (This BOQ template must not be modified/replaced by the bidder and the same should be uploaded after filling the relevent columns, else the bidder is liable to be rejected for this tender. Bidders are allowed to enter the Bidder Name and Values only )

NUMBER	TEXT #	NUMBER #	TEXT #	NUMBER #	NUMBER	NUMBER #	NUMBER #	TEXT #
Sl. No.	Item Description	Quantity	Units	BASIC RATE In Figures To be entered by the Bidder in Rs. P	GST @ 18% in RS. P	TOTAL AMOUNT Incl. All taxes & duties (Excl. GST) in Rs. P	TOTAL AMOUNT Incl. All taxes , duties and GST in Rs. P	TOTAL AMOUNT Incl. All taxes, duties and GST In Words
4.01	Laying (horizontal & vertical), testing and commissioning of 11 KV Grade, XLPE Insulated, PVC inner sheathed, armoured, FRLS PVC outer sheathed cables including its termination in new & readymade trenches, on pre-fabricated/ site-fabricated cable trays/ racks, on already installed risers, support, hangers, saddles / directly buried up to 1000mm depth etc. pulling through pipes on walls/columns, steel structures including transportation of cable drums from storage yard to site, unrolling the drum, including supply & fixing of cable tags, Al clamps with all labour, consumable materials and necessary hardware to make installation complete in all respect as per direction of engineer-in-charge. : 3 x 240 mm2 (Al)	2250.000	Mtrs		0.00	0.00	0.00	INR Zero Only

[Validate](#)[Print](#)[Help](#)

## Item Rate BoQ

Tender Inviting Authority: Projects &amp; Development India Limited, Noida

Name of Work: Electrical Works (Supply &amp; Erection) Tender For Alternate Power Supply Arrangement of Vikrampur Guest House At Talcher Fertilizer Complex - Angul

Contract No: PNP/PC 183/E/8001/NCB

**NOTE :** Quantities mentioned in the Schedule of Rates are indicative and not exhaustive in nature. Payment shall be made as per actual quantity used/certified at site by Owner's Engineer-in-charge. Quantities indicated in Schedule of Rates are approximate and subject to variation on either side. The quantity of individual item may be deleted. Contractor shall not be entitled for any compensation on this account and the quoted rates shall hold good for such quantity variations etc. Payments on bills shall, however, be made on actual measurements of quantities of work done as per approved drawings. **Goods & Services Tax (GST) is applicable @ 18% on the quoted rates (being Works Contract).**

<b>Name of the Bidder/ Bidding Firm / Company :</b>								
<b>SCHEDULE OF RATES</b> (This BOQ template must not be modified/replaced by the bidder and the same should be uploaded after filling the relevent columns, else the bidder is liable to be rejected for this tender. Bidders are allowed to enter the Bidder Name and Values only )								
NUMBER	TEXT #	NUMBER #	TEXT #	NUMBER #	NUMBER	NUMBER #	NUMBER #	TEXT #
Sl. No.	Item Description	Quantity	Units	BASIC RATE In Figures To be entered by the Bidder in Rs. P	GST @ 18% in RS. P	TOTAL AMOUNT Incl. All taxes & duties (Excl. GST) in Rs. P	TOTAL AMOUNT Incl. All taxes , duties and GST in Rs. P	TOTAL AMOUNT Incl. All taxes, duties and GST In Words
4.02	Supply & fixing of Heat Shrinkable Raychem make End termination Kit and subsequent testing of 11KV(UE) Grade, XLPE Insulated, PVC inner sheathed, Armoured, FRLS PVC outer sheathed cables, including supply of termination kit, glands & lugs & glanding , all labour and consumable materials to make installation complete in all respect. The rate shall include drilling, taping of cable insulation, crimping of lugs to the conductor, connection of the lugs to equipment terminal, supply and fixing of G.I. nuts, screws, bolts, washers and other necessary hardware, PVC tape of required grade for taping, making cable entries dust and vermin proof, earthing etc. as per instruction of manufacturer, approved drawings, specifications and directions of engineer-in-charge. : 3C x 240 sq. mm (AI)	2.000	Nos.		0.00	0.00	0.00	INR Zero Only

[Validate](#)[Print](#)[Help](#)

## Item Rate BoQ

Tender Inviting Authority: Projects &amp; Development India Limited, Noida

Name of Work: Electrical Works (Supply &amp; Erection) Tender For Alternate Power Supply Arrangement of Vikrampur Guest House At Talcher Fertilizer Complex - Angul

Contract No: PNPM/PC 183/E/8001/NCB

**NOTE : Quantities mentioned in the Schedule of Rates are indicative and not exhaustive in nature. Payment shall be made as per actual quantity used/certified at site by Owner's Engineer-in-charge. Quantities indicated in Schedule of Rates are approximate and subject to variation on either side. The quantity of individual item may be deleted. Contractor shall not be entitled for any compensation on this account and the quoted rates shall hold good for such quantity variations etc. Payments on bills shall, however, be made on actual measurements of quantities of work done as per approved drawings. Goods & Services Tax (GST) is applicable @ 18% on the quoted rates (being Works Contract).**

Name of the Bidder/ Bidding Firm / Company :	
--	--

**SCHEDULE OF RATES** (This BOQ template must not be modified/replaced by the bidder and the same should be uploaded after filling the relevent columns, else the bidder is liable to be rejected for this tender. Bidders are allowed to enter the Bidder Name and Values only )

NUMBER	TEXT #	NUMBER #	TEXT #	NUMBER #	NUMBER	NUMBER #	NUMBER #	TEXT #
Sl. No.	Item Description	Quantity	Units	BASIC RATE In Figures To be entered by the Bidder in Rs. P	GST @ 18% in RS. P	TOTAL AMOUNT Incl. All taxes & duties (Excl. GST) in Rs. P	TOTAL AMOUNT Incl. All taxes , duties and GST in Rs. P	TOTAL AMOUNT Incl. All taxes, duties and GST In Words
4.03	Supply & fixing of Heat Shrinkable Raychem make straight through jointing kit suitable for 11 KV grade (UE) XLPE-A-FRLSPVC insulated armoured cables of following sizes including cutting, stripping of cable insulation complete with supply of compression / crimping type ferrules, plastic mould and epoxy resin compound etc., including all labour and materials, as per approved drawings, specifications and directions of Engineer-in-Charge. : 3C x 240 sq. mm (AI, 11 KV)	4.000	No.		0.00	0.00	0.00	INR Zero Only
5.0	Cables (LT)							

Validate

Print

Help

### Item Rate BoQ

Tender Inviting Authority: Projects & Development India Limited, Noida

Name of Work: Electrical Works (Supply & Erection) Tender For Alternate Power Supply Arrangement of Vikrampur Guest House At Talcher Fertilizer Complex - Angul

Contract No: PNP/PC 183/E/8001/NCB

**NOTE :** Quantities mentioned in the Schedule of Rates are indicative and not exhaustive in nature. Payment shall be made as per actual quantity used/certified at site by Owner's Engineer-in-charge. Quantities indicated in Schedule of Rates are approximate and subject to variation on either side. The quantity of individual item may be deleted. Contractor shall not be entitled for any compensation on this account and the quoted rates shall hold good for such quantity variations etc. Payments on bills shall, however, be made on actual measurements of quantities of work done as per approved drawings. **Goods & Services Tax (GST) is applicable @ 18% on the quoted rates (being Works Contract).**

<b>Name of the Bidder/ Bidding Firm / Company :</b>	
---	--

**SCHEDULE OF RATES** (This BOQ template must not be modified/replaced by the bidder and the same should be uploaded after filling the relevent columns, else the bidder is liable to be rejected for this tender. Bidders are allowed to enter the Bidder Name and Values only )

NUMBER	TEXT #	NUMBER #	TEXT #	NUMBER #	NUMBER	NUMBER #	NUMBER #	TEXT #
Sl. No.	Item Description	Quantity	Units	BASIC RATE In Figures To be entered by the Bidder in Rs. P	GST @ 18% in RS. P	TOTAL AMOUNT Incl. All taxes & duties (Excl. GST) in Rs. P	TOTAL AMOUNT Incl. All taxes , duties and GST in Rs. P	TOTAL AMOUNT Incl. All taxes, duties and GST In Words
5.01	Horizontal and vertical laying, testing (before and after laying) and commissioning of following LV Power & Control cables in readymade trenches, on pre-fabricated cable trays / racks, on already installed risers, support hangers, saddles / directly buried up to 1000mm depth etc.etc. pulling through pipes on walls / columns, steel structures including transportation of cable drums from storage yard to the site, unrolling the drum, laying the required length of cables including supply and fixing of necessary saddles, saddle bars, cable tags, AI clamps for cables laid vertical on walls / columns / structures, risers with all labour, consumable materials and necessary hardware to make installation complete in all respect as per approved standard drawings and direction of engineer-in-charge. : 3.5 x 300 mm2 (AI)	250.000	Mtrs		0.00	0.00	0.00	INR Zero Only

Validate

Print

Help

### Item Rate BoQ

Tender Inviting Authority: Projects & Development India Limited, Noida

Name of Work: Electrical Works (Supply & Erection) Tender For Alternate Power Supply Arrangement of Vikrampur Guest House At Talcher Fertilizer Complex - Angul

Contract No: PNP/PC 183/E/8001/NCB

**NOTE :** Quantities mentioned in the Schedule of Rates are indicative and not exhaustive in nature. Payment shall be made as per actual quantity used/certified at site by Owner's Engineer-in-charge. Quantities indicated in Schedule of Rates are approximate and subject to variation on either side. The quantity of individual item may be deleted. Contractor shall not be entitled for any compensation on this account and the quoted rates shall hold good for such quantity variations etc. Payments on bills shall, however, be made on actual measurements of quantities of work done as per approved drawings. **Goods & Services Tax (GST) is applicable @ 18% on the quoted rates (being Works Contract).**

<b>Name of the Bidder/ Bidding Firm / Company :</b>	
---	--

**SCHEDULE OF RATES** (This BOQ template must not be modified/replaced by the bidder and the same should be uploaded after filling the relevent columns, else the bidder is liable to be rejected for this tender. Bidders are allowed to enter the Bidder Name and Values only )

NUMBER	TEXT #	NUMBER #	TEXT #	NUMBER #	NUMBER	NUMBER #	NUMBER #	TEXT #
Sl. No.	Item Description	Quantity	Units	BASIC RATE In Figures To be entered by the Bidder in Rs. P	GST @ 18% in RS. P	TOTAL AMOUNT Incl. All taxes & duties (Excl. GST) in Rs. P	TOTAL AMOUNT Incl. All taxes , duties and GST in Rs. P	TOTAL AMOUNT Incl. All taxes, duties and GST In Words
5.02	Horizontal and vertical laying, testing (before and after laying) and commissioning of following LV Power & Control cables in readymade trenches, on pre-fabricated cable trays / racks, on already installed risers, support hangers, saddles / directly buried up to 1000mm depth etc.etc. pulling through pipes on walls / columns, steel structures including transportation of cable drums from storage yard to the site, unrolling the drum, laying the required length of cables including supply and fixing of necessary saddles, saddle bars, cable tags, AI clamps for cables laid vertical on walls / columns / structures, risers with all labour, consumable materials and necessary hardware to make installation complete in all respect as per approved standard drawings and direction of engineer-in-charge. <b>:3 C x 2.5 mm2 (Cu)</b>	250.000	Mtrs		0.00	0.00	0.00	INR Zero Only



[Validate](#)[Print](#)[Help](#)

## Item Rate BoQ

Tender Inviting Authority: Projects &amp; Development India Limited, Noida

Name of Work: Electrical Works (Supply &amp; Erection) Tender For Alternate Power Supply Arrangement of Vikrampur Guest House At Talcher Fertilizer Complex - Angul

Contract No: PNP/PC 183/E/8001/NCB

**NOTE :** Quantities mentioned in the Schedule of Rates are indicative and not exhaustive in nature. Payment shall be made as per actual quantity used/certified at site by Owner's Engineer-in-charge. Quantities indicated in Schedule of Rates are approximate and subject to variation on either side. The quantity of individual item may be deleted. Contractor shall not be entitled for any compensation on this account and the quoted rates shall hold good for such quantity variations etc. Payments on bills shall, however, be made on actual measurements of quantities of work done as per approved drawings. **Goods & Services Tax (GST) is applicable @ 18% on the quoted rates (being Works Contract).**

<b>Name of the Bidder/ Bidding Firm / Company :</b>								
<b>SCHEDULE OF RATES</b> (This BOQ template must not be modified/replaced by the bidder and the same should be uploaded after filling the relevent columns, else the bidder is liable to be rejected for this tender. Bidders are allowed to enter the Bidder Name and Values only )								
NUMBER	TEXT #	NUMBER #	TEXT #	NUMBER #	NUMBER	NUMBER #	NUMBER #	TEXT #
Sl. No.	Item Description	Quantity	Units	BASIC RATE In Figures To be entered by the Bidder in Rs. P	GST @ 18% in RS. P	TOTAL AMOUNT Incl. All taxes & duties (Excl. GST) in Rs. P	TOTAL AMOUNT Incl. All taxes , duties and GST in Rs. P	TOTAL AMOUNT Incl. All taxes, duties and GST In Words
5.03	Horizontal and vertical laying, testing (before and after laying) and commissioning of following LV Power & Control cables in readymade trenches, on pre-fabricated cable trays / racks, on already installed risers, support hangers, saddles / directly buried up to 1000mm depth etc.etc. pulling through pipes on walls / columns, steel structures including transportation of cable drums from storage yard to the site, unrolling the drum, laying the required length of cables including supply and fixing of necessary saddles, saddle bars, cable tags, Al clamps for cables laid vertical on walls / columns / structures, risers with all labour, consumable materials and necessary hardware to make installation complete in all respect as per approved standard drawings and direction of engineer-in-charge. : 12 C x 2.5 mm2 (Cu)	125.000	Mtr		0.00	0.00	0.00	INR Zero Only
6.0	<b>Cable Glands</b>							

[Validate](#)[Print](#)[Help](#)

## Item Rate BoQ

Tender Inviting Authority: Projects &amp; Development India Limited, Noida

Name of Work: Electrical Works (Supply &amp; Erection) Tender For Alternate Power Supply Arrangement of Vikrampur Guest House At Talcher Fertilizer Complex - Angul

Contract No: PNPM/PC 183/E/8001/NCB

**NOTE :** Quantities mentioned in the Schedule of Rates are indicative and not exhaustive in nature. Payment shall be made as per actual quantity used/certified at site by Owner's Engineer-in-charge. Quantities indicated in Schedule of Rates are approximate and subject to variation on either side. The quantity of individual item may be deleted. Contractor shall not be entitled for any compensation on this account and the quoted rates shall hold good for such quantity variations etc. Payments on bills shall, however, be made on actual measurements of quantities of work done as per approved drawings. **Goods & Services Tax (GST) is applicable @ 18% on the quoted rates (being Works Contract).**

Name of the Bidder/ Bidding Firm / Company :	
--	--

**SCHEDULE OF RATES** (This BOQ template must not be modified/replaced by the bidder and the same should be uploaded after filling the relevent columns, else the bidder is liable to be rejected for this tender. Bidders are allowed to enter the Bidder Name and Values only )

NUMBER	TEXT #	NUMBER #	TEXT #	NUMBER #	NUMBER	NUMBER #	NUMBER #	TEXT #
Sl. No.	Item Description	Quantity	Units	BASIC RATE In Figures To be entered by the Bidder in Rs. P	GST @ 18% in RS. P	TOTAL AMOUNT Incl. All taxes & duties (Excl. GST) in Rs. P	TOTAL AMOUNT Incl. All taxes , duties and GST in Rs. P	TOTAL AMOUNT Incl. All taxes, duties and GST In Words
6.01	1.1 KV Grade, XLPE Insulated, PVC inner Sheath, FRLS PVC outer sheathed cables. :3.5 x 300 mm2 (Al)	4.000	Nos.		0.00	0.00	0.00	INR Zero Only
6.02	1.1 KV Grade, XLPE Insulated, PVC inner Sheath, FRLS PVC outer sheathed cables. :3 C x 2.5 mm2 (Cu)	6.000	Nos.		0.00	0.00	0.00	INR Zero Only
6.03	1.1 KV Grade, XLPE Insulated, PVC inner Sheath, FRLS PVC outer sheathed cables. :12 C x 2.5 mm2 (Cu)	2.000	Nos.		0.00	0.00	0.00	INR Zero Only

Validate

Print

Help

### Item Rate BoQ

Tender Inviting Authority: Projects & Development India Limited, Noida

Name of Work: Electrical Works (Supply & Erection) Tender For Alternate Power Supply Arrangement of Vikrampur Guest House At Talcher Fertilizer Complex - Angul

Contract No: PNP/PC 183/E/8001/NCB

**NOTE :** Quantities mentioned in the Schedule of Rates are indicative and not exhaustive in nature. Payment shall be made as per actual quantity used/certified at site by Owner's Engineer-in-charge. Quantities indicated in Schedule of Rates are approximate and subject to variation on either side. The quantity of individual item may be deleted. Contractor shall not be entitled for any compensation on this account and the quoted rates shall hold good for such quantity variations etc. Payments on bills shall, however, be made on actual measurements of quantities of work done as per approved drawings. **Goods & Services Tax (GST) is applicable @ 18% on the quoted rates (being Works Contract)**

<b>Name of the Bidder/ Bidding Firm / Company :</b>	
---	--

**SCHEDULE OF RATES** (This BOQ template must not be modified/replaced by the bidder and the same should be uploaded after filling the relevent columns, else the bidder is liable to be rejected for this tender. Bidders are allowed to enter the Bidder Name and Values only )

NUMBER	TEXT #	NUMBER #	TEXT #	NUMBER #	NUMBER	NUMBER #	NUMBER #	TEXT #
Sl. No.	Item Description	Quantity	Units	BASIC RATE In Figures To be entered by the Bidder in Rs. P	GST @ 18% in RS. P	TOTAL AMOUNT Incl. All taxes & duties (Excl. GST) in Rs. P	TOTAL AMOUNT Incl. All taxes , duties and GST in Rs. P	TOTAL AMOUNT Incl. All taxes, duties and GST In Words
7.0	<b>Termination of Cables:</b> End termination and subsequent testing of XLPE insulated single core/ multi core armoured cables of 1.1KV grade, Al/ Cu cable., excluding supply of termination kits, glands but including lugs , all labour and consumable materials to make installation complete in all respect. Modification in existing switch board for accommodating the proposed cables. The rate shall include drilling, taping of cable insulation, crimping of lugs to the conductor, connection of the lugs to equipment terminal, supply and fixing of supports & clamps for cables, G.I. nuts, screws, bolts, washers and other necessary hardware, PVC tape of required grade for taping, making cable entries dust and vermin proof, earthing etc. as per instruction of manufacturer, approved drawings, specifications and directions of engineer-in-charge.							

[Validate](#)[Print](#)[Help](#)

## Item Rate BoQ

Tender Inviting Authority: Projects &amp; Development India Limited, Noida

Name of Work: Electrical Works (Supply &amp; Erection) Tender For Alternate Power Supply Arrangement of Vikrampur Guest House At Talcher Fertilizer Complex - Angul

Contract No: PNP/PC 183/E/8001/NCB

**NOTE :** Quantities mentioned in the Schedule of Rates are indicative and not exhaustive in nature. Payment shall be made as per actual quantity used/certified at site by Owner's Engineer-in-charge. Quantities indicated in Schedule of Rates are approximate and subject to variation on either side. The quantity of individual item may be deleted. Contractor shall not be entitled for any compensation on this account and the quoted rates shall hold good for such quantity variations etc. Payments on bills shall, however, be made on actual measurements of quantities of work done as per approved drawings. **Goods & Services Tax (GST) is applicable @ 18% on the quoted rates (being Works Contract).**

Name of the Bidder/ Bidding Firm / Company :	
--	--

**SCHEDULE OF RATES** (This BOQ template must not be modified/replaced by the bidder and the same should be uploaded after filling the relevent columns, else the bidder is liable to be rejected for this tender. Bidders are allowed to enter the Bidder Name and Values only )

NUMBER	TEXT #	NUMBER #	TEXT #	NUMBER #	NUMBER	NUMBER #	NUMBER #	TEXT #
Sl. No.	Item Description	Quantity	Units	BASIC RATE In Figures To be entered by the Bidder in Rs. P	GST @ 18% in RS. P	TOTAL AMOUNT Incl. All taxes & duties (Excl. GST) in Rs. P	TOTAL AMOUNT Incl. All taxes , duties and GST in Rs. P	TOTAL AMOUNT Incl. All taxes, duties and GST In Words
7.01	1.1 KV grade, XLPE Insulated, PVC inner sheath, armoured, FRLS PVC outer, Stranded Cu/ Al Conductor cables as per IS:7098 (Part-1) of the following sizes. : 3.5 x 300 mm2 (Al)	4.000	Nos.		0.00	0.00	0.00	INR Zero Only
7.02	1.1 KV grade, XLPE Insulated, PVC inner sheath, armoured, FRLS PVC outer, Stranded Cu/ Al Conductor cables as per IS:7098 (Part-1) of the following sizes. : 3 C x 2.5 mm2 (Cu)	6.000	Nos.		0.00	0.00	0.00	INR Zero Only
7.03	1.1 KV grade, XLPE Insulated, PVC inner sheath, armoured, FRLS PVC outer, Stranded Cu/ Al Conductor cables as per IS:7098 (Part-1) of the following sizes. : 12 C x 2.5 mm2 (Cu)	6.000	Nos.		0.00	0.00	0.00	INR Zero Only
8.0	Earthing							

Validate

Print

Help

### Item Rate BoQ

Tender Inviting Authority: Projects & Development India Limited, Noida

Name of Work: Electrical Works (Supply & Erection) Tender For Alternate Power Supply Arrangement of Vikrampur Guest House At Talcher Fertilizer Complex - Angul

Contract No: PNP/PC 183/E/8001/NCB

**NOTE : Quantities mentioned in the Schedule of Rates are indicative and not exhaustive in nature. Payment shall be made as per actual quantity used/certified at site by Owner's Engineer-in-charge. Quantities indicated in Schedule of Rates are approximate and subject to variation on either side. The quantity of individual item may be deleted. Contractor shall not be entitled for any compensation on this account and the quoted rates shall hold good for such quantity variations etc. Payments on bills shall, however, be made on actual measurements of quantities of work done as per approved drawings. Goods & Services Tax (GST) is applicable @ 18% on the quoted rates (being Works Contract).**

<b>Name of the Bidder/ Bidding Firm / Company :</b>	
---	--

**SCHEDULE OF RATES** (This BOQ template must not be modified/replaced by the bidder and the same should be uploaded after filling the relevent columns, else the bidder is liable to be rejected for this tender. Bidders are allowed to enter the Bidder Name and Values only )

NUMBER	TEXT #	NUMBER #	TEXT #	NUMBER #	NUMBER	NUMBER #	NUMBER #	TEXT #
Sl. No.	Item Description	Quantity	Units	BASIC RATE In Figures To be entered by the Bidder in Rs. P	GST @ 18% in RS. P	TOTAL AMOUNT Incl. All taxes & duties (Excl. GST) in Rs. P	TOTAL AMOUNT Incl. All taxes , duties and GST in Rs. P	TOTAL AMOUNT Incl. All taxes, duties and GST In Words
8.01	Supply, Installation, Testing & Commissioning of 100 NB,3.8 M. Long G.I.pipe Earth Electrode in Earth pit including Earth Bus as per PDS attached with TS Including handling, transportation to Erection site, Excavation of Earth pit in all types of soil, back filling of pit with common salt, charcoal / coke and loose Earth after installation of Electrode there in, removal of surplus Earth away from Erection site, consolidation of loose Earth on back filled pit, making of bricks work, Inspection chamber on back filled pit and cover of RCC ,there of complete with lifting hook, fixing & connecting inside the chamber of G.I. Earth bracket and other accessories of the Earth Electrode, painting of Earth pit No. and Earthing symbol on the cover, supply of salt, charcoal /coke, bricks, sand, cement, stone chips, reinforcement rods, lifting hook, necessary stainless steel hardware, paints etc. all works, labour & materials complete as per Drawings, specifications, code & standards and direction of consultant/owner.	4.000	Nos.		0.00	0.00	0.00	INR Zero Only

Validate

Print

Help

### Item Rate BoQ

Tender Inviting Authority: Projects & Development India Limited, Noida

Name of Work: Electrical Works (Supply & Erection) Tender For Alternate Power Supply Arrangement of Vikrampur Guest House At Talcher Fertilizer Complex - Angul

Contract No: PNP/PC 183/E/8001/NCB

**NOTE : Quantities mentioned in the Schedule of Rates are indicative and not exhaustive in nature. Payment shall be made as per actual quantity used/certified at site by Owner's Engineer-in-charge. Quantities indicated in Schedule of Rates are approximate and subject to variation on either side. The quantity of individual item may be deleted. Contractor shall not be entitled for any compensation on this account and the quoted rates shall hold good for such quantity variations etc. Payments on bills shall, however, be made on actual measurements of quantities of work done as per approved drawings. Goods & Services Tax (GST) is applicable @ 18% on the quoted rates (being Works Contract).**

<b>Name of the Bidder/ Bidding Firm / Company :</b>	
---	--

**SCHEDULE OF RATES (This BOQ template must not be modified/replaced by the bidder and the same should be uploaded after filling the relevent columns, else the bidder is liable to be rejected for this tender. Bidders are allowed to enter the Bidder Name and Values only )**

NUMBER	TEXT #	NUMBER #	TEXT #	NUMBER #	NUMBER	NUMBER #	NUMBER #	TEXT #
Sl. No.	Item Description	Quantity	Units	BASIC RATE In Figures To be entered by the Bidder in Rs. P	GST @ 18% in RS. P	TOTAL AMOUNT Incl. All taxes & duties (Excl. GST) in Rs. P	TOTAL AMOUNT Incl. All taxes , duties and GST in Rs. P	TOTAL AMOUNT Incl. All taxes, duties and GST In Words
8.02	Supply Installation, Testing & Commissioning of GI earth strip / Wire conductors of following sizes as per PDS attached with TS enclosed in ready made concrete trenches or in floor slits, on brick / concrete wall under concrete floors, or paved areas, across pipe joints and valves, directly buried under ground at depth of 500 mm, including handling, transportation to erection site, bending, straightening, cutting to size, welding together of earth strips in overlapping manner, chipping in concrete floors/ paved areas for laying the earth strips under floors/ paved areas and making good by cement plastering concrete after laying of the strips ; clamping and supporting of earth strips laid above ground, connecting the strips/ wire at both ends to equipment or to earth bus / earth plates or to GI brackets fixed inside earth pit chamber, by bolting etc., Hessian tapes, all necessary GI hardware, GI clamps, civil masonry materials, etc. all work, labour as per specifications, codes and standards and directions of owner/consultant. of Hot Dip Galvanized GI earth strips & GI earth wire (with min. coating 610gm/sq.m) of following sizes: - <b>50 mm x 6 mm</b> <b>Note: The conductors shall be laid at a minimum depth of 500 mm from ground level. The excavation for the GI earth conductors/ strips shall not be separately measured and the rates quoted to include the same.</b>	50.000	Mtrs		0.00	0.00	0.00	INR Zero Only

Validate

Print

Help

### Item Rate BoQ

Tender Inviting Authority: Projects & Development India Limited, Noida

Name of Work: Electrical Works (Supply & Erection) Tender For Alternate Power Supply Arrangement of Vikrampur Guest House At Talcher Fertilizer Complex - Angul

Contract No: PNPM/PC 183/E/8001/NCB

**NOTE : Quantities mentioned in the Schedule of Rates are indicative and not exhaustive in nature. Payment shall be made as per actual quantity used/certified at site by Owner's Engineer-in-charge. Quantities indicated in Schedule of Rates are approximate and subject to variation on either side. The quantity of individual item may be deleted. Contractor shall not be entitled for any compensation on this account and the quoted rates shall hold good for such quantity variations etc. Payments on bills shall, however, be made on actual measurements of quantities of work done as per approved drawings. Goods & Services Tax (GST) is applicable @ 18% on the quoted rates (being Works Contract)**

<b>Name of the Bidder/ Bidding Firm / Company :</b>	
---	--

**SCHEDULE OF RATES** (This BOQ template must not be modified/replaced by the bidder and the same should be uploaded after filling the relevent columns, else the bidder is liable to be rejected for this tender. Bidders are allowed to enter the Bidder Name and Values only )

NUMBER	TEXT #	NUMBER #	TEXT #	NUMBER #	NUMBER	NUMBER #	NUMBER #	TEXT #
Sl. No.	Item Description	Quantity	Units	BASIC RATE In Figures To be entered by the Bidder in Rs. P	GST @ 18% in RS. P	TOTAL AMOUNT Incl. All taxes & duties (Excl. GST) in Rs. P	TOTAL AMOUNT Incl. All taxes , duties and GST in Rs. P	TOTAL AMOUNT Incl. All taxes, duties and GST In Words
<b>9.0</b>	<b>Cable Route Marker / Hume/GI Pipe</b>							
9.01	Supply, Grouting and Installation of Cable Route Marker of Round shape made of MS of dia. 200mm with suitable engraving as of HT/ LT / Control / Data Cable jointed with angle of 30X30X5 mm grouted in concrete of size 150mm x 150mm x 500mm.	20.000	Nos.		0.00	0.00	0.00	INR Zero Only
9.02	Supply laying of NP2 class 150 mm dia Hume pipe including collars, jointing with stiff mixture of cement mortar in proportion 1:2 including cutting of pipes wherever required	30.000	Mtrs.		0.00	0.00	0.00	INR Zero Only
9.03	Supply , Laying, installation of medium class GI pipe as per IS:1239 (part-1) of following sizes : <b>50 mm NB</b>	20.000	Mtrs.		0.00	0.00	0.00	INR Zero Only



Validate

Print

Help

### Item Rate BoQ

Tender Inviting Authority: Projects & Development India Limited, Noida

Name of Work: Electrical Works (Supply & Erection) Tender For Alternate Power Supply Arrangement of Vikrampur Guest House At Talcher Fertilizer Complex - Angul

Contract No: PNP/PC 183/E/8001/NCB

**NOTE :** Quantities mentioned in the Schedule of Rates are indicative and not exhaustive in nature. Payment shall be made as per actual quantity used/certified at site by Owner's Engineer-in-charge. Quantities indicated in Schedule of Rates are approximate and subject to variation on either side. The quantity of individual item may be deleted. Contractor shall not be entitled for any compensation on this account and the quoted rates shall hold good for such quantity variations etc. Payments on bills shall, however, be made on actual measurements of quantities of work done as per approved drawings. **Goods & Services Tax (GST) is applicable @ 18% on the quoted rates (being Works Contract).**

<b>Name of the Bidder/ Bidding Firm / Company :</b>	
---	--

**SCHEDULE OF RATES** (This BOQ template must not be modified/replaced by the bidder and the same should be uploaded after filling the relevent columns, else the bidder is liable to be rejected for this tender. Bidders are allowed to enter the Bidder Name and Values only )

NUMBER	TEXT #	NUMBER #	TEXT #	NUMBER #	NUMBER	NUMBER #	NUMBER #	TEXT #
Sl. No.	Item Description	Quantity	Units	BASIC RATE In Figures To be entered by the Bidder in Rs. P	GST @ 18% in RS. P	TOTAL AMOUNT Incl. All taxes & duties (Excl. GST) in Rs. P	TOTAL AMOUNT Incl. All taxes , duties and GST in Rs. P	TOTAL AMOUNT Incl. All taxes, duties and GST In Words
9.04	Supply , Laying, installation of medium class GI pipe as per IS:1239 (part-1) of following sizes. :100 mm NB	20.000	Mtrs.		0.00	0.00	0.00	INR Zero Only
<b>10.0</b>	<b>Excavation and Back Filling</b>							
10.01	Excavation and back filling of trenches for cables and earth strips etc. following types of soil except rocks for a maximum depth of 1.25 m for cables / 0.6 mtr. for earth strips including shoring, strutting, dewatering, consolidation and disposal of surplus earth upto100 m leads including all labour and materials to complete installation in all respect. <b>Soft soil</b>	500.000	CuM		0.00	0.00	0.00	INR Zero Only

Validate

Print

Help

### Item Rate BoQ

Tender Inviting Authority: Projects & Development India Limited, Noida

Name of Work: Electrical Works (Supply & Erection) Tender For Alternate Power Supply Arrangement of Vikrampur Guest House At Talcher Fertilizer Complex - Angul

Contract No: PNPM/PC 183/E/8001/NCB

**NOTE : Quantities mentioned in the Schedule of Rates are indicative and not exhaustive in nature. Payment shall be made as per actual quantity used/certified at site by Owner's Engineer-in-charge. Quantities indicated in Schedule of Rates are approximate and subject to variation on either side. The quantity of individual item may be deleted. Contractor shall not be entitled for any compensation on this account and the quoted rates shall hold good for such quantity variations etc. Payments on bills shall, however, be made on actual measurements of quantities of work done as per approved drawings. Goods & Services Tax (GST) is applicable @ 18% on the quoted rates (being Works Contract).**

<b>Name of the Bidder/ Bidding Firm / Company :</b>	
---	--

**SCHEDULE OF RATES** (This BOQ template must not be modified/replaced by the bidder and the same should be uploaded after filling the relevent columns, else the bidder is liable to be rejected for this tender. Bidders are allowed to enter the Bidder Name and Values only )

NUMBER	TEXT #	NUMBER #	TEXT #	NUMBER #	NUMBER	NUMBER #	NUMBER #	TEXT #
Sl. No.	Item Description	Quantity	Units	BASIC RATE In Figures To be entered by the Bidder in Rs. P	GST @ 18% in RS. P	TOTAL AMOUNT Incl. All taxes & duties (Excl. GST) in Rs. P	TOTAL AMOUNT Incl. All taxes , duties and GST in Rs. P	TOTAL AMOUNT Incl. All taxes, duties and GST In Words
10.02	Excavation and back filling of trenches for cables and earth strips etc. following types of soil except rocks for a maximum depth of 1.25 m for cables / 0.6 mtr. for earth strips including shoring, strutting, dewatering, consolidation and disposal of surplus earth upto100 m leads including all labour and materials to complete installation in all respect. <b>Back filling with excavated earth in trench including consolidating each deposited layer by ramming, dressing etc.</b>	425.000	CuM		0.00	0.00	0.00	INR Zero Only
<b>11.0</b>	<b>Fine River Sand For Cable Trench</b>							
11.01	Supply & Spreading of approved fine river sand in cable trenches up to a depth of 250 mm (100 mm below the centre line of cable and 150 mm above cable the centre line of cable) including all labour and materials to make the installation complete in all respect as per approved drawings, specifications and directions of engineer-in-charge.	35.000	CuM		0.00	0.00	0.00	INR Zero Only

Validate

Print

Help

### Item Rate BoQ

Tender Inviting Authority: Projects & Development India Limited, Noida

Name of Work: Electrical Works (Supply & Erection) Tender For Alternate Power Supply Arrangement of Vikrampur Guest House At Talcher Fertilizer Complex - Angul

Contract No: PNP/PC 183/E/8001/NCB

**NOTE :** Quantities mentioned in the Schedule of Rates are indicative and not exhaustive in nature. Payment shall be made as per actual quantity used/certified at site by Owner's Engineer-in-charge. Quantities indicated in Schedule of Rates are approximate and subject to variation on either side. The quantity of individual item may be deleted. Contractor shall not be entitled for any compensation on this account and the quoted rates shall hold good for such quantity variations etc. Payments on bills shall, however, be made on actual measurements of quantities of work done as per approved drawings. **Goods & Services Tax (GST) is applicable @ 18% on the quoted rates (being Works Contract).**

<b>Name of the Bidder/ Bidding Firm / Company :</b>	
---	--

**SCHEDULE OF RATES** (This BOQ template must not be modified/replaced by the bidder and the same should be uploaded after filling the relevent columns, else the bidder is liable to be rejected for this tender. Bidders are allowed to enter the Bidder Name and Values only )

NUMBER	TEXT #	NUMBER #	TEXT #	NUMBER #	NUMBER	NUMBER #	NUMBER #	TEXT #
Sl. No.	Item Description	Quantity	Units	BASIC RATE In Figures To be entered by the Bidder in Rs. P	GST @ 18% in RS. P	TOTAL AMOUNT Incl. All taxes & duties (Excl. GST) in Rs. P	TOTAL AMOUNT Incl. All taxes , duties and GST in Rs. P	TOTAL AMOUNT Incl. All taxes, duties and GST In Words
<b>12.0</b>	<b>Bricks For Cable Trench</b>							
12.01	Supply & Spreading of approved "B" class bricks of dimension 230mmx115mmx75mm in cable trenches for cable protection including all labour and materials to make installation complete in all respect.	28000.000	Nos.		0.00	0.00	0.00	INR Zero Only
<b>13.0</b>	<b>Structural Steel</b>							
13.01	Supply, Fabrication and installation of MS frame supports and brackets base frame, hanger, risers, clamps, etc. for different electrical equipment as and where required. The job will include cutting, drilling, welding, reverting, bolting, grouting etc steel structural with a coat of epoxy primer and two coats of epoxy paint including supply of all consumable necessary hardware, paints etc.of various size of steel structure as required at set.	0.500	Ton		0.00	0.00	0.00	INR Zero Only

[Validate](#)[Print](#)[Help](#)

## Item Rate BoQ

Tender Inviting Authority: Projects &amp; Development India Limited, Noida

Name of Work: Electrical Works (Supply &amp; Erection) Tender For Alternate Power Supply Arrangement of Vikrampur Guest House At Talcher Fertilizer Complex - Angul

Contract No: PNP/PC 183/E/8001/NCB

**NOTE :** Quantities mentioned in the Schedule of Rates are indicative and not exhaustive in nature. Payment shall be made as per actual quantity used/certified at site by Owner's Engineer-in-charge. Quantities indicated in Schedule of Rates are approximate and subject to variation on either side. The quantity of individual item may be deleted. Contractor shall not be entitled for any compensation on this account and the quoted rates shall hold good for such quantity variations etc. Payments on bills shall, however, be made on actual measurements of quantities of work done as per approved drawings. **Goods & Services Tax (GST) is applicable @ 18% on the quoted rates (being Works Contract).**

Name of the Bidder/ Bidding Firm / Company :								
<b>SCHEDULE OF RATES</b> (This BOQ template must not be modified/replaced by the bidder and the same should be uploaded after filling the relevent columns, else the bidder is liable to be rejected for this tender. Bidders are allowed to enter the Bidder Name and Values only )								
NUMBER	TEXT #	NUMBER #	TEXT #	NUMBER #	NUMBER	NUMBER #	NUMBER #	TEXT #
Sl. No.	Item Description	Quantity	Units	BASIC RATE In Figures To be entered by the Bidder in Rs. P	GST @ 18% in RS. P	TOTAL AMOUNT Incl. All taxes & duties (Excl. GST) in Rs. P	TOTAL AMOUNT Incl. All taxes , duties and GST in Rs. P	TOTAL AMOUNT Incl. All taxes, duties and GST In Words
<b>14.0</b>	<b>Safety Equipment</b>							
14.01	Vitreous enamel caution boards (HINDI/ ENGLISH/ODIYA) as per IS 2551 including fixing on the wall with all required hardware etc. complete. : <b>11 K V</b>	2.000	Nos.		0.00	0.00	0.00	INR Zero Only
14.02	Vitreous enamel caution boards (HINDI/ ENGLISH/ODIYA) as per IS 2551 including fixing on the wall with all required hardware etc. complete. : <b>440 V</b>	2.000	Nos.		0.00	0.00	0.00	INR Zero Only
14.03	4 Nos. round bottom sand buckets with handle on floor mounted stand. The buckets to be marked "FIRE" in ENGLISH/ HINDI including supply and fixing with necessary clamps, bolts and all other hardware as required.	1.000	Set		0.00	0.00	0.00	INR Zero Only

Validate

Print

Help

### Item Rate BoQ

Tender Inviting Authority: Projects & Development India Limited, Noida

Name of Work: Electrical Works (Supply & Erection) Tender For Alternate Power Supply Arrangement of Vikrampur Guest House At Talcher Fertilizer Complex - Angul

Contract No: PNP/PC 183/E/8001/NCB

**NOTE :** Quantities mentioned in the Schedule of Rates are indicative and not exhaustive in nature. Payment shall be made as per actual quantity used/certified at site by Owner's Engineer-in-charge. Quantities indicated in Schedule of Rates are approximate and subject to variation on either side. The quantity of individual item may be deleted. Contractor shall not be entitled for any compensation on this account and the quoted rates shall hold good for such quantity variations etc. Payments on bills shall, however, be made on actual measurements of quantities of work done as per approved drawings. **Goods & Services Tax (GST) is applicable @ 18% on the quoted rates (being Works Contract).**

<b>Name of the Bidder/ Bidding Firm / Company :</b>	
---	--

**SCHEDULE OF RATES** (This BOQ template must not be modified/replaced by the bidder and the same should be uploaded after filling the relevent columns, else the bidder is liable to be rejected for this tender. Bidders are allowed to enter the Bidder Name and Values only )

NUMBER	TEXT #	NUMBER #	TEXT #	NUMBER #	NUMBER	NUMBER #	NUMBER #	TEXT #
Sl. No.	Item Description	Quantity	Units	BASIC RATE In Figures To be entered by the Bidder in Rs. P	GST @ 18% in RS. P	TOTAL AMOUNT Incl. All taxes & duties (Excl. GST) in Rs. P	TOTAL AMOUNT Incl. All taxes , duties and GST in Rs. P	TOTAL AMOUNT Incl. All taxes, duties and GST In Words
15.0	Supply, Installation, Testing and Commissioning of prewired wall/ceiling/false ceiling mounted type following LED lighting fixtures including providing & fixing LED lighting fixtures, electronic drivers,condensers,internal & external reflectors, louvers, etc. Including handling, transportation from owners store to erection site, unpacking, inspection; checking of internal wiring; Erection in position on false ceiling / floor etc ,cable glanding, crimping of lugs and connections at fixtures; supply of all erection materials Including necessary GI hardware, GI clamps, GI brackets, civil masonry materials; all work, labour and materials complete as per drawings, specifications, codes and standards and directions of Engineer in charge.							

Validate

Print

Help

### Item Rate BoQ

Tender Inviting Authority: Projects & Development India Limited, Noida

Name of Work: Electrical Works (Supply & Erection) Tender For Alternate Power Supply Arrangement of Vikrampur Guest House At Talcher Fertilizer Complex - Angul

Contract No: PNP/PC 183/E/8001/NCB

**NOTE :** Quantities mentioned in the Schedule of Rates are indicative and not exhaustive in nature. Payment shall be made as per actual quantity used/certified at site by Owner's Engineer-in-charge. Quantities indicated in Schedule of Rates are approximate and subject to variation on either side. The quantity of individual item may be deleted. Contractor shall not be entitled for any compensation on this account and the quoted rates shall hold good for such quantity variations etc. Payments on bills shall, however, be made on actual measurements of quantities of work done as per approved drawings. **Goods & Services Tax (GST) is applicable @ 18% on the quoted rates (being Works Contract).**

<b>Name of the Bidder/ Bidding Firm / Company :</b>	
---	--

**SCHEDULE OF RATES** (This BOQ template must not be modified/replaced by the bidder and the same should be uploaded after filling the relevent columns, else the bidder is liable to be rejected for this tender. Bidders are allowed to enter the Bidder Name and Values only )

NUMBER	TEXT #	NUMBER #	TEXT #	NUMBER #	NUMBER	NUMBER #	NUMBER #	TEXT #
Sl. No.	Item Description	Quantity	Units	BASIC RATE In Figures To be entered by the Bidder in Rs. P	GST @ 18% in RS. P	TOTAL AMOUNT Incl. All taxes & duties (Excl. GST) in Rs. P	TOTAL AMOUNT Incl. All taxes , duties and GST in Rs. P	TOTAL AMOUNT Incl. All taxes, duties and GST In Words
15.01	240VAC 1 phase 45 W Street Lighting Fixtures. with LED lamp in weatherproof & hose proof light Min IP55, fixture complete with driver ,cable glands and other accessories, suitable for 3 X 2.5mm2 (Cu) cable and stopping plug for outdoor area.	4.000	Nos.		0.00	0.00	0.00	INR Zero Only
16.0	<b>CIVIL WORKS (PART- III)</b>							
17.0	<b>Plain Cement Concrete &amp; RCC &amp; Reinforcement</b>							
17.01	Providing and lay ing plain cement concrete, machine mixed and mechanically vibrated in foundations,plinth, under floors, etc., including all necessary cost of centring and shuttering:							

[Validate](#)[Print](#)[Help](#)

## Item Rate BoQ

Tender Inviting Authority: Projects &amp; Development India Limited, Noida

Name of Work: Electrical Works (Supply &amp; Erection) Tender For Alternate Power Supply Arrangement of Vikrampur Guest House At Talcher Fertilizer Complex - Angul

Contract No: PNP/PC 183/E/8001/NCB

**NOTE :** Quantities mentioned in the Schedule of Rates are indicative and not exhaustive in nature. Payment shall be made as per actual quantity used/certified at site by Owner's Engineer-in-charge. Quantities indicated in Schedule of Rates are approximate and subject to variation on either side. The quantity of individual item may be deleted. Contractor shall not be entitled for any compensation on this account and the quoted rates shall hold good for such quantity variations etc. Payments on bills shall, however, be made on actual measurements of quantities of work done as per approved drawings. **Goods & Services Tax (GST) is applicable @ 18% on the quoted rates (being Works Contract).**

Name of the Bidder/ Bidding Firm / Company :	
--	--

**SCHEDULE OF RATES** (This BOQ template must not be modified/replaced by the bidder and the same should be uploaded after filling the relevant columns, else the bidder is liable to be rejected for this tender. Bidders are allowed to enter the Bidder Name and Values only )

NUMBER	TEXT #	NUMBER #	TEXT #	NUMBER #	NUMBER	NUMBER #	NUMBER #	TEXT #
Sl. No.	Item Description	Quantity	Units	BASIC RATE In Figures To be entered by the Bidder in Rs. P	GST @ 18% in RS. P	TOTAL AMOUNT Incl. All taxes & duties (Excl. GST) in Rs. P	TOTAL AMOUNT Incl. All taxes , duties and GST in Rs. P	TOTAL AMOUNT Incl. All taxes, duties and GST In Words
17.02	1:5:10 (1 cement: 5 coarse sand:10 graded stone aggregate 20 mm nominal size).	2.000	CuM		0.00	0.00	0.00	INR Zero Only
17.03	1:4:8 (1 cement: 4 coarse sand:8 graded stone aggregate 20 mm nominal size).	1.000	CuM		0.00	0.00	0.00	INR Zero Only
17.04	Providing and laying in position specified grade of reinforced cement concrete, machine mixed, mechanically vibrated and finished to a fair face but including the cost of centring and shuttering excluding reinforcement in superstructure at all heights for columns, pillars, posts, attached pilasters, portals, struts, inclined posts, pedestals ,Beam, walls, Roof, Slabs etc., complete in all respects as per direction of Engineer-in-Charge. - Design mix M25 grade concrete	1.000	CuM		0.00	0.00	0.00	INR Zero Only



Validate

Print

Help

### Item Rate BoQ

Tender Inviting Authority: Projects & Development India Limited, Noida

Name of Work: Electrical Works (Supply & Erection) Tender For Alternate Power Supply Arrangement of Vikrampur Guest House At Talcher Fertilizer Complex - Angul

Contract No: PNPM/PC 183/E/8001/NCB

**NOTE : Quantities mentioned in the Schedule of Rates are indicative and not exhaustive in nature. Payment shall be made as per actual quantity used/certified at site by Owner's Engineer-in-charge. Quantities indicated in Schedule of Rates are approximate and subject to variation on either side. The quantity of individual item may be deleted. Contractor shall not be entitled for any compensation on this account and the quoted rates shall hold good for such quantity variations etc. Payments on bills shall, however, be made on actual measurements of quantities of work done as per approved drawings. Goods & Services Tax (GST) is applicable @ 18% on the quoted rates (being Works Contract).**

<b>Name of the Bidder/ Bidding Firm / Company :</b>	
---	--

**SCHEDULE OF RATES** (This BOQ template must not be modified/replaced by the bidder and the same should be uploaded after filling the relevent columns, else the bidder is liable to be rejected for this tender. Bidders are allowed to enter the Bidder Name and Values only )

NUMBER	TEXT #	NUMBER #	TEXT #	NUMBER #	NUMBER	NUMBER #	NUMBER #	TEXT #
Sl. No.	Item Description	Quantity	Units	BASIC RATE In Figures To be entered by the Bidder in Rs. P	GST @ 18% in RS. P	TOTAL AMOUNT Incl. All taxes & duties (Excl. GST) in Rs. P	TOTAL AMOUNT Incl. All taxes , duties and GST in Rs. P	TOTAL AMOUNT Incl. All taxes, duties and GST In Words
17.05	Providing and laying in position reinforced cement concrete in foundations, walls, plinth beams etc. including the cost of centring, shuttering, finishing but excluding reinforcement - All work up to plinth level - Design mix M25 grade concrete.	1.000	CuM		0.00	0.00	0.00	INR Zero Only
17.06	Supplying, providing and laying Steel reinforcement (Hot rolled deformed bars) for R.C.C. work including straightening, cutting, bending, placing in position and binding all complete above plinth level.	200.000	Kg		0.00	0.00	0.00	INR Zero Only
18.0	<b>Brick Work</b>							

[Validate](#)[Print](#)[Help](#)

## Item Rate BoQ

Tender Inviting Authority: Projects &amp; Development India Limited, Noida

Name of Work: Electrical Works (Supply &amp; Erection) Tender For Alternate Power Supply Arrangement of Vikrampur Guest House At Talcher Fertilizer Complex - Angul

Contract No: PNP/PC 183/E/8001/NCB

**NOTE :** Quantities mentioned in the Schedule of Rates are indicative and not exhaustive in nature. Payment shall be made as per actual quantity used/certified at site by Owner's Engineer-in-charge. Quantities indicated in Schedule of Rates are approximate and subject to variation on either side. The quantity of individual item may be deleted. Contractor shall not be entitled for any compensation on this account and the quoted rates shall hold good for such quantity variations etc. Payments on bills shall, however, be made on actual measurements of quantities of work done as per approved drawings. **Goods & Services Tax (GST) is applicable @ 18% on the quoted rates (being Works Contract).**

Name of the Bidder/ Bidding Firm / Company :	
--	--

**SCHEDULE OF RATES** (This BOQ template must not be modified/replaced by the bidder and the same should be uploaded after filling the relevent columns, else the bidder is liable to be rejected for this tender. Bidders are allowed to enter the Bidder Name and Values only )

NUMBER	TEXT #	NUMBER #	TEXT #	NUMBER #	NUMBER	NUMBER #	NUMBER #	TEXT #
Sl. No.	Item Description	Quantity	Units	BASIC RATE In Figures To be entered by the Bidder in Rs. P	GST @ 18% in RS. P	TOTAL AMOUNT Incl. All taxes & duties (Excl. GST) in Rs. P	TOTAL AMOUNT Incl. All taxes , duties and GST in Rs. P	TOTAL AMOUNT Incl. All taxes, duties and GST In Words
18.01	Providing and constructing Brick work with non modular fly ash bricks conforming to IS:12894, class designation 10 average compressive strength in in cement mortar 1 : 6 ( 1 cement: 6 coarse sand )inwalls, etc. at all depths, places and positions including raking out joints, curing, scaffolding etc. complete excluding plastering and painting.	1.500	CuM		0.00	0.00	0.00	INR Zero Only
18.02	Half brick masonry with common burnt clay F.P.S. (non modular) bricks of class designation 7.5 in foundations and plinth in : Cement mortar 1:4 (1 cement : 4 coarse sand).	1.500	CuM		0.00	0.00	0.00	INR Zero Only
<b>19.0</b>	<b>Finishing</b>							
19.01	12 mm thick cement plaster 1:6 (1 cement: 6 fine sand) after properly cleaning etc. as per instruction of PDIL Engineer.	36.000	SqM		0.00	0.00	0.00	INR Zero Only

[Validate](#)[Print](#)[Help](#)

## Item Rate BoQ

Tender Inviting Authority: Projects &amp; Development India Limited, Noida

Name of Work: Electrical Works (Supply &amp; Erection) Tender For Alternate Power Supply Arrangement of Vikrampur Guest House At Talcher Fertilizer Complex - Angul

Contract No: PNPM/PC 183/E/8001/NCB

**NOTE : Quantities mentioned in the Schedule of Rates are indicative and not exhaustive in nature. Payment shall be made as per actual quantity used/certified at site by Owner's Engineer-in-charge. Quantities indicated in Schedule of Rates are approximate and subject to variation on either side. The quantity of individual item may be deleted. Contractor shall not be entitled for any compensation on this account and the quoted rates shall hold good for such quantity variations etc. Payments on bills shall, however, be made on actual measurements of quantities of work done as per approved drawings. Goods & Services Tax (GST) is applicable @ 18% on the quoted rates (being Works Contract).**

<b>Name of the Bidder/ Bidding Firm / Company :</b>								
<b>SCHEDULE OF RATES</b> (This BOQ template must not be modified/replaced by the bidder and the same should be uploaded after filling the relevent columns, else the bidder is liable to be rejected for this tender. Bidders are allowed to enter the Bidder Name and Values only )								
NUMBER	TEXT #	NUMBER #	TEXT #	NUMBER #	NUMBER	NUMBER #	NUMBER #	TEXT #
Sl. No.	Item Description	Quantity	Units	BASIC RATE In Figures To be entered by the Bidder in Rs. P	GST @ 18% in RS. P	TOTAL AMOUNT Incl. All taxes & duties (Excl. GST) in Rs. P	TOTAL AMOUNT Incl. All taxes , duties and GST in Rs. P	TOTAL AMOUNT Incl. All taxes, duties and GST In Words
19.02	Wall painting with Plastic Emulsion Paint of approved brand and manufacture to give an even shade :New work (two or more coats) over and including water thinnable priming coat with cement primer	36.000	SqM		0.00	0.00	0.00	INR Zero Only
<b>20.0</b>	<b>Fencing &amp; Gate</b> (Made of G.I. wire of dia 4 mm)							
20.01	Providing and fixing G.I. chain link fabric fencing of required width in mesh size 50x50 mm including strengthening with 2 mm dia wire or nuts, bolts and washers as required complete as per the direction of Engineer-in-charge.	20.000	SqM		0.00	0.00	0.00	INR Zero Only

[Validate](#)[Print](#)[Help](#)

## Item Rate BoQ

Tender Inviting Authority: Projects &amp; Development India Limited, Noida

Name of Work: Electrical Works (Supply &amp; Erection) Tender For Alternate Power Supply Arrangement of Vikrampur Guest House At Talcher Fertilizer Complex - Angul

Contract No: PNP/PC 183/E/8001/NCB

**NOTE :** Quantities mentioned in the Schedule of Rates are indicative and not exhaustive in nature. Payment shall be made as per actual quantity used/certified at site by Owner's Engineer-in-charge. Quantities indicated in Schedule of Rates are approximate and subject to variation on either side. The quantity of individual item may be deleted. Contractor shall not be entitled for any compensation on this account and the quoted rates shall hold good for such quantity variations etc. Payments on bills shall, however, be made on actual measurements of quantities of work done as per approved drawings. **Goods & Services Tax (GST) is applicable @ 18% on the quoted rates (being Works Contract).**

Name of the Bidder/ Bidding Firm / Company :	
--	--

**SCHEDULE OF RATES** (This BOQ template must not be modified/replaced by the bidder and the same should be uploaded after filling the relevent columns, else the bidder is liable to be rejected for this tender. Bidders are allowed to enter the Bidder Name and Values only )

NUMBER	TEXT #	NUMBER #	TEXT #	NUMBER #	NUMBER	NUMBER #	NUMBER #	TEXT #
Sl. No.	Item Description	Quantity	Units	BASIC RATE In Figures To be entered by the Bidder in Rs. P	GST @ 18% in RS. P	TOTAL AMOUNT Incl. All taxes & duties (Excl. GST) in Rs. P	TOTAL AMOUNT Incl. All taxes , duties and GST in Rs. P	TOTAL AMOUNT Incl. All taxes, duties and GST In Words
20.02	Providing and fixing concertina coil fencing with punched tape concertina coil 600 mm dia 10 metre openable length ( total length 90 m), having 50 nos rounds per 6 metre length, upto 3 m height of wall with existing angle iron 'Y' shaped placed 2.4m or 3.00 m apart and with 9 horizontal R.B.T. reinforced barbed wire, stud tied with G.I. staples and G.I. clips to retain horizontal, including necessary bolts or G.I. barbed wire tied to angle iron, all complete as per direction of Engineer-in-charge, with reinforced barbed tape (R.B.T.) / Spring core (2.5mm thick) wire of high tensile strength of 165 kg/sq.mm with tape (0.52 mm thick) and weight 43.478 gm/ metre (cost of M.S. angle, C.C. blocks shall be paid separately)	12.000	Run. Mtrs		0.00	0.00	0.00	INR Zero Only
20.03	Providing & Laying of Pebbles (20mm to 50mm) round in shape of good quality, free from organic material sulphates or any deleterious material.	20.000	CuM		0.00	0.00	0.00	INR Zero Only

Validate

Print

Help

### Item Rate BoQ

Tender Inviting Authority: Projects & Development India Limited, Noida

Name of Work: Electrical Works (Supply & Erection) Tender For Alternate Power Supply Arrangement of Vikrampur Guest House At Talcher Fertilizer Complex - Angul

Contract No: PNP/PC 183/E/8001/NCB

**NOTE : Quantities mentioned in the Schedule of Rates are indicative and not exhaustive in nature. Payment shall be made as per actual quantity used/certified at site by Owner's Engineer-in-charge. Quantities indicated in Schedule of Rates are approximate and subject to variation on either side. The quantity of individual item may be deleted. Contractor shall not be entitled for any compensation on this account and the quoted rates shall hold good for such quantity variations etc. Payments on bills shall, however, be made on actual measurements of quantities of work done as per approved drawings. Goods & Services Tax (GST) is applicable @ 18% on the quoted rates (being Works Contract).**

<b>Name of the Bidder/ Bidding Firm / Company :</b>	
---	--

**SCHEDULE OF RATES (This BOQ template must not be modified/replaced by the bidder and the same should be uploaded after filling the relevent columns, else the bidder is liable to be rejected for this tender. Bidders are allowed to enter the Bidder Name and Values only )**

NUMBER	TEXT #	NUMBER #	TEXT #	NUMBER #	NUMBER	NUMBER #	NUMBER #	TEXT #
Sl. No.	Item Description	Quantity	Units	BASIC RATE In Figures To be entered by the Bidder in Rs. P	GST @ 18% in RS. P	TOTAL AMOUNT Incl. All taxes & duties (Excl. GST) in Rs. P	TOTAL AMOUNT Incl. All taxes , duties and GST in Rs. P	TOTAL AMOUNT Incl. All taxes, duties and GST In Words
20.04	Supplying, transporting, de-rusting, fabricating, erecting, hoisting and fixing in position with necessary welding and/or bolting with MS bolts conforming to property class 8.8 of IS: 1367 at all heights as per approved fabrication drawings of all types of structural steel work in columns, portals, girders, lattice girders, beams, crane girders, M.S rails, monorails, bracings, trusses, purlins, rafters, side runners, sag rods, hand railings, staircase stringers and steps, walkway, toe-plates, floor grids, sag rods with M.S. rounds, side walling, conveyor gantries, trestle for pipe and cable racks, gusset plates, etc., either made of rolled steel joists, channels, angles, tees, flats, plates , universal sections or built up from plates and/or rolled steel sections including necessary site and shop fasteners, complete in all respects as per approved fabrication drawings, standards and direction of Engineer-in-Charge . <b>With providing and applying primer coat, intermediate coats and finish coat after the preparation of surfaces on structural steel work complete in all respects as per technical specifications and direction of Engineer-in-Charge.</b>	0.200	Ton		0.00	0.00	0.00	INR Zero Only

Validate

Print

Help

### Item Rate BoQ

Tender Inviting Authority: Projects & Development India Limited, Noida

Name of Work: Electrical Works (Supply & Erection) Tender For Alternate Power Supply Arrangement of Vikrampur Guest House At Talcher Fertilizer Complex - Angul

Contract No: PNP/PC 183/E/8001/NCB

**NOTE :** Quantities mentioned in the Schedule of Rates are indicative and not exhaustive in nature. Payment shall be made as per actual quantity used/certified at site by Owner's Engineer-in-charge. Quantities indicated in Schedule of Rates are approximate and subject to variation on either side. The quantity of individual item may be deleted. Contractor shall not be entitled for any compensation on this account and the quoted rates shall hold good for such quantity variations etc. Payments on bills shall, however, be made on actual measurements of quantities of work done as per approved drawings. **Goods & Services Tax (GST) is applicable @ 18% on the quoted rates (being Works Contract).**

<b>Name of the Bidder/ Bidding Firm / Company :</b>	
---	--

**SCHEDULE OF RATES** (This BOQ template must not be modified/replaced by the bidder and the same should be uploaded after filling the relevent columns, else the bidder is liable to be rejected for this tender. Bidders are allowed to enter the Bidder Name and Values only )

NUMBER	TEXT #	NUMBER #	TEXT #	NUMBER #	NUMBER	NUMBER #	NUMBER #	TEXT #
Sl. No.	Item Description	Quantity	Units	BASIC RATE In Figures To be entered by the Bidder in Rs. P	GST @ 18% in RS. P	TOTAL AMOUNT Incl. All taxes & duties (Excl. GST) in Rs. P	TOTAL AMOUNT Incl. All taxes , duties and GST in Rs. P	TOTAL AMOUNT Incl. All taxes, duties and GST In Words
<b>Total in Figures</b>						<b>0.00</b>	<b>0.00</b>	INR Zero Only
<b>Quoted Rate in Words</b>				<b>INR Zero Only</b>				